

ZSR 5/11 - 5 KE

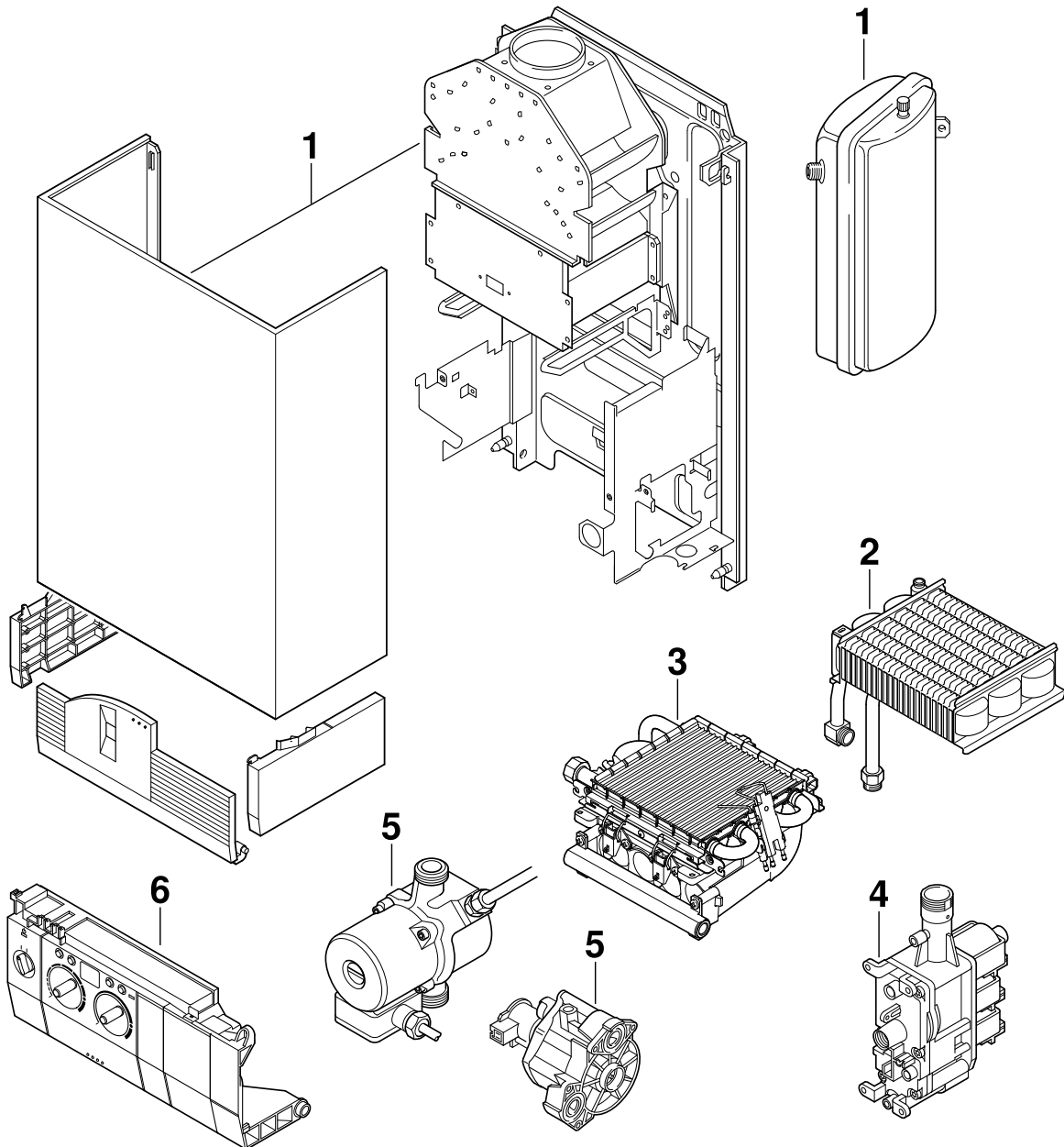

6720901494/G

[de] Wichtige Hinweise zur Installation/Montage

Die Installation/Montage muss durch eine für die Arbeiten zugelassene Fachkraft unter Beachtung der geltenden Vorschriften erfolgen.

[en] Important notes on installation/assembly

The installation/assembly must be carried out by a qualified contractor, following these instructions and in compliance with the applicable regulations.

[fr] Instructions importantes pour l'installation/le montage

L'installation/le montage doit être effectué(e) par un spécialiste qualifié pour les opérations concernées et dans le respect de la présente notice et des prescriptions applicables.

[bg] Важни указания във връзка с инсталацията/монтажа

Инсталацията/монтажът трябва да се извършва от лицензиран за работите специалист в съответствие с настоящото ръководство и с приложимите разпоредби.

[cs] Důležité pokyny k instalaci/montáži

Instalaci/montáž musí při dodržení pokynů uvedených v tomto návodu a platných předpisů provést odborný pracovník s příslušným oprávněním pro tyto práce.

[da] Vigtige anvisninger til installationen/monteringen

Installationen/monteringen skal foretages af en godkendt installatør under overholdelse af denne vejledning og de gældende forskrifter.

[el] Σημαντικές υποδείξεις για την εγκατάσταση/συναρμολόγηση

Η εγκατάσταση/τοποθέτηση πρέπει να ανατίθεται σε εκπαιδευμένο για τις συγκεκριμένες εργασίες τεχνικό προσωπικό με τήρηση αυτών των οδηγιών καθώς και των σχετικών προδιαγραφών.

[es] Indicaciones importantes para instalación/montaje

La instalación/el montaje debe realizarla personal especializado que esté autorizado para realizar estos trabajos y que tenga en cuenta estas instrucciones y la normativa vigente.

[et] Olulised juhised paigaldamiseks/montaažiks

Paigaldamist/montaaži tohib läbi viia vaid selleks volitusi omav spetsialist, arvestades kehtivaid nõudeid.

[nl-BE] Belangrijke aanwijzingen betreffende de installatie/montage

De installatie/montage moet worden uitgevoerd door een voor de werkzaamheden geautoriseerde installateur rekening houdend met deze handleiding en de geldende voorschriften.

[fi] Tärkeitä asennus- ja kokoonpano-ohjeita

Näihin töihin hyväksytyn ammattiasentajan pitää suorittaa asennus- ja kokoonpanotyöt voimassa olevien määräysten mukaisesti.

[hu] Fontos tudnivalók az installáláshoz/szereléshez

A telepítést/szerelést egy, a munkálatokra felhatalmazott szakembernek kell végeznie, jelen utasítás és az érvényes előírások figyelembevételével.

[it] Avvertenze importanti per l'installazione/il montaggio

L'installazione/il montaggio deve aver luogo ad opera di una ditta specializzata ed autorizzata in osservanza di queste istruzioni e delle direttive vigenti.

[ka] მნიშვნელოვანი მითითებები ინსტალაციისთვის/მონტაჟისთვის

ინსტალაცია/მონტაჟი უნდა განხორციელდეს სამუშაოებისთვის დაშვებული კვალიფიციური პერსონალის მიერ, მოქმედი განაწესის დაცვით.

[lt] Svarbios instaliavimo ir (arba) montavimo nuorodos

Instaliavimo / montavimo darbus, laikydamiės šios instrukcijos reikalavimų ir galiojančių taisyklių, privalo atlikti šioms darbams įgalioti specialistai.

[lv] Svarīgi norādījumi par iekārtas uzstādīšanu / montāžu

Uzstādīšanu/montāžu jāveic atbilstošajiem darbiem sertificētam speciālistam, ievērojot šo instrukciju un spēkā esošos noteikumus.

[nl] Belangrijke aanwijzingen betreffende de installatie/montage

De installatie/montage moet door een erkend installateur volgens de geldende voorschriften worden uitgevoerd.

[no] Viktig informasjon om installasjon/montering

Installasjonen/monteringen skal gjennomføres av autoriserte installatører, og installasjonsanvisningen samt gjeldende forskrifter skal følges.

[pl] Ważne wskazówki dotyczące instalacji/montażu

Instalację/montaż powinien wykonać specjalista uprawniony do tego typu prac z uwzględnieniem informacji podanych w niniejszej instrukcji oraz aktualnie obowiązujących przepisów.

[pt] Indicações importantes relativas à instalação/montagem

A instalação/montagem deve ser efectuada por um técnico autorizado para os trabalhos, respeitando este manual e as prescrições válidas.

[ro] Indicații importante privind instalarea/montajul

Instalarea/montajul trebuie realizate de către un specialist autorizat pentru lucrările respective, respectându-se prezentele instrucțiuni și prescripțiile valabile.

[ru] Важные указания по подключению/монтажу

Подключение/монтаж должны выполнять только специалисты, имеющие допуск к выполнению таких работ, при соблюдении требований этой инструкции и действующих норм и правил.

[sk] Dôležité pokyny týkajúce sa inštalácie/montáže

Inštaláciu/montáž musí vykonať odborný personál, ktorý má oprávnenie pre výkon týchto prác, pričom musí dodržiavať pokyny uvedené v tomto návode a platné predpisy.

[sl] Pomembni napotki za namestitvev/montažo

Inštalacija/montažo lahko izvede samo pooblaščen strokovnjak ob upoštevanju teh navodil in veljavnih predpisov.

[sr] Važna uputstva za ugradnju i montažu

Ovu instalaciju/montažu moraju da obave stručna lica koja su ovlašćena za obavljanje takvih radova u skladu sa ovim uputstvom i važećim propisima.

[sv] Viktiga anvisningar för installation/montering

Installationen/monteringen måste utföras av en behörig och tekniskt utbildad person enligt denna anvisning samt gällande föreskrifter.

[tr] Kurulum/Montaj ile ilgili önemli uyarılar

Kurulum/montaj, bu çalışmalarını yapmasına müsaade edilen uzman kişiler tarafından işbu kılavuz ve geçerli yönetmelikler dikkate alınarak yapılmalıdır.

[uk] Важливі вказівки щодо установки/монтажу

Встановлення/монтаж повинні виконувати фахівці, що допущені до виконання таких робіт, із дотриманням цієї інструкції та діючих приписів.

[zh] 安装方面的重要提示

安装和组装工作必须由经过许可的专业人员进行，同时必须遵守本说明书和现行法规的相关要求

[ar] ملاحظات هامة للتركيب/التجميع

يجب أن يتم التركيب/التجميع من قبل متخصص مصرح له بالعمل، مع مراعاة اللوائح السارية.

[fa] تذکرات مهم درباره نصب/مونتاژ

نصب/مونتاژ باید توسط فردی حرفه ای که مجاز به انجام این کار است، و همچنین با توجه کامل به مقررات مربوطه انجام شود.

Ersatzteilliste
Spare parts list

Liste des pièces de rechange
Lista parti di ricambio

Lista de repuestos
Onderdelenlijst

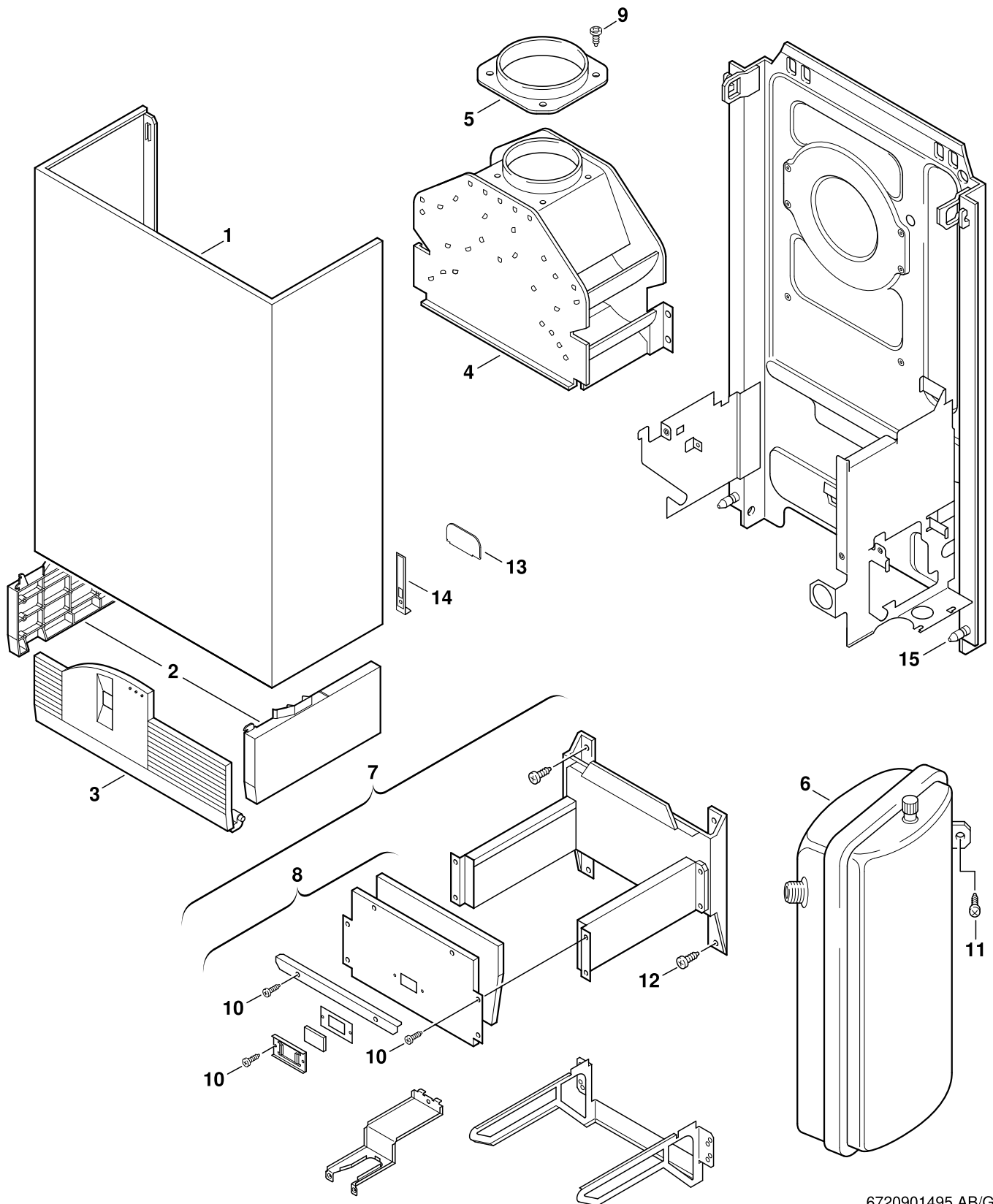

6720901495.AB/G

1

Blechteile
Sheet metal
Pièces de tôle
Parti di lamiera
Piezas de chapa
Mantel

ZSR 5/11 - 5 KE

Pos	Bezeichnung Description Dénomination Descrizioni Descripción Benaming	Bestell-Nr. Ordering no. Numéro de commande N° d'ordine Número el ordenar Bestellnummer	ZSR5/11-5																			Bemerkungen Remarks Remarques Osservazioni Observaciones Opmerkingen
1	Mantel	8 715 401 312 0	■																			
2	Seitenblendensatz	8 715 506 331 0	■																			
3	Klappe	8 715 506 321 0	■																			
4	Strömungssicherung	8 715 505 609 0	■																			
5	Anschlusselement Abgasstutzen	8 705 504 143 0	■																			
6	Ausdehnungsgefäß 7,5l	8 715 407 140 0	■																			
7	Brennkammer	8 715 406 401 0	■																			
8	Vorderwand	8 715 402 329 0	■																			
9	Schraube DIN7981 3,9x9,5 (10x)	2 918 140 417 0	■																			
10	Schraube DIN7981 4,2x9,5 (10x)	2 910 612 424 0	■																			
11	Schraube 4,8x9,5 (10x)	2 910 614 431 0	■																			
12	Schraube (10x)	2 910 612 427 0	■																			
13	Isolierplatte	8 711 003 056 0	■																			
14	Einrasthebel	8 715 503 115 0	■																			
15	Verschlussatz	8 713 101 060 0	■																			

ZSR 5/11 - 5 KE		Blechteile Sheet metal Pièces de tôle Parti di lamiera Piezas de chapa Mantel	1
------------------------	--	--	----------

Ersatzteilliste
Spare parts list

Liste des pièces de rechange
Lista parti di ricambio

Lista de repuestos
Onderdelenlijst

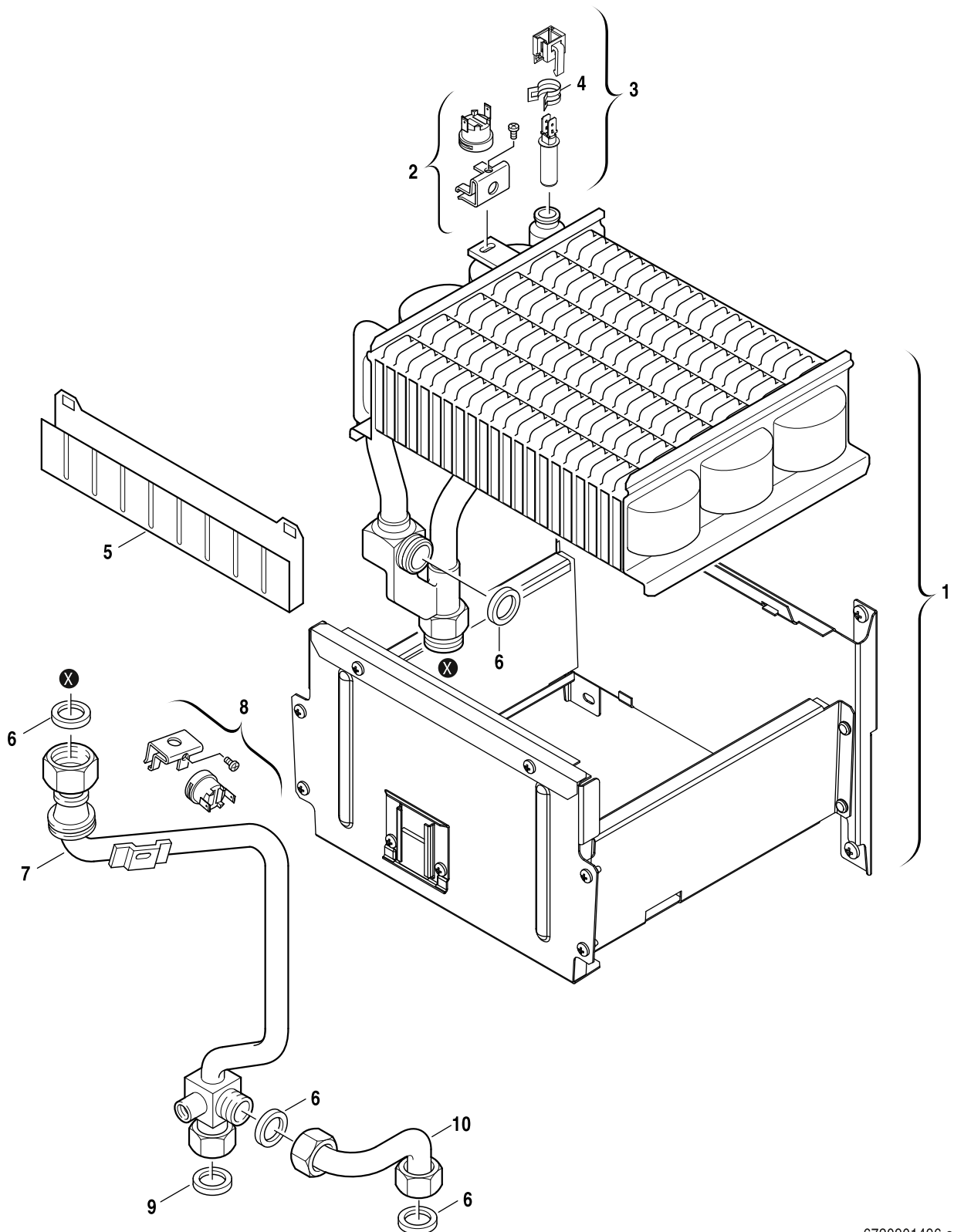

6720901496.ab.RO

2

Wärmeübertrager
Heat exchanger
Caloporteur
Blocco lamellare
Cambiador de calor
Warmtewisselaar

ZSR 5/11 - 5 KE

Pos	Bezeichnung Description Dénomination Descrizioni Descripción Benaming	Bestell-Nr. Ordering no. Numéro de commande N° d'ordine Número el ordenar Bestellnummer	ZSR5/11-5																					Bemerkungen Remarks Remarques Osservazioni Observaciones Opmerkingen
1	Wärmetauscher	8 715 406 405 0	■																					
2	Temperaturbegrenzer 120°C	8 717 206 164 0	■																					
3	Temperaturfühler	8 714 500 071 0	■																					
4	Feder (10x)	8 711 202 002 0	■																					
5	Abgastemperaturblende	8 718 003 730 0	■																					
6	Dichtung 18.6x13.5x1.5 (10x)	8 710 103 045 0	■																					
7	Vorlaufrohr	8 710 715 481 0	■																					
8	Temperaturbegrenzer 110°C	8 717 206 162 0	■																					
9	Dichtung 23.9x17.2x1.5 (10x)	8 710 103 043 0	■																					
10	Verbindungsrohr	8 710 705 980 0	■																					



ZSR 5/11 - 5 KE	Wärmeübertrager Heat exchanger Caloporteur Blocco lamellare Cambiador de calor Warmtewisselaar	2
------------------------	---	----------

Ersatzteilliste
Spare parts list

Liste des pièces de rechange
Lista parti di ricambio

Lista de repuestos
Onderdelenlijst

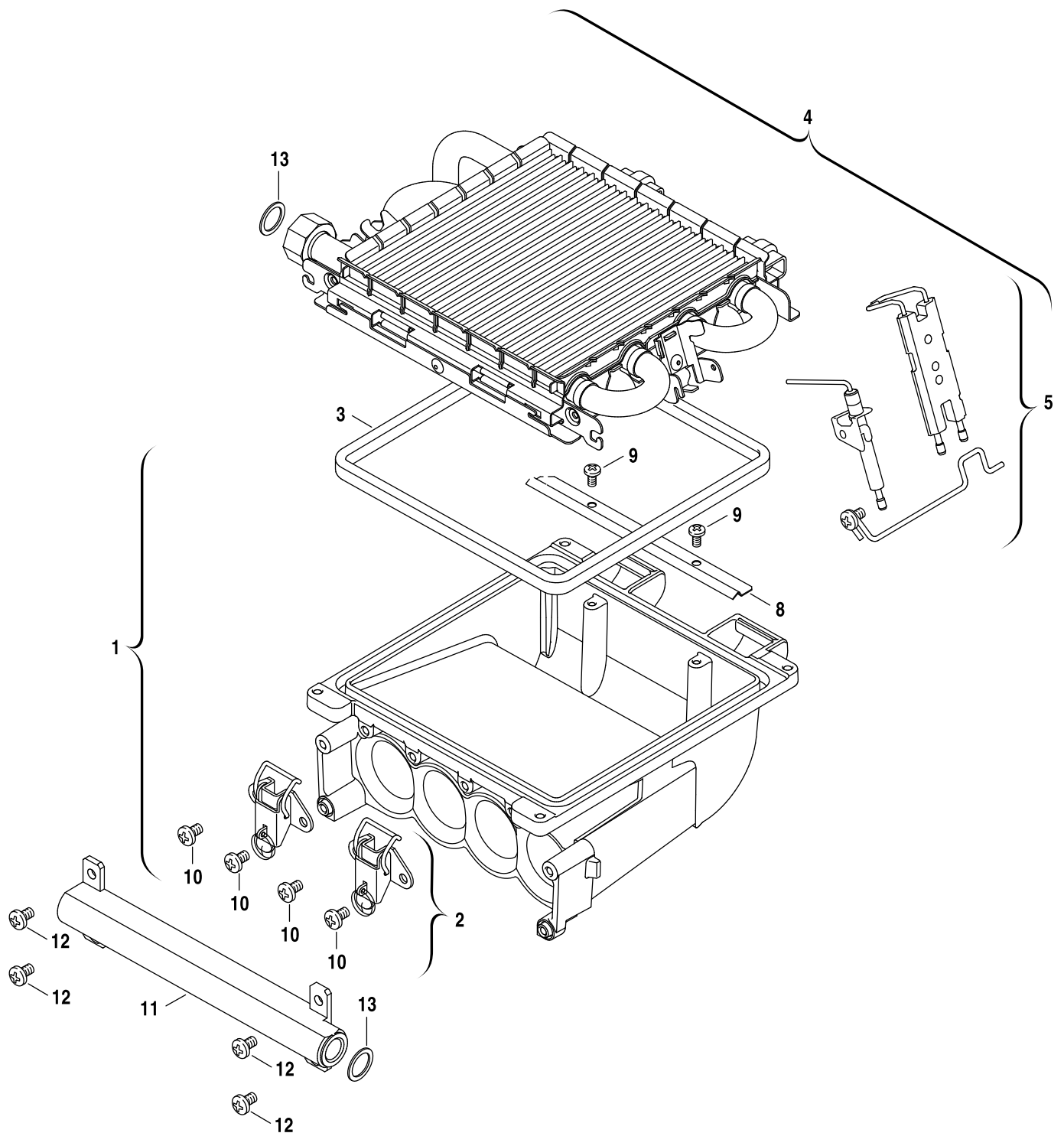

6720906171.ab.RO

3

Brenner
Burner
Brûleur
Bruciatore
Quemador
Brander

ZSR 5/11 - 5 KE

Ersatzteilliste
Spare parts list

Liste des pièces de rechange
Lista parti di ricambio

Lista de repuestos
Onderdelenlijst

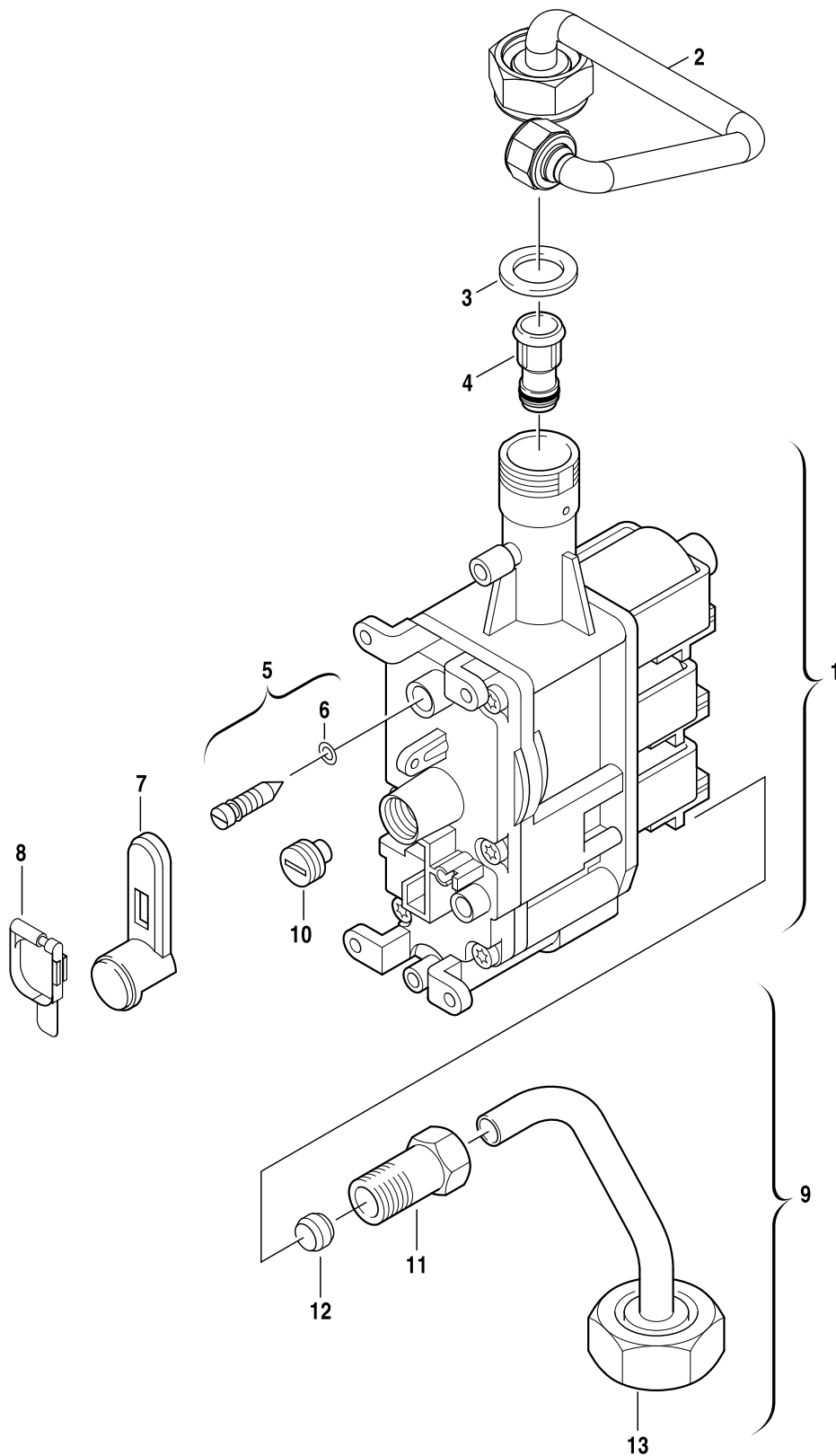

6720901498.ab.G

4

Gasarmatur
Gas valve
Bloc gaz
Gruppo gas
Cuerpo de gas
Gasregelblok

ZSR 5/11 - 5 KE

Ersatzteilliste
Spare parts list

Liste des pièces de rechange
Lista parti di ricambio

Lista de repuestos
Onderdelenlijst

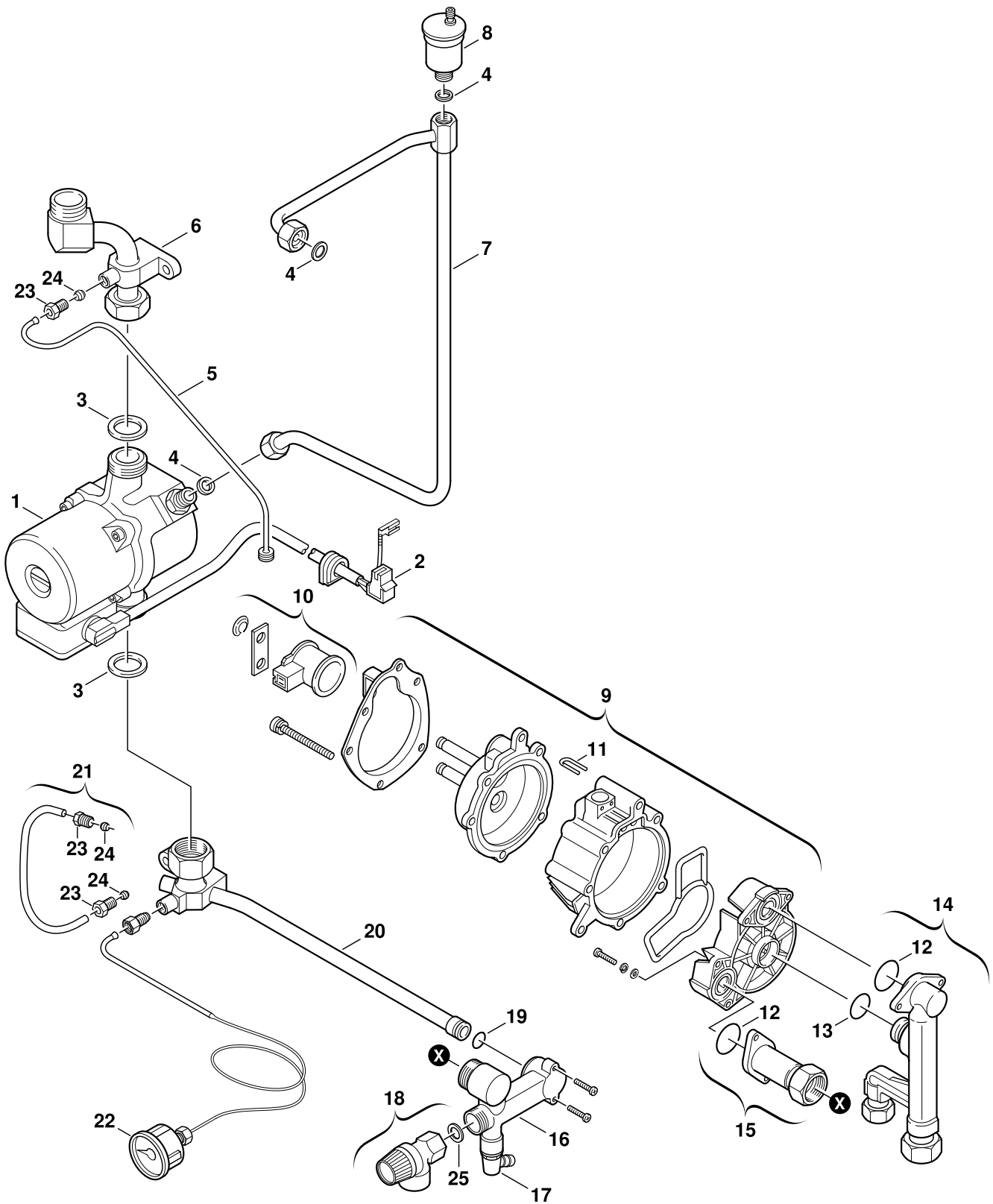

6720901499/G

5

Pumpe/Hydraulikschalter
Pump/Hydraulic valve
Pompe/Vanne 3 voies
Pompa/Valvola deviatrice
Bomba/Interruptor hidráulico
Pomp/Circuit klep

ZSR 5/11 - 5 KE

Ersatzteilliste
Spare parts list

Liste des pièces de rechange
Lista parti di ricambio

Lista de repuestos
Onderdelenlijst

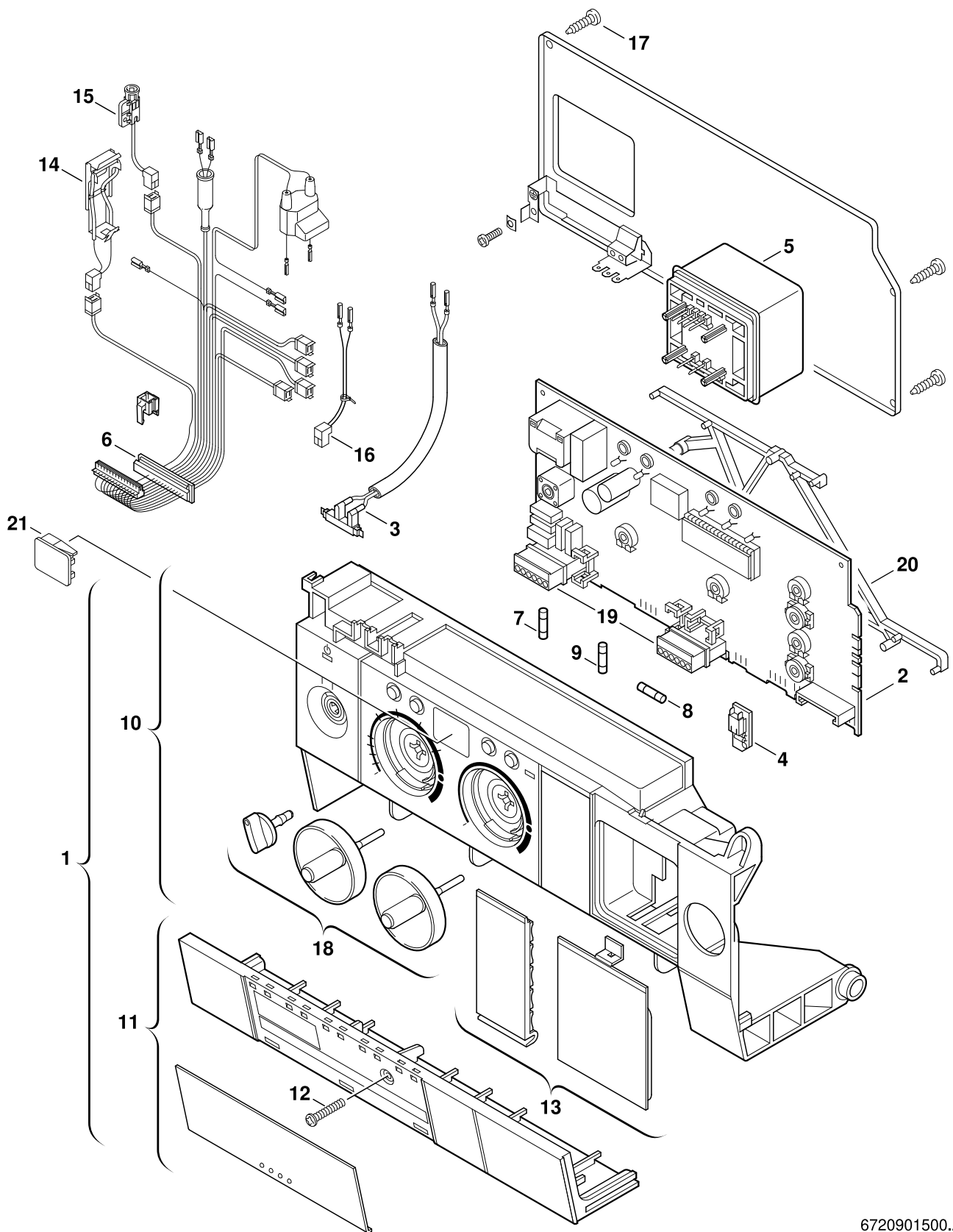

6720901500.AB/G

6 Schaltkasten
Control box
Tableau de commande
Quadro comandi
Caja de conexiones
Schakelkast

ZSR 5/11 - 5 KE

Übersetzungsliste		Liste des traductions		Lista de traducciones	
List of translations		Traduzione delle descrizioni		Vertalinglijst	
Pos	Description	Denomination	Descrizione	Descripción	Benaming
1	Element of construction	Groupe de construction	Gruppo di costruzione	Grupo de construccion	Montagegroep
1	Front shell	Habillage	Mantello	Carcasa	Mantel
2	Sideshield set	Sachet de façade	Set penelli laterali	Conjunto chapa cuadro	Zij paneelset
3	Cover	Couvercle	Sportello	Tapa	Deksel
4	Draught diverter	Coupe tirage antirefouleur	Disp. Controllo corrento	Seguro evacuación de gases	TREKONDERBREKER MINI 11 K (EX8715505609)
5	Exhaust pipe union	Colerette de buse	Terminale condotto	Acoplamiento salida gas	Rookgasafvoerstuts
6	Expansion vessel 7,5l	Vase d'expansion 7,5l	Vaso di espansione 7,5l	Vaso de expansión 7,5l	Expansievat 7,5l
7	Combustion chamber	Chambre de combustion	Camera combustione	Cámara de quemadores	Verbrandingskamer
8	Kryt kotle pædnl	Couvercle	Coperchio	Tapa	Voordeksel
9	Screw DIN7981 3,9x9,5 (10x)	Vis DIN7981 3,9x9,5 (10x)	Vite DIN7981 3,9x9,5 (10x)	Tornillo (10x)	Schroef DIN7981 3,9x9,5 (10x)
10	Screw DIN7981 4,2x9,5 (10x)	Vis 4,2x9,5 (10x)	Vite 4,2x9,5 (10x)	Tornillo (10x)	Schroef 4,2x9,5 (10x)
11	Screw 4,8x9,5 (10x)	Vis 4,8x9,5 (10x)	Vite 4,8x9,5 (10x)	Tornillo 4,8x9,5 (10x)	Schroef 4,8x9,5 (10x)
12	Screw (10x)	Vis (10x)	Vite (10x)	Tornillo (10x)	Schroef (10x)
13	Insulation plate	Plaque d'isolation	Piastra isolante	Placa aislante	Isolatie plaat
14	Mounting holder	Manette de blocage	Bussola	Fijación de soporte	Een greeps hendel
15	Lock set	Sachet de serrure	Coperchio	Conjunto cerradura	Afsluitingsset
2	Element of construction	Groupe de construction	Gruppo di costruzione	Grupo de construccion	Montagegroep
1	Heat exchanger	Echangeur thermique	Scambiatore di calore	Cambiafor de calor	Tapboiler
2	Temperature limit 120°C	Limiteur de température 120°C	Limitatore temperatura 120°C	Limitador de temperatura 120°C	Temperatuurbegrenzer 120°C
3	Temperature sensor	Sonde de temperature	Sensore termometrico	Sensor de temperatura	Temperatuurvoeler
4	Clamping spring (10x)	Ressort (10x)	Molla (10x)	Clip de fijación (10x)	Klemveer (10x)
5	Deflector	Défecteur	Staffa	Deflector	Rookgasafvoertemp. Afschermplaat
6	Washer 18.6x13.5x1.5 (10x)	Joint 18.6x13.5x1.5 (10x)	Guarnizione 18.6x13.5x1.5 (10x)	Junta 1/2" (10x)	Afdichtring 18.6x13.5x1.5 (10x)
7	Flow pipe	Tube départ chauffage	Raccordo	Tubo de salida	BUIS AANVOER WARMTEWISSELAAR ZR 11-3AE/3
8	Temperature limit 110°C	Limiteur de température 110°C	Limitatore temperatura 110°C	Limitador de temperatura 110°C	Temperatuurbegrenzer 110°C
9	Washer 23.9x17.2x1.5 (10x)	Joint 23.9x17.2x1.5 (10x)	Guarnizione 23.9x17.2x1.5 (10x)	Junta 3/4" (5x)	Afdichtring 23.9x17.2x1.5 (10x)
10	Connecting pipe	Tube de raccordement	Raccordo	Tubo agua	Verbindingspijp
3	Element of construction	Groupe de construction	Gruppo di costruzione	Grupo de construccion	Montagegroep
1	Burner body 11kW	Corps de br#leur 11kW	Bruciatore 11kW	Cuerpo de quemador 11kW	Bescherm brander 11kW
2	Lock	Serrure	Chiusura	Cerradura	bevestigingsklemmen
3	Burner sealing 11kW	Joint de br#leur 11kW	Guarnizione bruciatore 11kW	Junta de quemador 11kW	Brander afdichting 11kW

Übersetzungsliste List of translations		Liste des traductions Traduzione delle descrizioni		Lista de traducciones Vertalinglijst	
Pos	Description	Denomination	Descrizione	Descripción	Benaming
4	Burner head 11kW	T#te de br#leur 11kW	Coperchio bruciatore 11kW	Tapa de quemador 11kW	Brander dek 11kW
5	Set of electrodes	Jeu d'électrodes	Set di elettrodi	Conjunto electrodo	Elektrodenstet
8	Covering sheet 11kW	Tôle de protection 11kW	Deflettore 11kW	Encimera 11kW	Afschermplaat 11kW
9	Screw M4 x 8 Hex Hd Pozi Taptite	Screw M4 x 8 Hex Hd Pozi Taptite	Screw M4 x 8 Hex Hd Pozi Taptite	tornillo M4 x 8 Hex Hd Pozi Taptite	Screw M4 x 8 Hex Hd Pozi Taptite
10	Screw M5x8	Vis M5x8	Vite M5x8	Tornillo M5x8	Schroef M5x8
11	Gas conversion set	Kit de transformation de gaz	Kit conversione gas	Kit de conversión de gas	Gasombouwset
11	Gas conversion set 23,31>21	Kit de transformation de gaz 23,31>21	Kit conversione gas 23,31>21	Kit de conversión de gas 23,31>21	Gasombouwset 23,31>21
11	Gas conversion set 21,31>23	Kit de transformation de gaz 21,31>23	Kit conversione gas 21,31>23	Kit de conversión de gas 21,31>23	Gasombouwset 21,31>23
11	Gas conversion set 21,23>31	Kit de transformation de gaz 21,23>31	Kit conversione gas 21,23>31	Kit de conversión de gas 21,23>31	Gasombouwset 21,23>31
11	Gas conver. set without code plug 21>23	Kit de transformation without code plug	Kit conversione gas 21>23	Kit de conversión de gas 21>23	Gasombouwset 21>23
12	Screw M5x12 (10x)	Vis M5x12 (10x)	Vite M5x12 (10x)	Tornillo M5x12 (10x)	Schroef M5x12 (10x)
13	Washer 18.6x13.5x1.5 (10x)	Joint 18.6x13.5x1.5 (10x)	Guarnizione 18.6x13.5x1.5 (10x)	Junta 1/2" (10x)	Afdichtring 18.6x13.5x1.5 (10x)
	Service Kit 11 kW	Service Kit 11 kW	Service Kit 11 kW	Service Kit 11 kW	Service Kit 11 kW
	Grease HFT1V5	Graisse HFT1V5	Grasso HFT1V5	Grasa HFT1V5	Gas-watervet HFT1V5 50 gr.
4	Element of construction	Groupe de construction	Gruppo di costruzione	Grupo de construccion	Montagegroep
1	Gas valve	Bloc Gaz	Gruppo Gas	Cuerpo de Gas	Gasregelblok
2	Gas pipe	Tube gaz	Tubo gas	Tubo de gas	Gaspijp
3	Washer 1" (10x)	Joint 1" (10x)	Guarnizione 1" (10x)	Junta 1" (10x)	Pakking (10 x)
4	Throttle bush	Coussinet limiteur	Buccola di strozzaggio	Limitador de flujo	Regelventiel
5	Setting Screw	Vis de réglage (-)	Vite regolazione minimo (-)	Tornillo de ajuste (-)	Intelschroef (-)
5	Setting screw (1.5)	Vis de réglage (1.5)	Vite regolazione minimo (1.5)	Tornillo de ajuste (1.5)	INTELSCHROEF 1,5 CERAMINI "31"
6	O-ring	O-ring (10x)	Anello tenuta (10x)	Anillo tórico (10x)	O-ring (10x)
7	Covering sheet	Couvercle (10x)	Coperchio (10x)	Chapa de protección (10x)	Afdichting (10x)
8	Lead seal	Plomb	Piombino (10x)	Plomo precinto (10x)	Loodje (10x)
9	Gas supply pipe	Tube arrivée gaz	Tubo gas	Tubo de entrada de gas	BUIS GASTOEVOER ZR 11-3AE/3KE
10	Sealing screw	Vis de fermeture (10x)	Vite di chiusura (10x)	Tornilla de cierre (10x)	Afdekschroef (10x)
11	Threaded bushing	Douille fileté	Boccola filettata	Casquillo roscado	Draadbus
12	Olive (10x)	Bicône (10x)	Anello (10x)	Anillo bicono (10x)	Klemring (10x)
13	Unit union 1	Ecrou 1"	Dado 1"	Tuerca 1"	Wartelmoer 1"
5	Element of construction	Groupe de construction	Gruppo di costruzione	Grupo de construccion	Montagegroep
1	Pump UPS 15-35-50 160mm G1 230V 50Hz	Circul. UPS 15-35-50 160mm G1 230V 50Hz	Pompa UPS 15-35-50 160mm G1 230V 50Hz	Bomba 3,5 - 5m WS	Pomp UPS 15-35-50 160mm G1 230V 50Hz
2	Cable	Faisceau circulateur	Cabliaggio de pompa	Cable de bomba	Pompkabel

Übersetzungsliste List of translations		Liste des traductions Traduzione delle descrizioni		Lista de traducciones Vertalinglijst	
Pos	Description	Denomination	Descrizione	Descripción	Benaming
3	Washer 1" (10x)	Joint 1" (10x)	Guarnizione 1" (10x)	Junta 1" (10x)	Afdichting 1" (10x)
4	Washer 18.6x13.5x1.5 (10x)	Joint 18.6x13.5x1.5 (10x)	Guarnizione 18.6x13.5x1.5 (10x)	Junta 1/2" (10x)	Afdichtring 18.6x13.5x1.5 (10x)
5	Control pipe	Circuit de commande	Raccordo di comando	Conducto de control	Stuurleiding
6	Return pipe	Tube retour chauffage	Tubazione di ritorno	Tubo de retorno	Retourleiding
7	Venting pipe	Tube de dégazage	Separatore	Conducto de purga	BUIS TSS POMP EN ONTLUCHTER MINI 11 K
8	Automatic purger	Purgeur	Valvola sfiato aria	Purgador	Vlotterontluchter
9	Hydraulic valve	Vanne 3 voies	Valvola deviatrice	Interruptor hidráulico	Circuit klep
10	Solenoid	Electro-vanne	Bobina	Bobina	Spoel
11	Wireform spring	Epingle (10x)	Molla (10x)	Clip de fijacion (10x)	Borgveer (10x)
12	O-ring (10x)	O-ring (10x)	Anello tenuta (10x)	Anillo tórico (10x)	O-ring (10x)
13	O-ring	Joint torique (10x)	Anello tenuta (10x)	Anillo tórico (10x)	O-ring (10x)
14	Valve take up	Support vanne	Raccordo	Tubo de conexión a válvula de tres vías	Ventiel
15	Pipe fitting	Douille	Tubo	Tubuladura	Pijp stuts
16	Return pipe distribution	Tube retour distribution	Raccordo distributore	Tubo retorno distribución	KORTSLUITLEIDING TSS RETOURLEIDING POMP
17	Drain valve	Robinet de vidange	Rubinetto di scarico	grifo de vaciado	Aftapkraan
18	Safety relief valve 3bar	Soupape de sécurité 3bar	Valvola sicurezza 3bar	Válvula de sobrepresión 3bar	Veiligheidsklep 3bar
19	O-ring (10x)	O-ring (10x)	Anello tenuta (10x)	Anillo tórico (10x)	O-ring (10x)
20	Return pipe	Tube retour chauffage	Tubazione di ritorno	Tubo de retorno	BUIS RETOUR POMP ZR 11-3AE/3KE
21	Connecting pipe	Tube By-pass	Raccordo by pass	Tubo agua	Bypas leiding
22	Manometer	Manom#tre	Manometro	Manómetro	Manometer
23	Threaded bushing (10x)	Douille fileté (10x)	Boccola filettata (10x)	Casquillo roscado (10x)	Draadbus (10x)
24	Olive (10x)	Bicône (10x)	Anello (10x)	Anillo bicono (10x)	Klemring (10x)
25	Washer (10x)	Joint (10x)	Guarnizione (10x)	Junta (10x)	Afdichting (10x)
	Grease Unisilkon L641	Graisse Unisilkon L641	Grasso per O-Ring	Grasa Unisilkon L641	Vet Unisilkon L641
	Set of O-rings	Joint torique	Set di anello tenuta	Conjunto de anillo tórico	O-ring
	Set of washers	Sachet de joints	Set di guarnizioni	Conjunto de juntas	Set pakkingen
	Set of washers compact hydraulic	Sachet de joints	Set di guarnizioni	Conjunto de juntas	Set pakkingen
6	Element of construction	Groupe de construction	Gruppo di costruzione	Grupo de construccion	Montagegroep
1	Control unit	Tableau electique	Cassetta ionizzazione	Aparato de mando	Besturingsautomaat
2	Printed circuit	Circuit imprimé	Scheda elettronica	Placa de circuito impreso	Print
3	Ignition lead	Faisceau d'electrodes	Cavetto accensione	Conductor de alta tensión	Hoogspanningsleiding
4	Code plug (227)	Cl de codage (227)	Spina codifica (227)	Conector codificador (227)	Codeer stekker (227)

Übersetzungsliste List of translations		Liste des traductions Traduzione delle descrizioni		Lista de traducciones Vertalinglijst	
Pos	Description	Denomination	Descrizione	Descripción	Benaming
4	Code plug (231)	Cl de codage (231)	Spina codifica (231)	Conector codificador (231)	Codeer stekker (231)
5	Transformer	Transformateur	Trasformatore primario	Transformadores	Transformator
6	Set of cables	Faisceau	Cablaggio	Conjunto cables	Kabel set
7	Fusing element T0,5A (10x)	Fusible T0,5A (x10)	Fusibile T0,5A (10x)	Fusible T0,5A (10x)	Zekering T0,5A (10x)
8	Fusing element T1,6A (10x)	Fusible T1,6A (x10)	Fusibile T1,6A (10x)	Fusible T1,6A (10x)	Zekering T1,6A (10x)
9	Fusing element T2,5A (10x)	Fusible T2,5A (x10)	Fusibile T2,5A (10x)	Fusible T2,5A (10x)	Zekering T2,5A (10x)
10	Casing	Carter	Involucro	Protector	SCHAKELKAST ZWE 24-3MFK (NAAKT)
11	Covering sheet	Couvercle	Coperchio	Chapa de protección	Afdichting
12	Screw	Vis (10x)	Vite (10x)	Tornillo (10x)	Schroef (10x)
13	Shield	Cache	Mascherina	Chapa cuadro	Paneel
14	Flue gas safety device	Spott	Sensore fumi	Dispositivo de control del tiro	Terugslag beveiliging
15	Flue gas safety device	Contrôle d'évacuation des gaz br#lés	Sensore fumi	Dispositivo de control del tiro	Terugslag beveiliging
16	Cable	Câble	Cablaggio di adattamento	Conjunto cables	Kabelgroep
17	Screw 4x15 (10x)	Vis 4x15 (10x)	Vite 4x15 (10x)	Tornillo 4x15 (10x)	Schroef 4x15 (10x)
18	Rotary handles	Croisillon	Manopola	Grifo de girar	Schakelknop
19	Set of plugs	Plots connexion	Morsetto	Conjunto de anection	Stekker set
20	Spacer	Entretoise (10x)	Distanziale (10x)	Collar distanciador (10x)	Afstandhouder (10x)
21	Observation window	Hublot	Vetrinoo	Cristal de observación	Kijkglas
	Set of washers	Sachet de joints	Set di guarnizioni	Conjunto de juntas	Set af dichting
	Servicesortiment Z.R.. -5	Servicesortiment Z.R.. -5	Servicesortiment Z.R.. -5	Servicesortiment Z.R.. -5	Servicesortiment Z.R.. -5
	Fusing element set T0,5/t1,6/t2,5/t3,15A	Sachet fusibles T0,5/T1,6/T2,5/T3,15A	Set di fusibili T0,5/T1,6/T2,5/T3,15A	Conjunto de fusibleT0,5/T1,6/T2,5/T3,15A	Zekeringset T0,5/T1,6/T2,5/T3,15A

Gerätetypen Types of appliances	Types de chaudières Tipo apparecchi	Tipos de aplicaciones Toesteltypes	Bemerkungen Remarks Remarques Osservazioni Observaciones Opmerkingen
Gerät Appliance Chaudière Apparecchio Aparato Toestel	Bestell-Nr. Ordering no. Numéro de commande N° d'ordine Número el ordenar Bestelnummer	Land Country Pays Paese Paese Land	
ZSR5/11-5KE21S0092	7 712 023 885	Deutschland	
ZSR5/11-5KE23S0092	7 712 030 859	Deutschland,Kroatien,Serbien,Slowakei,Ts	
ZSR5/11-5KE31S0092	7 712 043 889	Deutschland,Tschechien,Österreich	
ZSR5/11-5KE23S1492	7 712 030 858	Österreich	



Bosch Thermotechnik GmbH
Junkersstr. 20-24
D-73249 Wernau / Germany