

H65W, WU120W - WU160W

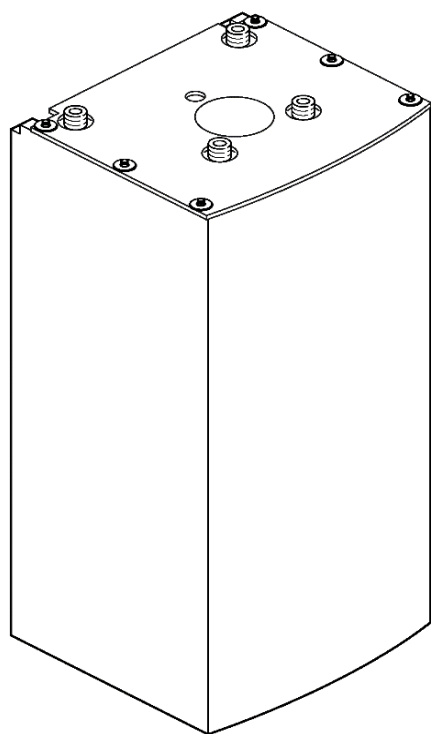

H65W

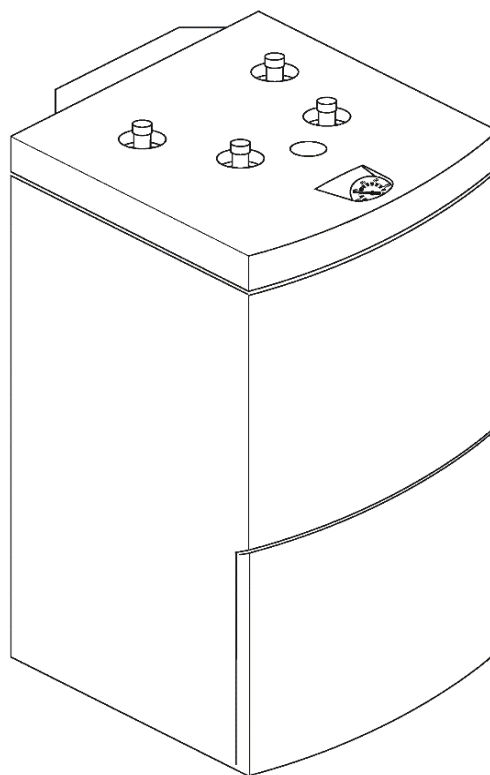

WU120-160W

6720906844.aa.RS-H65, WU120W-160W

Buderus

Inhaltsverzeichnis
Table of contents

Table de matieres
Indice

Inhoud
Indice

H65.2W-C	7 735 501 706	5
H65W	7 736 613 094	6
H65W	7 736 614 449	7
H65W	8 718 540 518	8
H65W MEE	7 736 613 095	9
H65WC	7 739 613 383	10
WU120 W	7 736 613 096	11
WU120W	7 719 003 021	12
WU120W-B	8 735 100 645	13
WU160W	7 719 003 022	14
WU160W	7 736 613 097	15
WU160W-B	8 735 100 646	16

Ersatzteilliste
Spare parts list
Liste des pièces de rechange
Lista parti di ricambio
Onderdelenlijst
Lista de repuestos

WU120 W - 7736613096

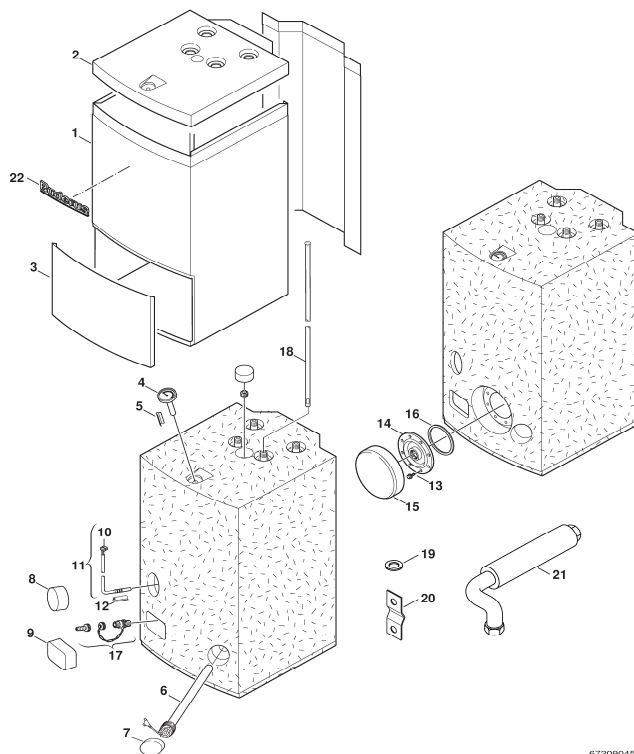

6720904582.a.a.R

Pos	Bestell-Nr.	Bezeichnung	Description	Dénomination	Descrizione	Benaming	Descripción
1	8 718 007 493 0	Mantel	Front shell	Habillage	Mantello	Mantel	Carcasa
2	8 715 503 570 0	Haube	Hood	Capot	Carpot	DEKSEL ST 120-2 E & EB	Capota
3	8 715 503 572 0	Abdeckung	Cover	Couvercle	Coperchio	Afdichting	Chapa de protección
4	8 717 208 111 0	Thermometer	Thermometer	Thermomètre	Termometro	THERMOMETER ST 120/160-2E-2EB	Termómetro
5	8 714 606 024 0	Klemmfeder (1x)	Clamp spring (1x)	RESSORT POUR THERMOMETRE (1x)	Fermo (1x)	KLEMMEER W/THERMOMETER ST/SO (1x)	Muelle fijación (1x)
6	8 718 505 052 0	Anode isoliert, 1" 480mm	Anode 1" 480MM	Anode 1" 480MM	Anodo 1" 480MM	Anode 1" 480MM	Anodo 1" 480MM
7	8 710 402 029 0	Kappe d: 85mm	Cap 85mm	Capot de protection 85mm	Calotta 85mm	Beschermkapje 85mm	Tapa 85mm
8	8 710 402 029 0	Kappe d: 85mm	Cap 85mm	Capot de protection 85mm	Calotta 85mm	Beschermkapje 85mm	Tapa 85mm
9	8 710 402 031 0	Isolierung	Insulation	Isolation	Isolamento	Isolatie	Aislamiento
10	8 711 006 060 0	Stecker	Plug	Connecteur	Spina	STEKKER NTC-VOELER ST...1E/SK 300ST.75	Aneccion
11	7 735 502 304	Temperaturfühler NTC RD 6.0 12K 6000mm	Temperature sensor NTC RD 6.0 12K 6000mm	Kit capteurs NTC RD 6.0 12K 6000 emballé	Sonda di temperatura NTC RD 6.0 12K 6000	Temperature Sensor 6x40,6000mm	Sensor temperatura NTC RD 6.0 12K 6000mm
12	8 714 606 021 0	Klemmfeder (1x)	Clamp spring (1x)	Ressort (1x)	Fermo (1x)	KLEMMEER NTC SK120/140/160-4ZB (1x)	Muelle de tecla (1x)
13	2 911 060 291 0	Schraube M10x25 (10x)	Screw M10x25 (10x)	Vis M10x25 (10x)	Vite M10x25 (10x)	Schroef M10x25 (10x)	Tornillo M10x25 (10x)
14	8 715 503 396 0	Flansch 1 1/2"	Connecting flange 1 1/2"	Trappe de visite 1 1/2"	Flangia 1 1/2"	Aansluitflens 1 1/2"	Brida de conexión 1 1/2"
15	8 718 006 674 0	Isolierung D212x45mm	Insulation D212x45mm	Isolation D212x45mm	Isolamento D212x45mm	Isolatie D212x45mm	Aislamiento D212x45mm
16	8 710 103 096 0	Dichtungs-Set 100x109D - 115/138Dx3 (1x)	Set of seals 100x109D - 115/138Dx3 (1x)	Jeu de joints 100x109D - 115/138Dx3 (1x)	Set guarnizioni 100x109D - 115/138Dx3	DICHTING FLENS SK...2ZB/-3ZB (VANAF 07/0)	Conjunto de juntas 100x109D - 115/138Dx3
17	8 738 505 974 0	Fuell- und Entleerventil	DFV	Robinet de remplissage et de vidange	Rubinetto di carico e scarico	Vul- en aftapkraan	Ilave de llenado y vaciado
18	8 735 100 005	Einlaufrohr 915mm	Inlet tube 915mm	Tube d'arrivée acier spécial 915mm	Tubo della presa acciaio raffinato 915mm	BUIS INTERN BOILERS 915mm	Pipa del producto acero afinado 915mm
19	8 710 103 043 0	Dichtung 23.9x17.2x1.5 (10x)	Washer 23.9x17.2x1.5 (10x)	Joint 23.9x17.2x1.5 (10x)	Guarnizione 23.9x17.2x1.5 (10x)	Afdichtring 23.9x17.2x1.5 (10x)	Junta 3/4" (5x)
20	8 711 301 131 0	Schelle (1x)	Clip (1x)	Support (1x)	Staffa (1x)	Klembeugel (1x)	Abrazadera (1x)
21	8 710 715 890 0	Schlauch	Hose	Flexible	Tubo flessibile	Slang	Tubo flexible
22	8 718 220 707 0	Logo Buderus	Trade mark badge Buderus	Marquage Buderus	Targhetta Buderus	Fabrieksmerk Buderus	Logotipo Buderus
For:							

Ersatzteilliste
Spare parts list
Liste des pièces de rechange
Lista parti di ricambio
Onderdelenlijst
Lista de repuestos

WU120W - 7719003021

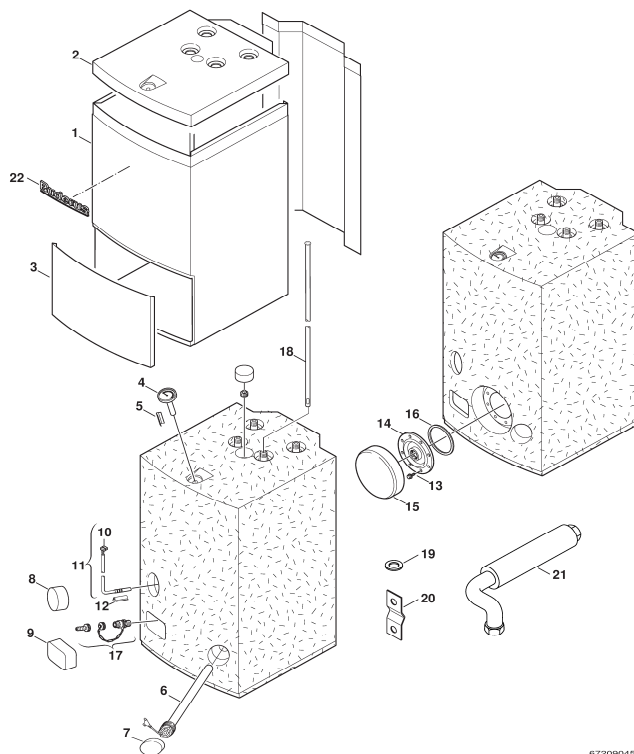

6720904582.a.a.R

Pos	Bestell-Nr.	Bezeichnung	Description	Dénomination	Descrizione	Benaming	Descripción
1	8 718 007 493 0	Mantel	Front shell	Habillage	Mantello	Mantel	Carcasa
2	8 715 503 570 0	Haube	Hood	Capot	Carpot	DEKSEL ST 120-2 E & EB	Capota
3	8 715 503 572 0	Abdeckung	Cover	Couvercle	Coperchio	Afdichting	Chapa de protección
4	8 717 208 111 0	Thermometer	Thermometer	Thermomètre	Termometro	THERMOMETER ST 120/160-2E-2EB	Termómetro
5	8 714 606 024 0	Klemmfeder (1x)	Clamp spring (1x)	RESSORT POUR THERMOMETRE (1x)	Fermo (1x)	KLEMMEER W/THERMOMETER ST/SO (1x)	Muelle fijación (1x)
6	8 718 505 052 0	Anode isoliert, 1" 480mm	Anode 1" 480MM	Anode 1" 480MM	Anodo 1" 480MM	Anode 1" 480MM	Anodo 1" 480MM
7	8 710 402 029 0	Kappe d: 85mm	Cap 85mm	Capot de protection 85mm	Calotta 85mm	Beschermkapje 85mm	Tapa 85mm
8	8 710 402 029 0	Kappe d: 85mm	Cap 85mm	Capot de protection 85mm	Calotta 85mm	Beschermkapje 85mm	Tapa 85mm
9	8 710 402 031 0	Isolierung	Insulation	Isolation	Isolamento	Isolatie	Aislamiento
10	8 711 006 060 0	Stecker	Plug	Connecteur	Spina	STEKKER NTC-VOELER ST...1E/SK 300ST.75	Aneccion
11	7 735 502 304	Temperaturfühler NTC RD 6.0 12K 6000mm	Temperature sensor NTC RD 6.0 12K 6000mm	Kit capteurs NTC RD 6.0 12K 6000 emballé	Sonda di temperatura NTC RD 6.0 12K 6000	Temperature Sensor 6x40,6000mm	Sensor temperatura NTC RD 6.0 12K 6000mm
12	8 714 606 021 0	Klemmfeder (1x)	Clamp spring (1x)	Ressort (1x)	Fermo (1x)	KLEMMEER NTC SK120/140/160-4ZB (1x)	Muelle de tecla (1x)
13	2 911 060 291 0	Schraube M10x25 (10x)	Screw M10x25 (10x)	Vis M10x25 (10x)	Vite M10x25 (10x)	Schroef M10x25 (10x)	Tornillo M10x25 (10x)
14	8 715 503 396 0	Flansch 1 1/2"	Connecting flange 1 1/2"	Trappe de visite 1 1/2"	Flangia 1 1/2"	Aansluitflens 1 1/2"	Brida de conexión 1 1/2"
15	8 718 006 674 0	Isolierung D212x45mm	Insulation D212x45mm	Isolation D212x45mm	Isolamento D212x45mm	Isolatie D212x45mm	Aislamiento D212x45mm
16	8 710 103 096 0	Dichtungs-Set 100x109D - 115/138Dx3 (1x)	Set of seals 100x109D - 115/138Dx3 (1x)	Jeu de joints 100x109D - 115/138Dx3 (1x)	Set guarnizioni 100x109D - 115/138Dx3	DICHTING FLENS SK...2ZB/-3ZB (VANAF 07/0)	Conjunto de juntas 100x109D - 115/138Dx3
17	8 738 505 974 0	Fuell- und Entleerventil	DFV	Robinet de remplissage et de vidange	Rubinetto di carico e scarico	Vul- en aftapkraan	llave de llenado y vaciado
18	8 735 100 005	Einlaufrohr 915mm	Inlet tube 915mm	Tube d'arrivée acier spécial 915mm	Tubo della presa acciaio raffinato 915mm	BUIS INTERN BOILERS 915mm	Pipa del producto acero afinado 915mm
19	8 710 103 043 0	Dichtung 23.9x17.2x1.5 (10x)	Washer 23.9x17.2x1.5 (10x)	Joint 23.9x17.2x1.5 (10x)	Guarnizione 23.9x17.2x1.5 (10x)	Afdichtring 23.9x17.2x1.5 (10x)	Junta 3/4" (5x)
20	8 711 301 131 0	Schelle (1x)	Clip (1x)	Support (1x)	Staffa (1x)	Klembeugel (1x)	Abrazadera (1x)
21	8 710 715 890 0	Schlauch	Hose	Flexible	Tubo flessibile	Slang	Tubo flexible
22	8 718 220 707 0	Logo Buderus	Trade mark badge Buderus	Marquage Buderus	Targhetta Buderus	Fabrieksmerk Buderus	Logotipo Buderus
For:							

Ersatzteilliste
Spare parts list
Liste des pièces de rechange
Lista parti di ricambio
Onderdelenlijst
Lista de repuestos

WU120W-B - 8735100645

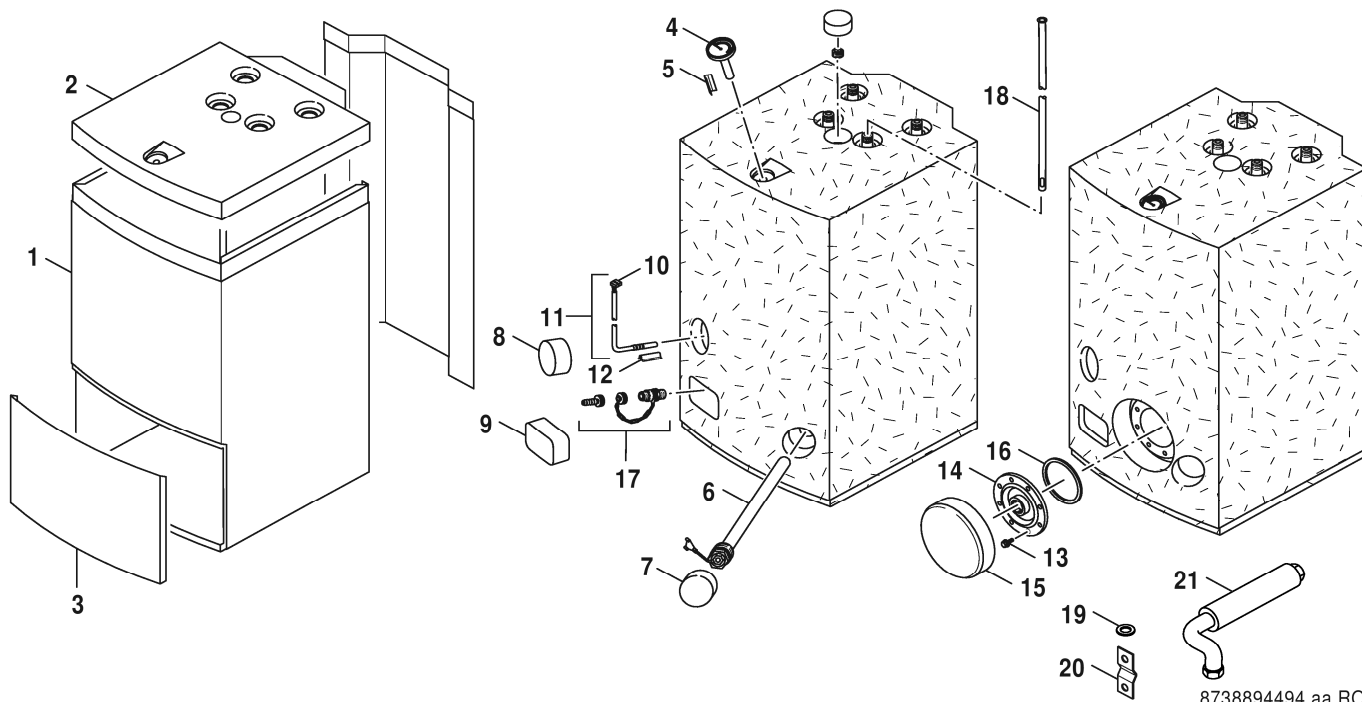

8738894494.aa.RO

Pos	Bestell-Nr.	Bezeichnung	Description	Dénomination	Descrizione	Benaming	Descripción
1	8 718 007 493 0	Mantel	Front shell	Habillage	Mantello	Mantel	Carcasa
2	8 715 503 570 0	Haube	Hood	Capot	Carpot	DEKSEL ST 120-2 E & EB	Capota
3	8 715 503 572 0	Abdeckung	Cover	Couvercle	Coperchio	Afdichting	Chapa de protección
4	8 717 208 111 0	Thermometer	Thermometer	Thermomètre	Termometro	THERMOMETER ST 120/160-2E-2EB	Termómetro
5	8 714 606 024 0	Klemmfeder (1x)	Clamp spring (1x)	RESSORT POUR THERMOMETRE (1x)	Fermo (1x)	KLEMMEER W/THERMOMETER ST/50 (1x)	Muelle fijación (1x)
6	8 718 505 052 0	Anode isoliert, 1" 480mm	Anode 1" 480MM	Anode 1" 480MM	Anodo 1" 480MM	Anode 1" 480MM	Anodo 1" 480MM
7	8 710 402 029 0	Kappe d: 85mm	Cap 85mm	Capot de protection 85mm	Calotta 85mm	Beschermkapje 85mm	Tapa 85mm
8	8 710 402 029 0	Kappe d: 85mm	Cap 85mm	Capot de protection 85mm	Calotta 85mm	Beschermkapje 85mm	Tapa 85mm
9	8 710 402 031 0	Isolierung	Insulation	Isolation	Isolamento	Isolatie	Aislamiento
10	8 711 006 060 0	Stecker	Plug	Connecteur	Spina	STEKKER NTC-VOELER ST.-1E/SK 300ST.75	Aneccion
11	7 735 502 304	Temperaturfühler NTC RD 6,0 12K 6000mm	Temperature sensor NTC RD 6,0 12K 6000mm	Kit capteurs NTC RD 6,0 12K 6000 emballé	Sonda di temperatura NTC RD 6,0 12K 6000	Temperature Sensor 6x40,6000mm	Sensor temperatura NTC RD 6,0 12K 6000mm
12	8 714 606 021 0	Klemmfeder (1x)	Clamp spring (1x)	Ressort (1x)	Fermo (1x)	KLEMMEER NTC SK120/140/160-4ZB (1x)	Muelle de tecla (1x)
13	2 911 060 291 0	Schraube M10x25 (10x)	Screw M10x25 (10x)	Vis M10x25 (10x)	Vite M10x25 (10x)	Schroef M10x25 (10x)	Tornillo M10x25 (10x)
14	8 715 503 396 0	Flansch 1 1/2"	Connecting flange 1 1/2"	Trappe de visite 1 1/2"	Flangia 1 1/2"	Aansluitflens 1 1/2"	Brida de conexión 1 1/2"
15	8 718 006 674 0	Isolierung D212x45mm	Insulation D212x45mm	Isolation D212x45mm	Isolamento D212x45mm	Isolatie D212x45mm	Aislamiento D212x45mm
16	8 710 103 096 0	Dichtungs-Set 100x109D - 115/138Dx3 (1x)	Set of seals 100x109D - 115/138Dx3 (1x)	Jeu de joints 100x109D - 115/138Dx3 (1x)	Set guarnizioni 100x109D - 115/138Dx3	DICHTING FLENS SK.-22B-32B (VANAF 07/0)	Conjunto de juntas 100x109D - 115/138Dx3
17	8 738 505 974 0	Fuell- und Entleerventil	DFV	Robinet de remplissage et de vidange	Rubinetto di carico e scarico	Vul- en aftapkraan	Ilave de llenado y vaciado
18	8 735 100 005	Einlaufrohr 915mm	Inlet tube 915mm	Tube d'arrivée acier spécial 915mm	Tubo della presa acciaio raffinato 915mm	BUIS INTERN BOILERS 915mm	Pipa del producto acero afinado 915mm
19	8 710 103 043 0	Dichtung 23.9x17.2x1.5 (10x)	Washer 23.9x17.2x1.5 (10x)	Joint 23.9x17.2x1.5 (10x)	Guarnizione 23.9x17.2x1.5 (10x)	Afdichting 23.9x17.2x1.5 (10x)	Junta 3/4" (5x)
20	8 711 301 131 0	Schelle (1x)	Clip (1x)	Support (1x)	Staffa (1x)	Klembeugel (1x)	Abrazadera (1x)
21	8 710 715 890 0	Schlauch	Hose	Flexible	Tubo flessibile	Slang	Tubo flexible
22	8 718 220 707 0	Logo Buderus	Trade mark badge Buderus	Marquage Buderus	Targhetta Buderus	Fabrieksmerk Buderus	Logotipo Buderus

For:

Ersatzteilliste
Spare parts list
Liste des pièces de rechange
Lista parti di ricambio
Onderdelenlijst
Lista de repuestos

WU160W - 7719003022

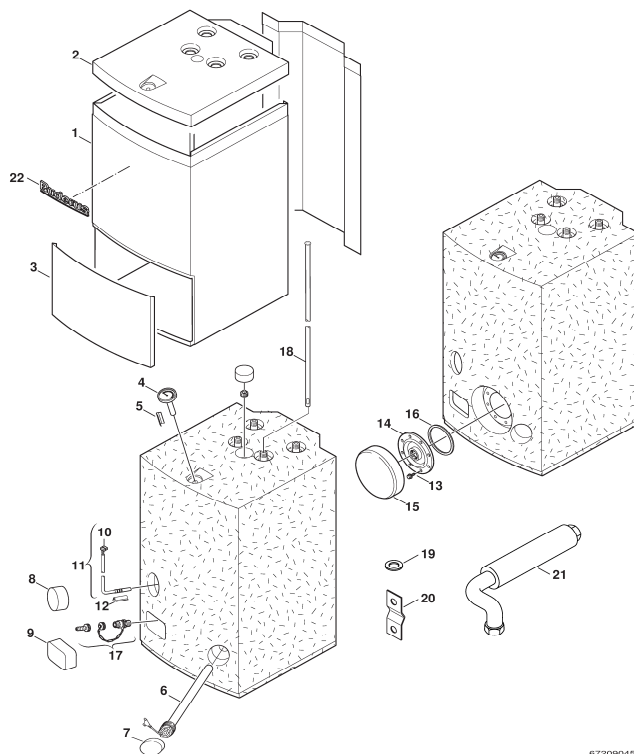

6720904562.a.a.R

Pos	Bestell-Nr.	Bezeichnung	Description	Dénomination	Descrizione	Benaming	Descripción
1	8 718 007 494 0	Mantel	Front shell	Habillage	Mantello	MANTEL VOOR ST 160-2EB 'STORACELL'	Carcasa
2	8 715 503 571 0	Haube	Hood	Capot	Carpot	DEKSEL ST 160-2E	Capota
3	8 715 503 573 0	Abdeckung	Cover	Couvercle	Coperchio	Afdichting	Chapa de protección
4	8 717 208 111 0	Thermometer	Thermometer	Thermomètre	Termometro	THERMOMETER ST 120/160-2E-2EB	Termómetro
5	8 714 606 024 0	Klemmfeder (1x)	Clamp spring (1x)	RESSORT POUR THERMOMETRE (1x)	Fermo (1x)	KLEMMEER W/THERMOMETRE ST/SO (1x)	Muelle fijación (1x)
6	8 718 505 052 0	Anode isoliert, 1" 480mm	Anode 1" 480MM	Anode 1" 480MM	Anodo 1" 480MM	Anode 1" 480MM	Anodo 1" 480MM
7	8 710 402 029 0	Kappe d: 85mm	Cap 85mm	Capot de protection 85mm	Calotta 85mm	Beschermkapje 85mm	Tapa 85mm
8	8 710 402 029 0	Kappe d: 85mm	Cap 85mm	Capot de protection 85mm	Calotta 85mm	Beschermkapje 85mm	Tapa 85mm
9	8 710 402 031 0	Isolierung	Insulation	Isolation	Isolamento	Isolatie	Aislamiento
10	8 711 006 060 0	Stecker	Plug	Connecteur	Spina	STEKKER NTC-VOELER ST...1E/SK 300ST.75	Aneccion
11	7 735 502 304	Temperaturfühler NTC RD 6.0 12K 6000mm	Temperature sensor NTC RD 6.0 12K 6000mm	Kit capteurs NTC RD 6.0 12K 6000 emballé	Sonda di temperatura NTC RD 6.0 12K 6000	Temperature Sensor 6x40,6000mm	Sensor temperatura NTC RD 6.0 12K 6000mm
12	8 714 606 021 0	Klemmfeder (1x)	Clamp spring (1x)	Ressort (1x)	Fermo (1x)	KLEMMEER NTC SK120/140/160-4ZB (1x)	Muelle de tecla (1x)
13	2 911 060 291 0	Schraube M10x25 (10x)	Screw M10x25 (10x)	Vis M10x25 (10x)	Vite M10x25 (10x)	Schroef M10x25 (10x)	Tornillo M10x25 (10x)
14	8 715 503 396 0	Flansch 1 1/2"	Connecting flange 1 1/2"	Trappe de visite 1 1/2"	Flangia 1 1/2"	Aansluitflens 1 1/2"	Brida de conexión 1 1/2"
15	8 718 006 674 0	Isolierung D212x45mm	Insulation D212x45mm	Isolation D212x45mm	Isolamento D212x45mm	Isolatie D212x45mm	Aislamiento D212x45mm
16	8 710 103 096 0	Dichtungs-Set 100x109D - 115/138Dx3 (1x)	Set of seals 100x109D - 115/138Dx3 (1x)	Jeu de joints 100x109D - 115/138Dx3 (1x)	Set guarnizioni 100x109D - 115/138Dx3	DICHTING FLENS SK...2ZB/-3ZB (VANAF 07/0)	Conjunto de juntas 100x109D - 115/138Dx3
17	8 738 505 974 0	Fuell- und Entleerventil	DFV	Robinet de remplissage et de vidange	Rubinetto di carico e scarico	Vul- en aftapkraan	llave de llenado y vaciado
18	8 735 100 005	Einlaufrohr 915mm	Inlet tube 915mm	Tube d'arrivée acier spécial 915mm	Tubo della presa acciaio raffinato 915mm	BUIS INTERN BOILERS 915mm	Pipa del producto acero afinado 915mm
19	8 710 103 043 0	Dichtung 23.9x17.2x1.5 (10x)	Washer 23.9x17.2x1.5 (10x)	Joint 23.9x17.2x1.5 (10x)	Guarnizione 23.9x17.2x1.5 (10x)	Afdichting 23.9x17.2x1.5 (10x)	Junta 3/4" (5x)
20	8 711 301 131 0	Schelle (1x)	Clip (1x)	Support (1x)	Staffa (1x)	Klembeugel (1x)	Abrazadera (1x)
21	8 710 715 890 0	Schlauch	Hose	Flexible	Tubo flessibile	Slang	Tubo flexible
22	8 718 220 707 0	Logo Buderus	Trade mark badge Buderus	Marquage Buderus	Targhetta Buderus	Fabrieksmerk Buderus	Logotipo Buderus
For:							

Ersatzteilliste
Spare parts list
Liste des pièces de rechange
Lista parti di ricambio
Onderdelenlijst
Lista de repuestos

WU160W - 7736613097

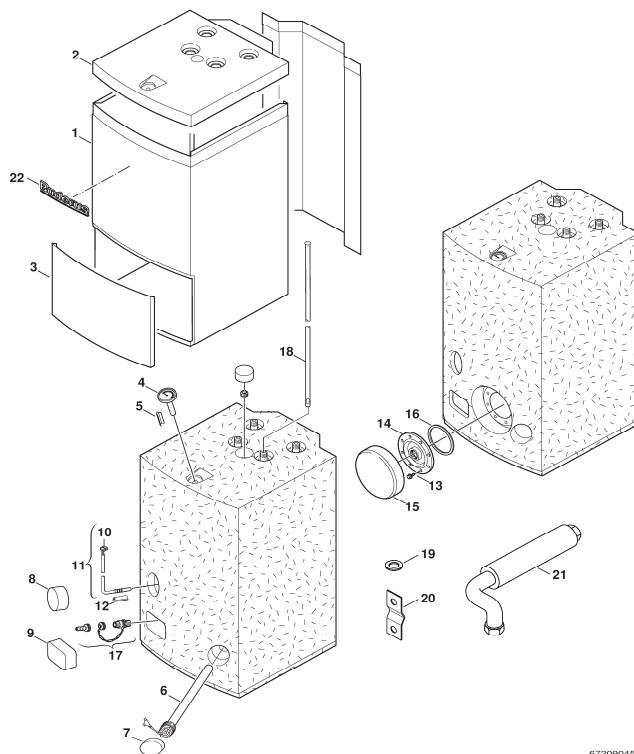

6720904562.a.a.R

Pos	Bestell-Nr.	Bezeichnung	Description	Dénomination	Descrizione	Benaming	Descripción
1	8 718 007 494 0	Mantel	Front shell	Habillage	Mantello	MANTEL VOOR ST 160-2EB 'STORACELL'	Carcasa
2	8 715 503 571 0	Haube	Hood	Capot	Carpot	DEKSEL ST 160-2E	Capota
3	8 715 503 573 0	Abdeckung	Cover	Couvercle	Coperchio	Afdichting	Chapa de protección
4	8 717 208 111 0	Thermometer	Thermometer	Thermomètre	Termometro	THERMOMETER ST 120/160-2E-2EB	Termómetro
5	8 714 606 024 0	Klemmfeder (1x)	Clamp spring (1x)	RESSORT POUR THERMOMETRE (1x)	Fermo (1x)	KLEMMEER W/THERMOMETRE ST/SO (1x)	Muelle fijación (1x)
6	8 718 505 052 0	Anode isoliert, 1" 480mm	Anode 1" 480MM	Anode 1" 480MM	Anodo 1" 480MM	Anode 1" 480MM	Anodo 1" 480MM
7	8 710 402 029 0	Kappe d: 85mm	Cap 85mm	Capot de protection 85mm	Calotta 85mm	Beschermkapje 85mm	Tapa 85mm
8	8 710 402 029 0	Kappe d: 85mm	Cap 85mm	Capot de protection 85mm	Calotta 85mm	Beschermkapje 85mm	Tapa 85mm
9	8 710 402 031 0	Isolierung	Insulation	Isolation	Isolamento	Isolatie	Aislamiento
10	8 711 006 060 0	Stecker	Plug	Connecteur	Spina	STEKKER NTC-VOELER ST...1E/SK 300ST.75	Aneccion
11	7 735 502 304	Temperaturfühler NTC RD 6.0 12K 6000mm	Temperature sensor NTC RD 6.0 12K 6000mm	Kit capteurs NTC RD 6.0 12K 6000 emballé	Sonda di temperatura NTC RD 6.0 12K 6000	Temperature Sensor 6x40,6000mm	Sensor temperatura NTC RD 6.0 12K 6000mm
12	8 714 606 021 0	Klemmfeder (1x)	Clamp spring (1x)	Ressort (1x)	Fermo (1x)	KLEMMEER NTC SK120/140/160-4ZB (1x)	Muelle de tecla (1x)
13	2 911 060 291 0	Schraube M10x25 (10x)	Screw M10x25 (10x)	Vis M10x25 (10x)	Vite M10x25 (10x)	Schroef M10x25 (10x)	Tornillo M10x25 (10x)
14	8 715 503 396 0	Flansch 1 1/2"	Connecting flange 1 1/2"	Trappe de visite 1 1/2"	Flangia 1 1/2"	Aansluitflens 1 1/2"	Brida de conexión 1 1/2"
15	8 718 006 674 0	Isolierung D212x45mm	Insulation D212x45mm	Isolation D212x45mm	Isolamento D212x45mm	Isolatie D212x45mm	Aislamiento D212x45mm
16	8 710 103 096 0	Dichtungs-Set 100x109D - 115/138Dx3 (1x)	Set of seals 100x109D - 115/138Dx3 (1x)	Jeu de joints 100x109D - 115/138Dx3 (1x)	Set guarnizioni 100x109D - 115/138Dx3	DICHTING FLENS SK...2ZB-3ZB (VANAF 07/0)	Conjunto de juntas 100x109D - 115/138Dx3
17	8 738 505 974 0	Fuell- und Entleerventil	DFV	Robinet de remplissage et de vidange	Rubinetto di carico e scarico	Vul- en aftapkraan	llave de llenado y vaciado
18	8 735 100 005	Einlaufrohr 915mm	Inlet tube 915mm	Tube d'arrivée acier spécial 915mm	Tubo della presa acciaio raffinato 915mm	BUIS INTERN BOILERS 915mm	Pipa del producto acero afinado 915mm
19	8 710 103 043 0	Dichtung 23.9x17.2x1.5 (10x)	Washer 23.9x17.2x1.5 (10x)	Joint 23.9x17.2x1.5 (10x)	Guarnizione 23.9x17.2x1.5 (10x)	Afdichtring 23.9x17.2x1.5 (10x)	Junta 3/4" (5x)
20	8 711 301 131 0	Schelle (1x)	Clip (1x)	Support (1x)	Staffa (1x)	Klembeugel (1x)	Abrazadera (1x)
21	8 710 715 890 0	Schlauch	Hose	Flexible	Tubo flessibile	Slang	Tubo flexible
22	8 718 220 707 0	Logo Buderus	Trade mark badge Buderus	Marquage Buderus	Targhetta Buderus	Fabrieksmerk Buderus	Logotipo Buderus
For:							

Ersatzteilliste
Spare parts list
Liste des pièces de rechange
Lista parti di ricambio
Onderdelenlijst
Lista de repuestos

WU160W-B - 8735100646

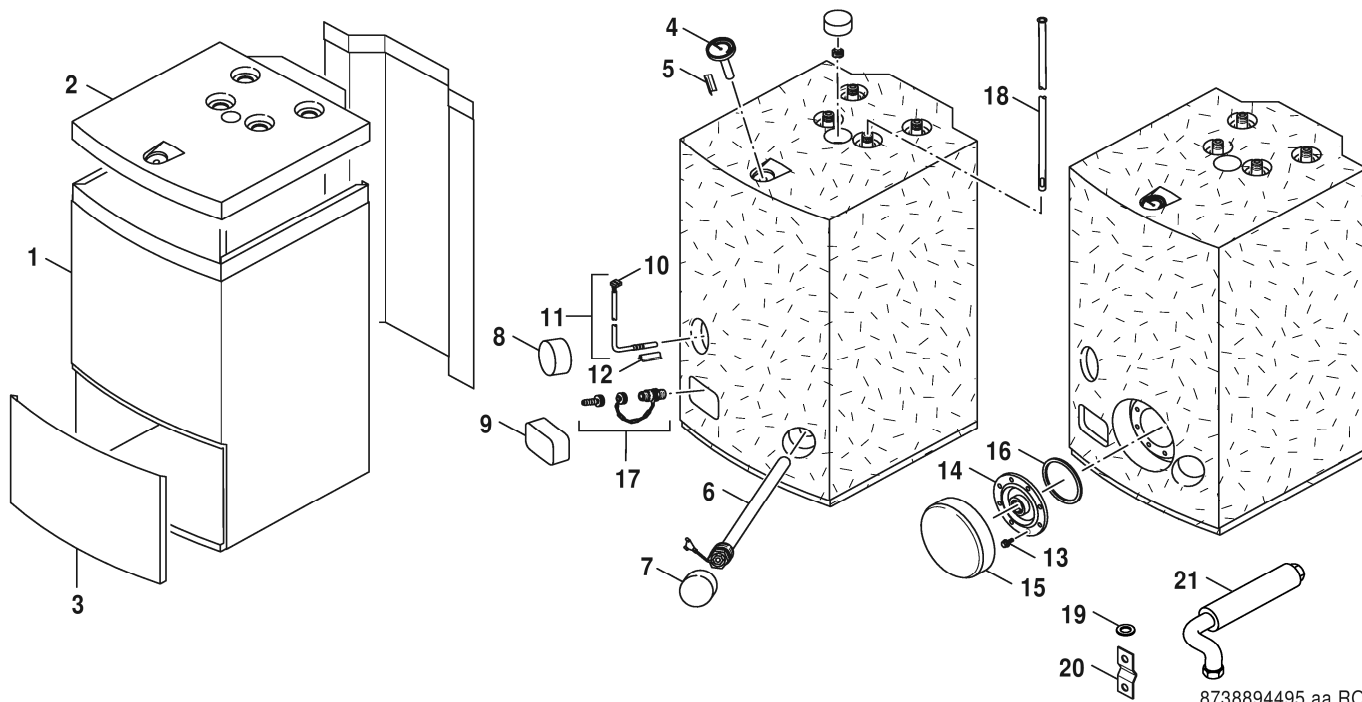

Pos	Bestell-Nr.	Bezeichnung	Description	Dénomination	Descrizione	Benaming	Descripción
1	8 718 007 494 0	Mantel	Front shell	Habillage	Mantello	MANTEL VOOR ST 160-2EB 'STORACELL'	Carcasa
2	8 715 503 571 0	Haube	Hood	Capot	Carpot	DEKSEL ST 160-2E	Capota
3	8 715 503 573 0	Abdeckung	Cover	Couvercle	Coperchio	Afdichting	Chapa de protección
4	8 717 208 111 0	Thermometer	Thermometer	Thermomètre	Termometro	THERMOMETER ST 120/160-2E-2EB	Termómetro
5	8 714 606 024 0	Klemmfeder (1x)	Clamp spring (1x)	RESSORT POUR THERMOMETRE (1x)	Fermo (1x)	KLEMMEER W/THERMOMETER ST/50 (1x)	Muelle fijación (1x)
6	8 718 505 052 0	Anode isoliert, 1" 480mm	Anode 1" 480MM	Anode 1" 480MM	Anodo 1" 480MM	Anode 1" 480MM	Anodo 1" 480MM
7	8 710 402 029 0	Kappe d: 85mm	Cap 85mm	Capot de protection 85mm	Calotta 85mm	Beschermkapje 85mm	Tapa 85mm
8	8 710 402 029 0	Kappe d: 85mm	Cap 85mm	Capot de protection 85mm	Calotta 85mm	Beschermkapje 85mm	Tapa 85mm
9	8 710 402 031 0	Isolierung	Insulation	Isolation	Isolamento	Isolatie	Aislamiento
10	8 711 006 060 0	Stecker	Plug	Connecteur	Spina	STEKKER NTC-VOELER ST...1E/SK 300ST.75	Aneccion
11	7 735 502 304	Temperaturfühler NTC RD 6.0 12K 6000mm	Temperature sensor NTC RD 6.0 12K 6000mm	Kit capteurs NTC RD 6.0 12K 6000 emballé	Sonda di temperatura NTC RD 6.0 12K 6000	Temperature Sensor 6x40,6000mm	Sensor temperatura NTC RD 6.0 12K 6000mm
12	8 714 606 021 0	Klemmfeder (1x)	Clamp spring (1x)	Ressort (1x)	Fermo (1x)	KLEMMEER NTC SK120/140/160-4ZB (1x)	Muelle de tecla (1x)
13	2 911 060 291 0	Schraube M10x25 (10x)	Screw M10x25 (10x)	Vis M10x25 (10x)	Vite M10x25 (10x)	Schroef M10x25 (10x)	Tornillo M10x25 (10x)
14	8 715 503 396 0	Flansch 1 1/2"	Connecting flange 1 1/2"	Trappe de visite 1 1/2"	Flangia 1 1/2"	Aansluitflens 1 1/2"	Brida de conexión 1 1/2"
15	8 718 006 674 0	Isolierung D212x45mm	Insulation D212x45mm	Isolation D212x45mm	Isolamento D212x45mm	Isolatie D212x45mm	Aislamiento D212x45mm
16	8 710 103 096 0	Dichtungs-Set 100x109D - 115/138Dx3 (1x)	Set of seals 100x109D - 115/138Dx3 (1x)	Jeu de joints 100x109D - 115/138Dx3 (1x)	Set guarnizioni 100x109D - 115/138Dx3	DICHTING FLENS SK...2ZB-3ZB (VANAF 07/0)	Conjunto de juntas 100x109D - 115/138Dx3
17	8 738 505 974 0	Fuell- und Entleerventil	DFV	Robinet de remplissage et de vidange	Rubinetto di carico e scarico	Vul- en aftapkraan	Ilave de llenado y vaciado
18	8 735 100 005	Einlaufrohr 915mm	Inlet tube 915mm	Tube d'arrivée acier spécial 915mm	Tubo della presa acciaio raffinato 915mm	BUIS INTERN BOILERS 915mm	Pipa del producto acero afinado 915mm
19	8 710 103 043 0	Dichtung 23.9x17.2x1.5 (10x)	Washer 23.9x17.2x1.5 (10x)	Joint 23.9x17.2x1.5 (10x)	Guarnizione 23.9x17.2x1.5 (10x)	Afdichting 23.9x17.2x1.5 (10x)	Junta 3/4" (5x)
20	8 711 301 131 0	Schelle (1x)	Clip (1x)	Support (1x)	Staffa (1x)	Klembeugel (1x)	Abrazadera (1x)
21	8 710 715 890 0	Schlauch	Hose	Flexible	Tubo flessibile	Slang	Tubo flexible
22	8 718 220 707 0	Logo Buderus	Trade mark badge Buderus	Marquage Buderus	Targhetta Buderus	Fabrieksmerk Buderus	Logotipo Buderus

For:

Bosch Thermotechnik GmbH
Sophienstr. 30-32
D-35576 Wetzlar / Germany

Buderus