

# S121 18-38kW /-WT

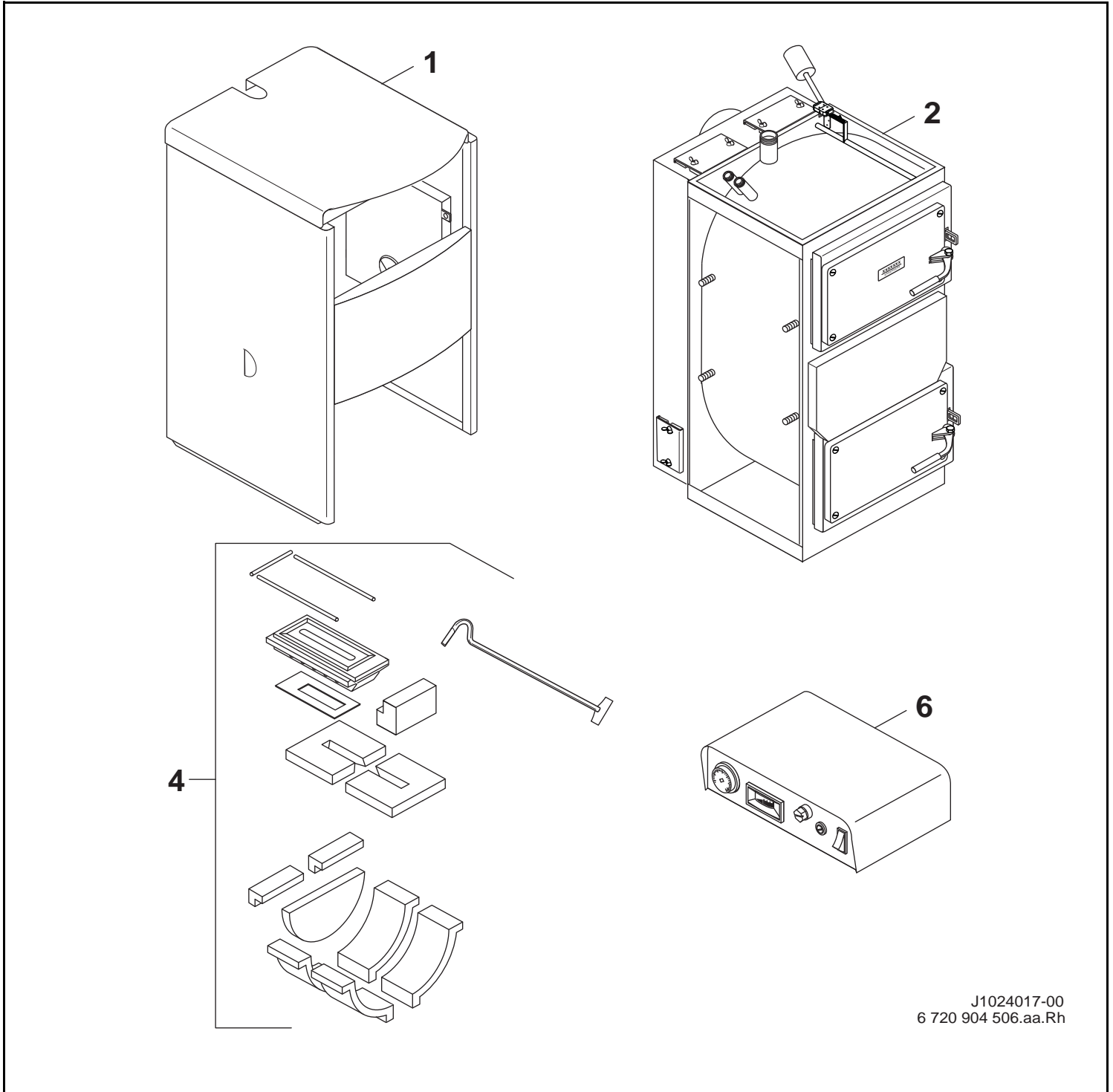

J1024017-00  
6 720 904 506.aa.Rh

# Buderus



### Wichtige Hinweise

- Ersatzteile dürfen nur von einem zugelassenen Installateur eingebaut werden!
- Im Anhang finden Sie:
  - die Übersetzungen aller verwendeten Teilebezeichnungen
  - eine Übersicht der Gerätetypen und Länder, für die diese Ersatzteilliste gilt.

### Important notes

- The spare parts may only be installed by an approved installer!
- In the appendix you will find:
  - a list of translations of the names of all parts used
  - a list of the models and countries to which this spare parts list applies.

### Indications importantes

- L'installation des pièces de rechange doit être effectuée par un professionnel qualifié!
- Veuillez trouver en annexe:
  - les traductions de toutes les désignations des pièces utilisées
  - une vue globale des types de chaudières et des pays pour lesquels la présente liste des pièces de rechange est valable.

### Informações importantes

- Peças de substituição só podem ser montadas por um técnico credenciado!
- Em anexo encontra:
  - as traduções das designações de todas as peças utilizadas.
  - lista dos aparelhos e países para os quais esta lista de peças de substituição é válida.

### Avvertenze importanti

- Le parti di ricambio possono essere montate esclusivamente da personale qualificato ed in possesso dei requisiti tecnico-professionali!
- In appendice sono reperibili:
  - traduzione di ogni descrizione relativa alle varie parti di ricambio
  - elenco di sigle e codici, corrispondente ai vari paesi di destinazione.

### Indicaciones importantes

- Los repuestos solamente deben ser montados por los servicios técnicos oficiales de la marca!
- En el anexo podrá encontrar:
  - la traducción de todas las denominaciones de piezas empleadas
  - una relación de los tipos de aparato y países en los que se aplica esta lista de repuestos.

### Belangrijke aanwijzing

- Onderdelen mogen alleen door een erkend installateur worden vervangen!
- In de bijlage vindt u:
  - de vertalingen van de gebruikte onderdelentekeningen
  - een overzicht van toesteltypen en de landen waarvoor deze onderdelenlijst bedoeld is.

### Önemli Bilgiler

- Yedek parçalar sadece yetkili tesisatçılar tarafından monte edilebilir!
- Aşağıdaki bilgileri ekli olarak bulabilirsiniz:
  - Tüm kullanılan parça tanımlarının tercümelemleri
  - Bu yedek parça listesinin geçerli olduğu tüm cihaz çeşitleri ve ülkelerin özeti.

Spare parts list  
Ersatzteilliste

Liste des pièces de rechange  
Lista parti di ricambio

Onderdelenlijst  
Lista de repuestos

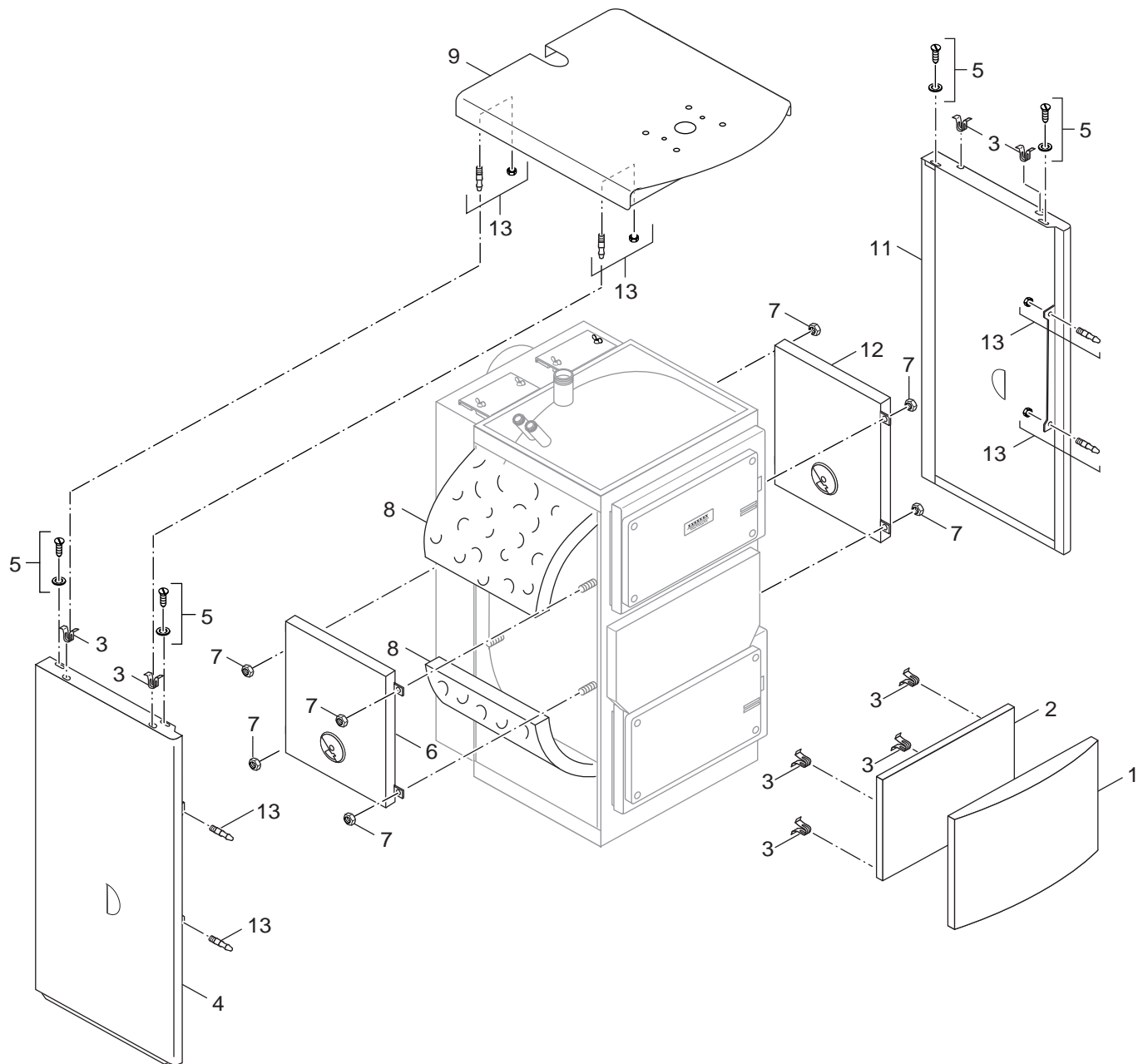

1024053-00  
6 720 904 507.aa.Rh

1

Sheet metal  
Blechteile  
Pièces de tôle  
Parti di lamiera  
Mantel  
Piezas de chapa

S121 18-38kW /-WT



Spare parts list  
Ersatzteilliste

Liste des pièces de rechange  
Lista parti di ricambio

Onderdelenlijst  
Lista de repuestos

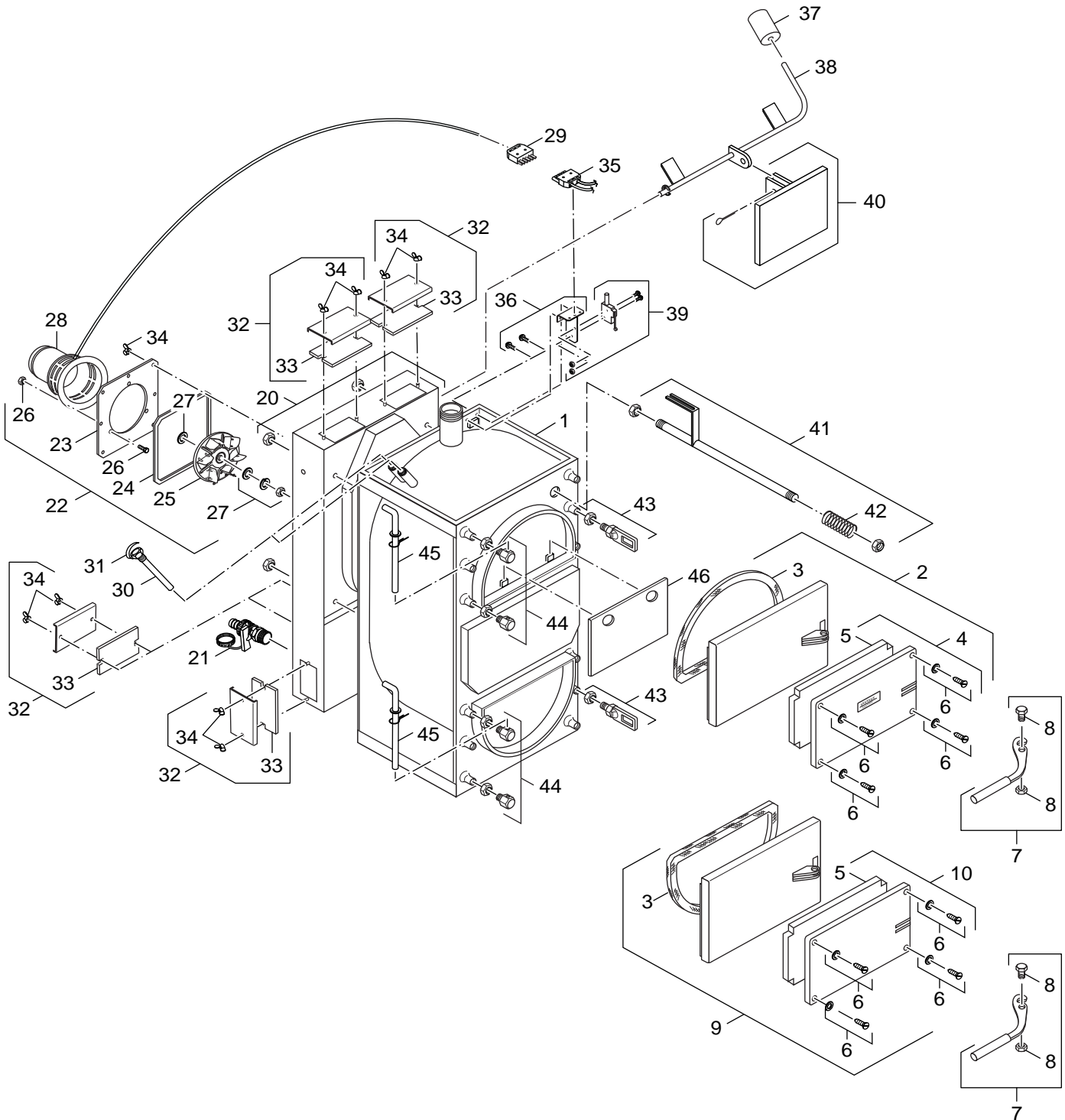

1024051-01  
6 720 904 508.ab.RS

**2**

Boiler bloc  
Kesselblock  
Corps de chauffe  
Corpo caldaia  
Ketelblok  
Cuerpo de caldera

**S121 18-38kW /-WT**

Pos	description Bezeichnung dénomination descrizioni benaming descripció	Ordering no. Bestell-Nr. Numero de commande n° d'ordine Bestelnummer Número el ordenar	S121-18kW	S121-18kW WT	S121-24kW	S121-24kW WT	S121-32kW	S121-32kW WT	S121-38kW	S121-38kW WT											Remarks Bemerkungen Remarques Osservazioni Opmerkingen Observaciones	
1	Boiler block without heat exchanger	8 739 930 365 0	■																			
1	Boiler block without heat exchanger	8 739 930 366 0			■																	
1	Boiler block without heat exchanger	8 739 930 367 0					■															
1	Boiler block without heat exchanger	8 739 930 368 0							■													
1	Boiler block with heat exchanger	8 739 930 369 0		■																		
1	Boiler block with heat exchanger	8 739 930 370 0				■																
1	Boiler block with heat exchanger	8 739 930 371 0							■													
1	Boiler block with heat exchanger	8 739 930 372 0									■											
2	charge door 18-24kW	8 738 101 017	■	■	■	■																
2	charge door 32-38kW	8 738 101 018					■	■	■	■												
3	Packing cord 20x20x1235	8 738 120 906 0	■	■	■	■																
3	Packing cord 20x20x1430	8 738 120 907 0					■	■	■	■												
4	protecting plate charge door 18-24kW	8 738 101 019	■	■	■	■																
4	protecting plate charge door 32-38kW	8 738 101 020					■	■	■	■												
5	Insulation	8 739 930 379 0	■	■	■	■																
5	Insulation	8 739 930 380 0					■	■	■	■												
6	Fixing set	8 739 930 482 0	■	■	■	■	■	■	■	■												
7	Handle	8 739 930 386 0	■	■	■	■	■	■	■	■												
8	Fixing set	8 739 930 483 0	■	■	■	■	■	■	■	■												
9	Ash door 18/24kW	8 738 101 021	■	■	■	■																
9	Ash door 32/38kW	8 738 101 022					■	■	■	■												
10	protecting plate Ash door 18/24kW	8 738 101 023	■	■	■	■																
10	protecting plate Ash door 32-38kW	8 738 101 024					■	■	■	■												
20	Flue gas collector	8 739 930 414 0	■	■	■	■																
20	Flue gas collector	8 739 930 415 0					■	■														
20	Flue gas collector	8 739 930 416 0							■	■												
21	fill and drain tap G1/2"	8 738 100 902	■	■	■	■	■	■	■	■												
22	Fan	8 738 120 942 0	■	■	■	■	■	■	■	■												
23	Connecting flange	8 739 930 419 0	■	■	■	■	■	■	■	■												
24	Packing cord 8x8x845	8 738 120 908 0	■	■	■	■	■	■	■	■												
25	Blower wheel	8 739 930 421 0	■	■	■	■	■	■	■	■												
26	Fixing set	8 739 930 422 0	■	■	■	■	■	■	■	■												
27	Fixing set impeller	8 738 121 771 0	■	■	■	■	■	■	■	■												
28	Motor	8 739 930 424 0	■	■	■	■	■	■	■	■												
29	Plug	8 739 930 425 0	■	■	■	■	■	■	■	■												
30	Sensor pocket	8 739 930 518 0	■	■	■	■	■	■	■	■												
31	Fixing bracket	8 739 930 537 0	■	■	■	■	■	■	■	■												
32	Cleaning cover	8 739 930 435 0	■	■	■	■	■	■	■	■												
33	Insulation	8 739 930 434 0	■	■	■	■	■	■	■	■												
34	Nut M6	8 739 930 428 0	■	■	■	■	■	■	■	■												
35	Sleeve	8 739 930 429 0	■	■	■	■	■	■	■	■												
36	Fixing set	8 739 930 427 0	■	■	■	■	■	■	■	■												
37	Weight 500g	8 739 930 430 0	■	■	■	■	■	■	■	■												
38	Lever	8 739 930 431 0	■	■	■	■																
38	Lever	8 739 930 432 0					■	■	■	■												
39	Microswitch	8 739 930 433 0	■	■	■	■	■	■	■	■												
40	Air flap	8 739 930 498 0	■	■	■	■	■	■	■	■												
41	Gear rod	8 739 930 436 0	■	■																		
41	Gear rod	8 739 930 437 0			■	■																
41	Gear rod	8 739 930 438 0					■	■														
41	Gear rod	8 739 930 439 0							■	■												
42	Spring	8 739 930 440 0	■	■	■	■	■	■	■	■												
<b>S121 18-38kW /-WT</b>							Boiler bloc Kesselblock Corps de chauffe Corpo caldaia Ketelblok Cuerpo de caldera															

Spare parts list  
Ersatzteilliste

Liste des pièces de rechange  
Lista parti di ricambio

Onderdelenlijst  
Lista de repuestos

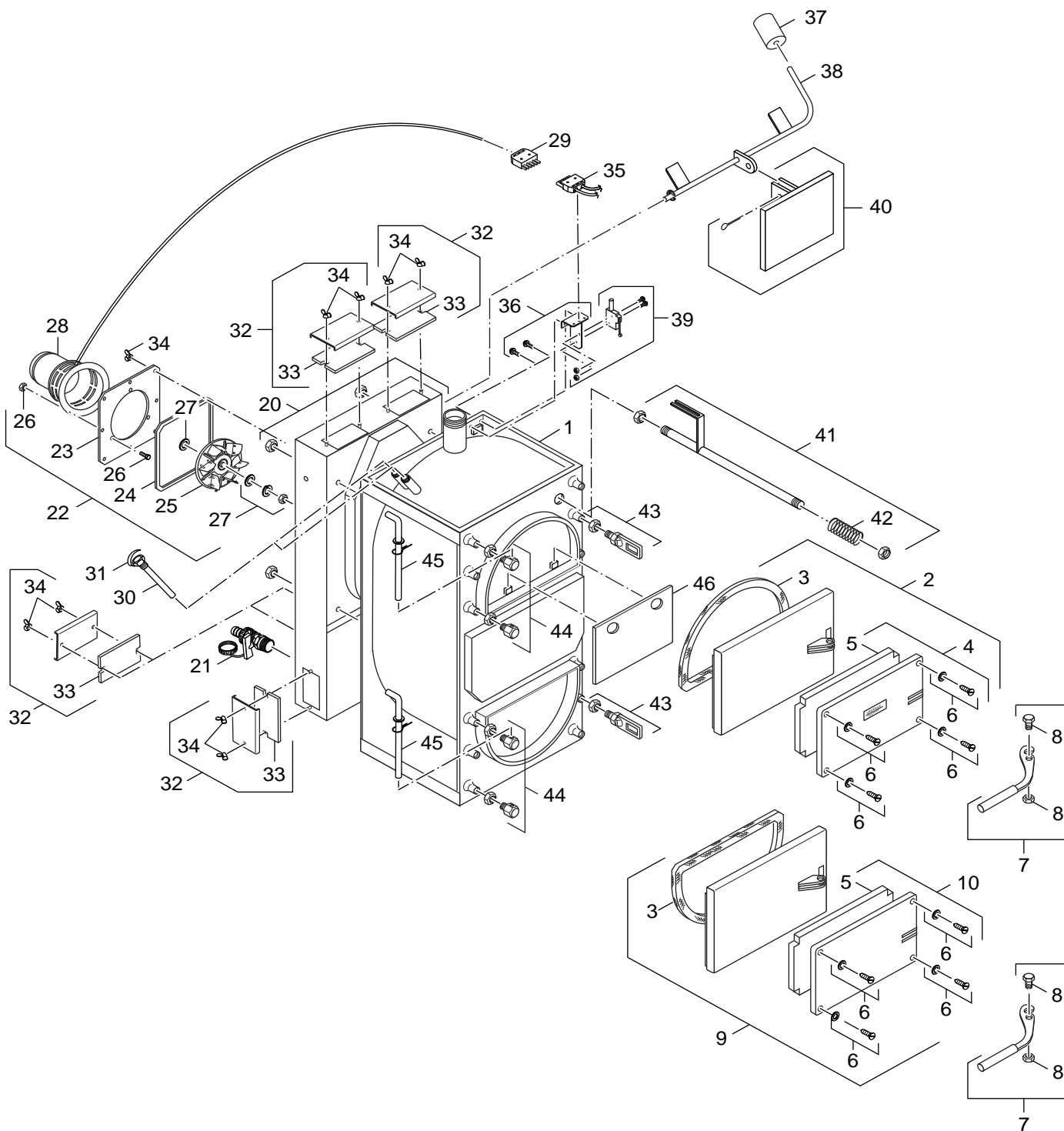

1024051-01  
6 720 904 508.ab.RS

2

Boiler bloc  
Kesselblock  
Corps de chauffe  
Corpo caldaia  
Ketelblok  
Cuerpo de caldera

S121 18-38kW /-WT



Pos	description Bezeichnung dénomination descrizioni benaming descripción	Ordering no. Bestell-Nr. Numero de commande n° d'ordine Bestelnummer Número el ordenar	S121-18kW	S121-18kW WT	S121-24kW	S121-24kW WT	S121-32kW	S121-32kW WT	S121-38kW	S121-38kW WT											Remarks Bemerkungen Remarques Osservazioni Opmerkingen Observaciones
43	Lock	8 739 930 441 0	■	■	■	■	■	■	■	■											
44	Fixing set	8 739 930 442 0	■	■	■	■	■	■	■	■											
45	Hinge rod	8 738 120 463 0	■	■	■	■															
45	hinge rod	8 738 120 464 0					■	■	■	■											
46	Protecting plate	8 739 930 385 0	■	■	■	■	■	■	■	■											
	Silicon cartridge	8 718 223 050 0	■	■	■	■	■	■	■	■											
	fire clay 1Kg	8 739 930 032 0	■	■	■	■	■	■	■	■											
<b>S121 18-38kW /-WT</b>											Boiler bloc Kesselblock Corps de chauffe Corpo caldaia Ketelblok Cuerpo de caldera										

Spare parts list  
Ersatzteilliste

Liste des pièces de rechange  
Lista parti di ricambio

Onderdelenlijst  
Lista de repuestos

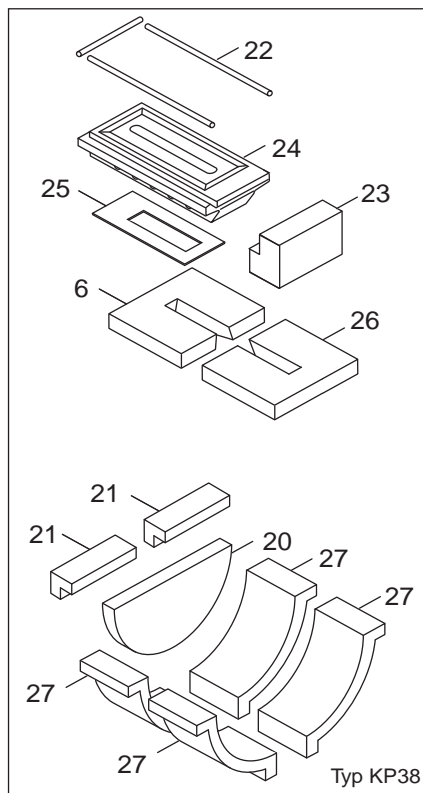
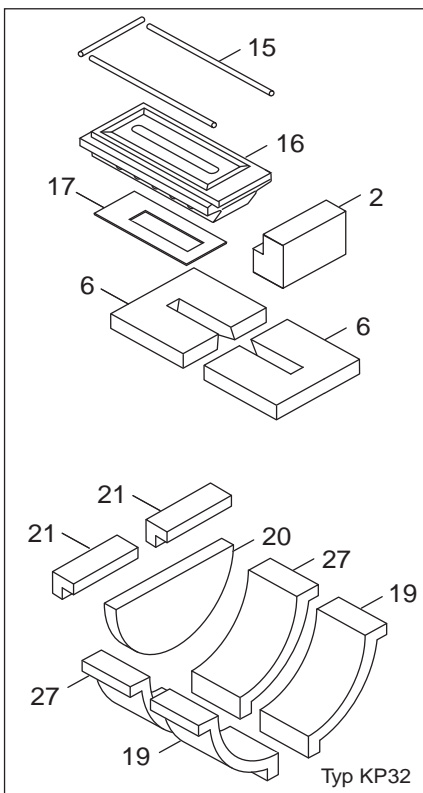
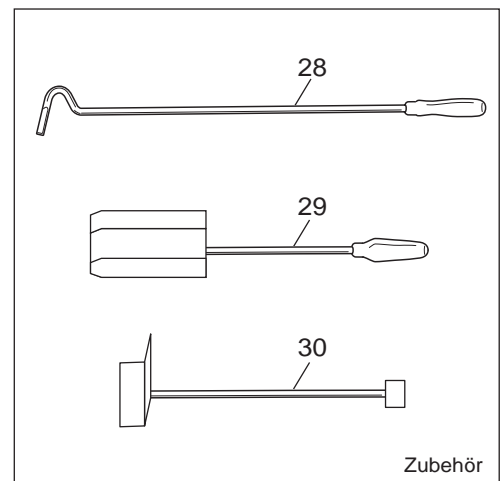
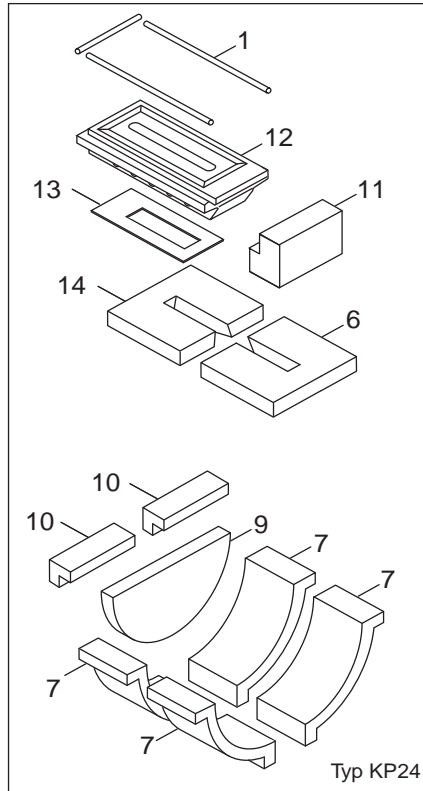
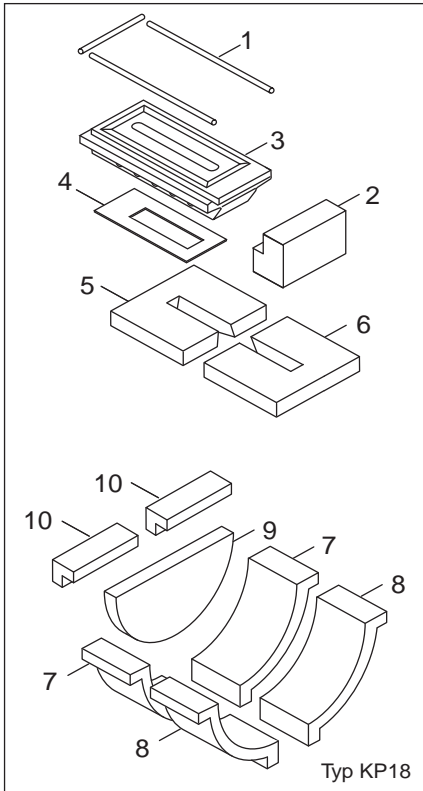

1024052-00  
6 790 904 534.aa.Rh

4

Accessories  
Zubehör  
Accessoires  
Accesorios  
Toebehoren  
Accesorios

S121 18-38kW /-WT



Spare parts list  
Ersatzteilliste

Liste des pièces de rechange  
Lista parti di ricambio

Onderdelenlijst  
Lista de repuestos

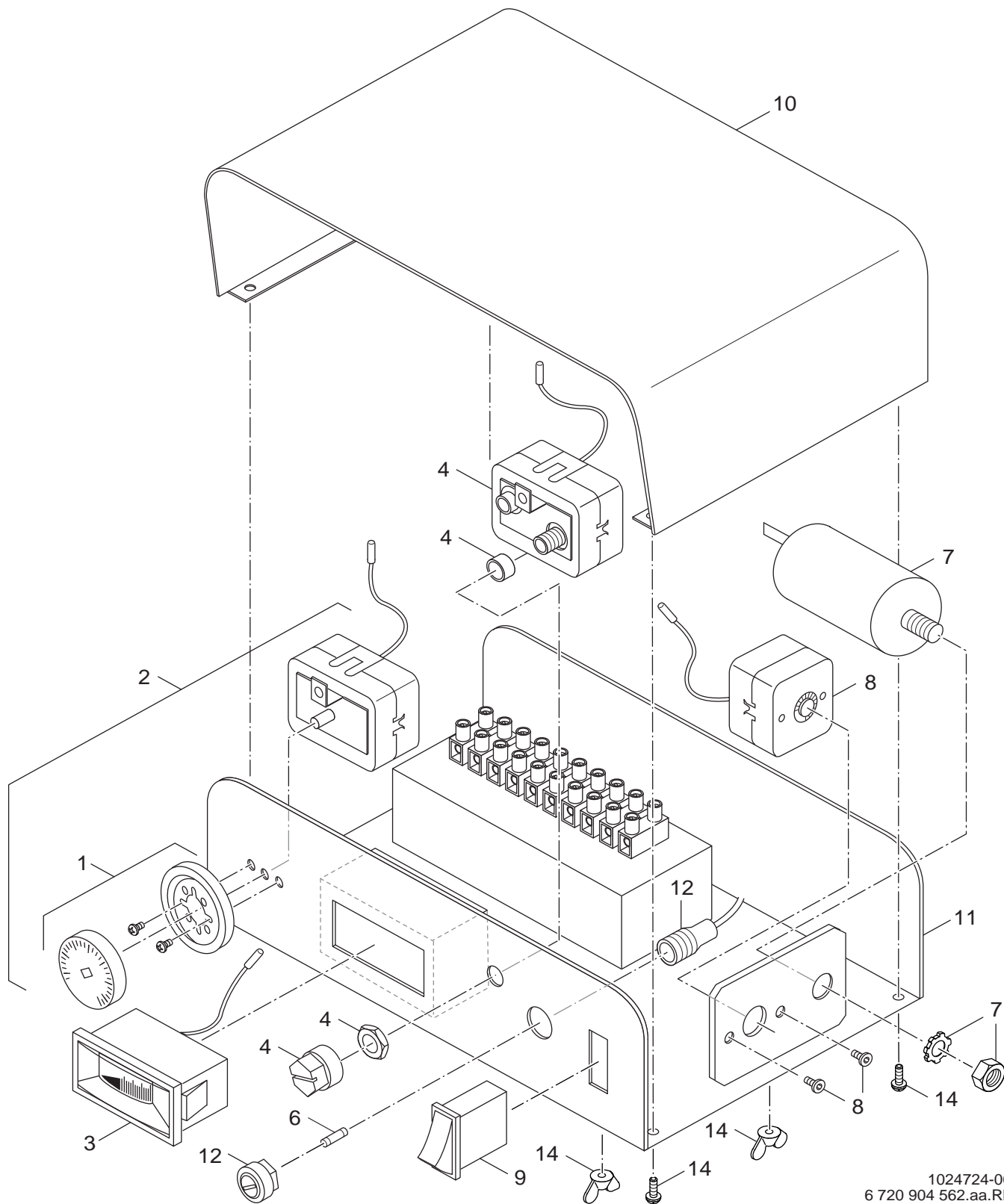

1024724-00  
6 720 904 562.aa.Rh

**S121 18-38kW /-WT**

**6**

Control box  
Schaltkasten  
Tableau de commande  
Quadro comandi  
Schakelkast  
Caja de conexiones



List of translations Übersetzungsliste		Liste des traductions Traduzione delle descrizioni		Vertalinglijst Lista de traducciones	
Pos	Beschreibung	Denomination	Descrizione	Benaming	Descripción
<b>1</b>	<b>Baugruppe</b>	<b>Groupe de construction</b>	<b>Gruppo di costruzione</b>	<b>Montagegroep</b>	<b>Grupo de construcción</b>
1	Vorderwand 18/24 blau	Panneau frontal 18/24 bleu	Frontalino 18/24 blu	Frontplaat 18/24 blauw	panel frontal 18/24 azul
2	Isolierung	Isol av S121-32/38 V2	Isolamento	Isolatie	Aislamiento
3	Klammer (1x)	Clip de fixation (1x)	Graffa (1x)	Klem (1x)	Grapa (1x)
4	Seitenwand 18 links blau	Paroi latérale 18 gauche bleu	Parete laterale 18 sinistra blu	Zijwand 18 Links blauw	Pared lateral 18 izquierda azul
5	Befestigungssatz	SET DE FIXATION S121	Set di fissaggio	Bevestigingsset	Juego piezas de fijacion
6	Seitenwand innen links	PANNEAU INT. GAUCHE S121	Panello laterale sinistra	Zijpaneel links	Pared lateral izquierda
7	Mutter M6 DIN 936	Ecrou M6 DIN 936	Dado M6 DIN 936	Moer M6 DIN 936	Tuerca M6 DIN 936
8	Isolierung	Isolation	Isolamento	Isolatie	Aislamiento
9	Haube 18 blau	Capot 18 bleu	Coperchio 18 blu	afdekkap 18 blauw	capota 18 azul
11	Seitenwand 18 rechts blau	Paroi latérale 18 droite bleu	Parete laterale 18 destra blu	Zijwand 18 Rechts blauw	Pared lateral 18 derecha azul
12	Seitenwand innen rechts	Côté droit	Panello laterale a destra	Zijpaneel rechts	Pared lateral derecha
13	Befestigungssatz (4 Stifte)	Jeu de pièces de fixation (4 Goupille)	Set di fissaggio (4 Spina)	Bevestigingsset (4 Stift)	Juego piezas de fijacion (4 clavijas)
	Silikonkartusche	Cartouche de silicone	Cartuccia di silicone	Siliconencartouche	Cartucho silicone
<b>2</b>	<b>Baugruppe</b>	<b>Groupe de construction</b>	<b>Gruppo di costruzione</b>	<b>Montagegroep</b>	<b>Grupo de construcción</b>
1	Kesselblock ohne Wärmetauscher 18kW	Corps de chauffe sans échangeur chaleur	Corpo caldaia senza scambiatore calore	Ketelblok zonder warmtewisselaar	Bloque de la caldera sin intercamb calor
2	Fülltür 18-24kW komplett blau	porte de remplissage 18-24kW	porta di carico 18-24kW	vuideur 18-24Kw	puerta de llenado 18-24kW
3	Dichtschnur 20x20x1235	Cordon d'étanchéité 20x20x1235	Cordone di tenuta 20x20x1235	Afdichtkoord 20x20x1235	Cordón de estanqueidad 20x20x1235
4	Schutzplatte Fülltür 18-24kW blau	Plaque de protection porte remplissage	Piastra di protezione porta carico 18-24	Beschermings plaat vuideur 18-24kW	placa protectora puerta de llenado 18-24kW
5	Isolierung	Isol de porte S121-18/24kW	Isolamento	Isolatie	Aislamiento
6	Befestigungssatz	Jeu de pièces de fixation	Set di fissaggio	Bevestigingsset	Juego piezas de fijacion
7	Griff	Poignée S121	Manopola	Knop	Mando del grifo
8	Befestigungssatz	JEU DE PIÈCES DE FIXATION S121	Set di fissaggio	Bevestigingsset	Juego piezas de fijacion
9	Aschetür 18/24kW blau	Porte de cendres 18/24kW	Porta 18/24kW	Deur 18/24kW	Puerta 18/24kW
10	Schutzplatte Aschetür 18-24kW blau	Plaque de protection Porte de cendres	Piastra di protezione Deur 18/24kW	Beschermings plaat Painel frontal 18/24kW	placa protectora Porta 18/24kW
20	Abgassammler	Buse de fumee S121-18/24	Cappa fumi	Valwindafleider	Seguro evacuación de gases
21	Füllhahn G1/2"	robinet de remplissage et vidange G1/2"	rubinetto di carico e scarico G1/2"	vul- en aftapkraan G1/2"	grifo de llenado y de vaciado G1/2"
22	Gebälse	Ventilateur	Ventilatore	ventilator	ventilador
23	Flansch	Trappe de visite	Flangia	Aansluitflens	Brida de conexión
24	Dichtschnur 8x8x845	Cordon d'étanchéité 8x8x845	Cordone di tenuta 8x8x845	Afdichtkoord 8x8x845	Cordón de estanqueidad 8x8x845
25	Gebälserad	Roue ventil	Rotella di ventilatore	Ventilator	Rueda de soplador
26	Befestigungssatz	Jeu de pièces de fixation	Set di fissaggio	Bevestigingsset	Juego piezas de fijacion
27	Befestigungssatz Gebläserad	Jeu de pièces de fixation Turbine extrac	Set di fissaggio Ventola del ventilatore	Bevestigingsset schoepenrad van de venti	Juego piezas de fijacion turbina del ven
28	Motor	MOTEUR VENTIL S121	Motore	Motor	Motor
29	Stecker	Connecteur	Spina	Stekker	Aneccion
30	Tauchhülse	Douille	Boccola	Dompelhuls	Casquillo de la caldera
31	Halterung	Support	Supporto	Houder	Sujeción
32	Reinigungsdeckel	Trappe de visite	Coperchio nero	Coperchio di pulizia	Tapa de limpieza
33	Isolierung	ISOLATION S121	Isolamento	Isolatie	Aislamiento
34	Mutter M6	Ecrou M6	Dado M6	Moer M6	Tuerca M6
35	Buchse	Douille	Buccola	Huls	Manguito
36	Haltesatz	Jeu de support	Set di aggancio	Set steunbeugel	Conjunto angulo soporte
37	Gewicht 500g	Poids 500g	Peso 500g	Gewicht 500g	Peso 500g
38	Hebel	Levier	Leva	Kniehefboom	Palanca
39	Mikroschalter	Microrupteur S121 V2	Microinterruttore	Microschakelaar	Microinterruptor
40	Luftklappe	Clapet air	Dispositivo di regolazione dell'aria	Luchtklep	Tapa de aire
41	Schaltstange	Tige de commande	Asta di comando	Schakelstang	Barra de conexión
42	Feder	Ressort	Molla	Klemveer	Barra de conexión
43	Verschluss	Fermeture porte cpl S121 V2	Chiusura	Afsluiting	Cerradura
44	Befestigungssatz	Jeu de pièces de fixation	Set di fissaggio	Bevestigingsset	Juego piezas de fijacion
45	Scharnierstange	Tige de charnière	Perno delle cerniere	Scharnierstang	Barra de la bisagra
46	Schutzplatte	Plaque de protection S121	Protecting plate	Protecting plate	Protecting plate
	Silikonkartusche	Cartouche de silicone	Cartuccia di silicone	Siliconencartouche	Cartucho silicone
	Schamott 1Kg	Chamotte 1Kg	Matton refrattario 1Kg	Vuurvaste steen 1Kg	Material refractario 1Kg
<b>4</b>	<b>Baugruppe</b>	<b>Groupe de construction</b>	<b>Gruppo di costruzione</b>	<b>Montagegroep</b>	<b>Grupo de construcción</b>
1	Dichtschnur 20x20x202 2x20x20x380	Cordon d'étanchéité 20x20x202 2x20x20x380	Cordone di tenuta 20x20x202 2x20x20x380	Afdichtkoord 20x20x202 2x20x20x380	Cordón de estanqueidad 20x20x202 2x20x20x380
2	Schamottstein L74mm	BRIQUE REFRACTAIRE L=74 S121-18/32 V2	Mattone aluminoso L74mm	Vuurvaste steen L74mm	Ladrillo refractario L74mm



Types of appliances Gerätetypen	Types de chaudières Tipo apparecchi	Toesteltypen Tipos de aplicaciones	
Appliance Gerät Chaudière Apparecchio Toestel Aparato	Ordering no. Bestell-Nr. Numero de commande n° d'ordine Bestelnummer Número el ordenar	Country Land Pay Paese Land Paese	Remarks Bemerkungen Remarques Osservazioni Opmerkingen Observaciones
<b>S121-18KW WT BG</b>	30009423	Bulgaria	
<b>S121-24KW WT BG</b>	30009424	Bulgaria	
<b>S121-32KW WT BG</b>	30009425	Bulgaria	
<b>S121-38KW WT BG</b>	30009426	Bulgaria	
<b>S121-18KW WT HR</b>	30009410	Croatia	
<b>S121-24KW WT HR</b>	30009411	Croatia	
<b>S121-32KW WT HR</b>	30009412	Croatia	
<b>S121-38KW WT HR</b>	30009413	Croatia	
<b>S121-18KW CZ</b>	7 747 308 185	Czech Republic	
<b>S121-18KW WT CZ</b>	7 747 308 189	Czech Republic	
<b>S121-24KW CZ</b>	7 747 308 186	Czech Republic	
<b>S121-24KW WT CZ</b>	7 747 308 190	Czech Republic	
<b>S121-32KW CZ</b>	7 747 308 187	Czech Republic	
<b>S121-32KW WT CZ</b>	7 747 308 191	Czech Republic	
<b>S121-38KW CZ</b>	7 747 308 188	Czech Republic	
<b>S121-38KW WT CZ</b>	7 747 308 192	Czech Republic	
<b>S121-18KW WT EE</b>	30009414	Estonia	
<b>S121-18KW WT EE</b>	30009418	Estonia	
<b>S121-24KW WT EE</b>	30009415	Estonia	
<b>S121-32KW WT EE</b>	30009416	Estonia	
<b>S121-38KW WT EE</b>	30009417	Estonia	
<b>S121-24KW HU</b>	30009401	Hungary	
<b>S121-32KW HU</b>	30009402	Hungary	
<b>S121-38KW HU</b>	30009403	Hungary	
<b>S121-18KW WT IT</b>	7 747 300 807	Italy	
<b>S121-24KW WT IT</b>	7 747 300 808	Italy	
<b>S121-32KW WT IT</b>	7 747 300 809	Italy	
<b>S121-38KW WT IT</b>	7 747 300 810	Italy	



Types of appliances Gerätetypen	Types de chaudières Tipo apparecchi	Toesteltypen Tipos de aplicaciones	
Appliance Gerät Chaudière Apparecchio Toestel Aparato	Ordering no. Bestell-Nr. Numero de commande n° d'ordine Bestelnummer Número el ordenar	Country Land Pay Paese Land Paese	Remarks Bemerkungen Remarques Osservazioni Opmerkingen Observaciones
<b>S121-18KW WT LT</b>	30009419	Lithuania	
<b>S121-24KW WT LT</b>	30009420	Lithuania	
<b>S121-32KW WT LT</b>	30009421	Lithuania	
<b>S121-38KW WT LT</b>	30009422	Lithuania	
<b>S121-18KW WT XS</b>	7 747 300 940	Montenegro,Serbia	
<b>S121-18KW XS</b>	7 747 300 936	Montenegro,Serbia	
<b>S121-24KW WT XS</b>	7 747 300 941	Montenegro,Serbia	
<b>S121-24KW XS</b>	7 747 300 937	Montenegro,Serbia	
<b>S121-32KW WT XS</b>	7 747 300 942	Montenegro,Serbia	
<b>S121-32KW XS</b>	7 747 300 938	Montenegro,Serbia	
<b>S121-38KW WT XS</b>	7 747 300 943	Montenegro,Serbia	
<b>S121-38KW XS</b>	7 747 300 939	Montenegro,Serbia	
<b>S121-18KW WT NZ</b>	7 742 110 065	New Zealand	
<b>S121-24KW WT NZ</b>	7 742 110 066	New Zealand	
<b>S121-32KW WT NZ</b>	7 742 110 067	New Zealand	
<b>S121-38KW WT NZ</b>	7 742 110 068	New Zealand	
<b>S121-24KW PL</b>	30009326	Poland	
<b>S121-32KW PL</b>	30009327	Poland	
<b>S121-38KW PL</b>	30009328	Poland	
<b>S121-18KW WT RO</b>	30009329	Romania	
<b>S121-24KW WT RO</b>	30009404	Romania	
<b>S121-32KW WT RO</b>	30009331	Romania	
<b>S121-38KW WT RO</b>	30009405	Romania	
<b>S121-18KW WT SI</b>	30009406	Slovenia	
<b>S121-24KW WT SI</b>	30009407	Slovenia	
<b>S121-32KW WT SI</b>	30009408	Slovenia	
<b>S121-38KW WT SI</b>	30009409	Slovenia	

Types of appliances Gerätetypen	Types de chaudières Tipo apparecchi	Toesteltypes Tipos de aplicaciones	
Appliance Gerät Chaudière Apparecchio Toestel Aparato	Ordering no. Bestell-Nr. Numero de commande n° d'ordine Bestelnummer Número el ordenar	Country Land Pay Paese Land Paese	Remarks Bemerkungen Remarques Osservazioni Opmerkingen Observaciones
<b>S121-18KW WT</b>	82000800		Name plate
<b>S121-24KW WT</b>	82000802		Name plate
<b>S121-32KW WT</b>	82000804		Name plate
<b>S121-38KW WT</b>	82000806		Name plate
<b>S121-18KW</b>	82000808		Name plate
<b>S121-24KW</b>	82000810		Name plate
<b>S121-32KW</b>	82000812		Name plate
<b>S121-38KW</b>	82000814		Name plate



Bosch Thermotechnik GmbH  
Sophienstraße 30-32  
D-35576 Wetzlar  
[www.buderus.de](http://www.buderus.de)

**Buderus**