

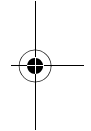

**8 707 207 277 0 / 8 707 207 308 0 / 8 707 207 309 0**  
**8 707 207 310 0 / 8 707 207 311 0 / 8 707 207 313**

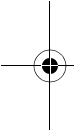

<b>Português</b>	<b>2</b>	<b>Italiano</b>	<b>15</b>
<b>Español</b>	<b>5</b>	<b>Greek</b>	<b>19</b>
<b>English</b>	<b>8</b>	<b>Dutch</b>	<b>23</b>
<b>Français</b>	<b>11</b>	<b>Turkish</b>	<b>26</b>

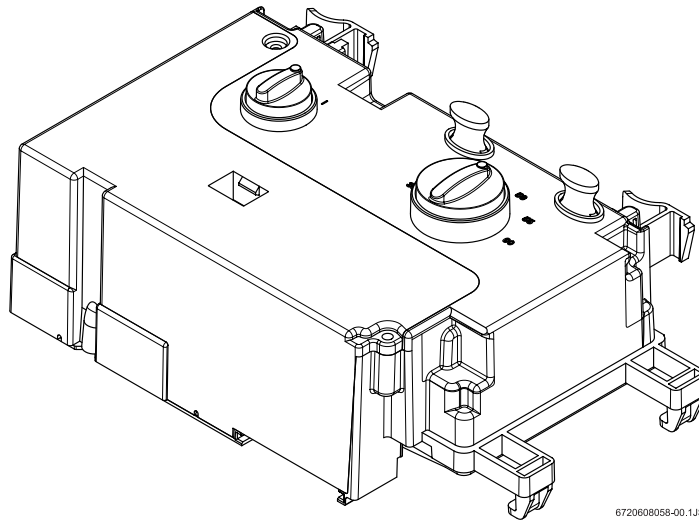
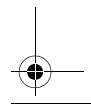
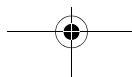
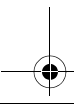

## Regulação do gás

Com a aplicação da nova caixa/placa electrónica, algumas das acções descritas no manual de instalação do aparelho sofreram alteração. Ver abaixo novos procedimentos.

### 1 Regulação do gás

#### 1.1 Regulação de fábrica



Os órgãos selados não devem ser violados.

#### Gás natural

Os aparelhos para gás natural H (G 20) são fornecidos selados depois de terem sido regulados na fábrica para os valores que figuram na placa de características.



Os aparelhos não devem ser postos em funcionamento se a pressão de ligação for inferior a 15 mbar ou superior a 25 mbar.

#### Gás líquido

Os aparelhos para propano/butano (G31/G30) são fornecidos selados depois de terem sido regulados na fábrica para os valores que figuram na placa de características.



**Perigo:** as operações em seguida descritas só deverão ser efectuadas por um técnico qualificado.

É possível afinar a potência segundo o processo da pressão do queimador, para tal é necessário um manómetro com tubos comunicantes em U.

#### 1.2 Regulação de pressão

##### Acesso ao parafuso de ajuste

- ▶ Retirar a frente do aparelho.

- ▶ Pressionar simultaneamente as patilhas (A) e puxar a caixa de comando.

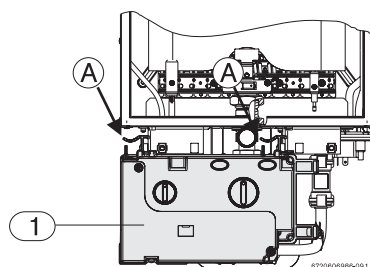

Fig. 1 Retirar a caixa de comando

- ▶ Uma vez a caixa de comando retirada, posicioná-la de acordo com a Fig. 2.

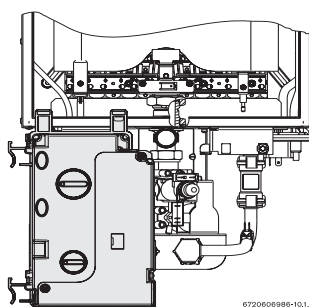

Fig. 2 Caixa de comando - posição de ajuste de gás

##### Conexão do manómetro

- ▶ Desapertar o parafuso obturador (1).
- ▶ Ligar o manómetro de tubos em U ao ponto de medição para a pressão do queimador.

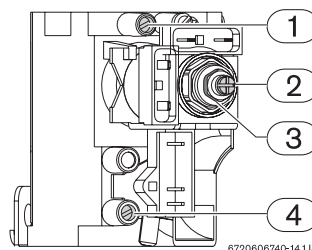

Fig. 3 Pontos de medição de pressão

## Regulação do gás

- 1 Ponto de medição para a pressão do queimador
- 2 Parafuso de ajuste do caudal mínimo de gás
- 3 Porca de ajuste do caudal máximo de gás
- 4 Ponto de medição para a pressão de ligação do gás

### Ajuste do caudal de gás máximo

Interruptor principal na posição 0.

- ▶ Colocar o selector de temperatura na posição 6 (posição 60 na caixa de comando).
- ▶ Pressionar e manter pressionada a tecla estado do queimador e colocar o interruptor principal na posição I.

Depois de manter a tecla pressionada durante aproximadamente 10 segundos, o aparelho encontra-se em posição de ajuste para caudal máximo, a tecla estado do queimador pisca.

- ▶ Abrir a torneira de água quente.
- ▶ Utilizando a porca de ajuste (Fig. 3, pos. 3) regular a pressão até atingir os valores indicados na Tabela 1.



Depois de feita a regulação, deixe o aparelho funcionar no caudal máximo durante aproximadamente 30 segundos.

### Ajuste do caudal de gás mínimo

Interruptor principal na posição 0.



O ajuste do caudal mínimo só é necessário caso o queimador se apague frequentemente quando se reduz o caudal de água.

- ▶ Colocar o selector de temperatura na posição 1 (posição 35 na caixa de comando).
- ▶ Pressionar e manter pressionada a tecla estado do queimador e colocar o interruptor principal na posição I.

Depois de manter a tecla pressionada durante aproximadamente 10 segundos, o aparelho encontra-se em posição de ajuste para caudal mínimo, a tecla estado do queimador pisca.

- ▶ Abrir a torneira de água quente.
- ▶ Utilizando o parafuso de ajuste (Fig. 3, pos. 2) regular a pressão até atingir os valores indicados na Tabela 1.

		Gás natural H	But	Prop
Código do injector	WT11	8708202116 (125)	8708202127 (74)	
	WT14	8708202124 (120)		
Pressão de ligação (mbar)	WT11	20	30	37
	WT14			
Pressão do queimador MAX (mbar)	WT11	10	26	34
	WT14	13		36
Pressão do queimador MIN (mbar)	WT11	2	4	5
	WT14	2	3	4

Tab. 1 Pressão do queimador

## 1.3 Optimização de performance

A nova electrónica elimina a necessidade de se efectuar o processo de optimização de performance.

## 1.4 Mudança do tipo de gás

Utilizar apenas os kits de conversão de origem. A conversão só deve ser efectuada por um técnico credenciado. Os kits de conversão de origem são fornecidos com instruções de montagem.

- ▶ Fechar a válvula de gás.
- ▶ Desligar o interruptor principal do aparelho e desmontar a frente.

## Regulação do gás

- ▶ Desmontar o queimador.

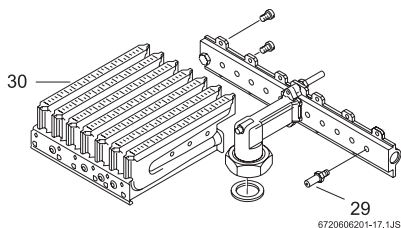

Fig. 4

- ▶ Desmontar ambas as rampas de injectores e substituir os injectores.
- ▶ Montar o queimador.
- ▶ Verificar que não há fugas de gás.
- ▶ Abrir a caixa electrónica.
- ▶ Posicionar o "jumper" de acordo com a tabela 2.

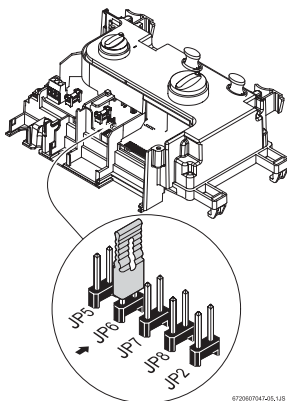

Fig. 5 Jumper (configuração para gás natural)

- ▶ Registrar a modificação do tipo de gás na placa de características do aparelho.

JP6	Tipo de gás
Com jumper	Gás Natural
Sem jumper	GPL

Tab. 2 Configuração do jumper - tipo de gás

## 1.5 Campo de ajuste da temperatura

O campo de ajuste do aparelho está definido para 35°C - 60°C. Colocando o jumper JP7, o campo de ajuste é alterado para 38°C - 50°C.

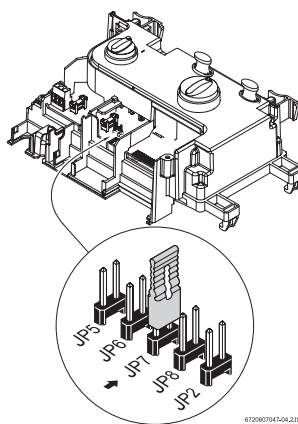

Fig. 6 Configuração do jumper - campo de ajuste da temperatura

## 1.6 Retardar arranque

Colocando o jumper JP2, o aparelho só efectua o arranque após 3 segundos de detecção de caudal de arranque.

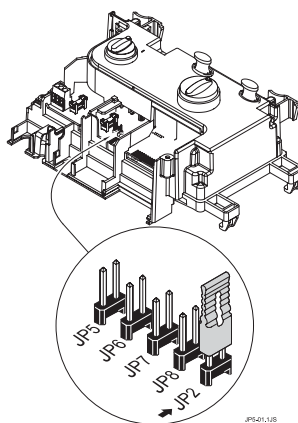

Fig. 7 Configuração do jumper - retardar arranque

Con la nueva caja electrónica, algunas de las acciones descritas en el manual de instalación del aparato sufrieron alteraciones. Ver abajo nuevos procedimientos.

## 1 Ajustes

### 1.1 Ajuste de fábrica



No se deben abrir las unidades selladas.

#### Gas natural

Los aparatos para gas natural (G 20) se suministran sellados después de regularse en fábrica para los valores que figuran en la chapa de características.



Los aparatos no se deben poner en funcionamiento si la presión de conexión es inferior a 15 mbar o superior a 25 mbar.

#### Gas líquido

Los aparatos para propano/butano (G31/G30) se suministran sellados después de regularse en fábrica para los valores que figuran en la chapa de características.



**Peligro:** Las operaciones descritas a continuación sólo deben ser efectuadas por un técnico cualificado.

Se puede ajustar la potencia según el método de la presión del quemador. Para ello, es necesario un manómetro de columna de agua.

### 1.2 Regulación de la presión

#### Acceso al tornillo de ajuste

- ▶ Retire la parte frontal del aparato.

- ▶ Presione simultáneamente las pestañas (A) y tire de la caja de mando.

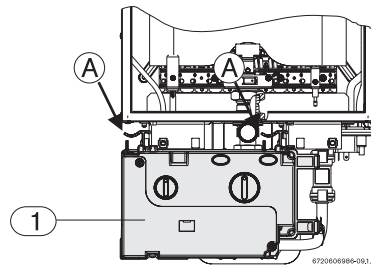

Fig. 1 Retirada de la caja de mando

- ▶ Una vez retirada la caja de mando, colóquela de acuerdo con la Fig. 2.

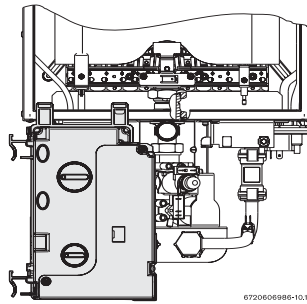

Fig. 2 Caja de mando - posición de ajuste del gas

#### Conexión del manómetro

- ▶ Afloje el tornillo obturador (1).
- ▶ Conecte el manómetro de tubos en U al punto de medición para la presión del quemador.

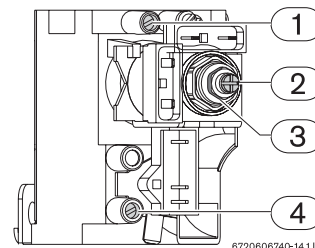

Fig. 3 Puntos de medición de presión

## Ajustes

- 1 Punto de medición para la presión del quemador
- 2 Tornillo de ajuste del caudal mínimo de gas
- 3 Tuerca de ajuste del caudal máximo de gas
- 4 Punto de medición para la presión de conexión del gas

### Ajuste del caudal de gas máximo

Interruptor principal en la posición 0.

- ▶ Colocar el selector de temperatura en la posición 6 (posición 60 en la caja de mando).
- ▶ Pulse y mantenga pulsada la tecla estado del quemador y colocar el interruptor principal en la posición I.

Después de presionar la tecla estado del quemador pelo menos por 10 segundos, el aparato se encuentra en posición de ajuste para caudal máximo, la tecla estado del quemador parpadea.

- ▶ Abra el grifo de agua caliente.
- ▶ Utilizando la tuerca de ajuste (Fig. 3, pos. 3) regule la presión hasta alcanzar los valores indicados en la tabla 1.



Después de la regulación, mantenga el calentador funcionando a potencia máxima por al menos 30 segundos.

### Ajuste del caudal de gas mínimo

Interruptor principal en la posición 0.



El ajuste del caudal mínimo sólo es necesario si el quemador se apaga frecuentemente cuando se reduce el caudal de agua.

- ▶ Colocar el seletor de temperatura en la posición 1 (posición 35 en la caja de mando).
- ▶ Pulse y mantenga pulsada la tecla estado del quemador y colocar el interruptor principal en la posición I.

Después de presionar la tecla estado del quemador pelo menos por 10 segundos, el

aparato se encuentra en posición de ajuste para caudal mínimo, la tecla estado del quemador parpadea.

- ▶ Abra el grifo de agua caliente.
- ▶ Utilizando el tornillo de ajuste (Fig. 3, pos. 2) regule la presión hasta alcanzar los valores indicados en la tabla 1.

		Gas natural H	But	Prop
Código del inyector	WT11	8708202116 (125)	8708202127 (74)	
	WT14	8708202124 (120)		
Presión de conexión (mbar)	WT11	20	28	37
	WT14			
Presión del quemador MAX (mbar)	WT11	10	26	34
	WT14			
Presión del quemador rmin (mbar)	WT11	2	4	5
	WT14			

Tabla 1 Presión del quemador

## 1.3 Optimización del rendimiento

A nova electrónica elimina a necessidade de se efectuar o processo de optimização de performance.

## 1.4 Cambio del tipo de gas

Utilice sólo los juegos de conversión originales. La conversión sólo debe ser efectuada por un técnico autorizado. Los juegos de conversión originales se suministran con instrucciones de montaje.

- ▶ Cierre la llave del gas.
- ▶ Desconecte el interruptor principal del aparato y desmonte la parte frontal.

- Desmonte el quemador.

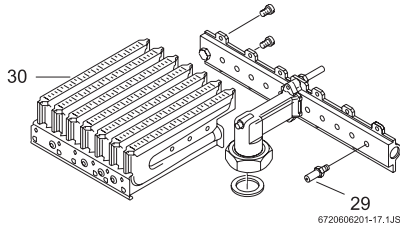

Fig. 4

- Desmonte las dos rampas de inyectores y cambie los inyectores.
- Monte el quemador.
- Compruebe que no haya fugas de gas.
- Abra la tapa de la caja electrónica.
- Seleccione el puente de acuerdo a la tabla 2.

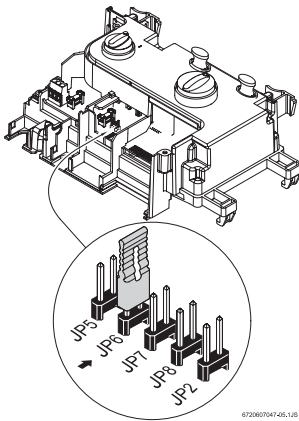

Fig. 5 Puente (configuración para gas natural)

- Anote la modificación del tipo de gas en la placa de características del aparato.

JP6	Tipo de gas
Con puente	Gas Natural
Sin puente	GLP

Tabla 2 Configuración del puente según el tipo de gas

### 1.5 Selección del rango de temperatura

El rango de temperatura del calefón es fijado entre 35°C y 60°C. Utilizando el puente JP7, el rango de temperatura cambia entre 38°C a 50°C.

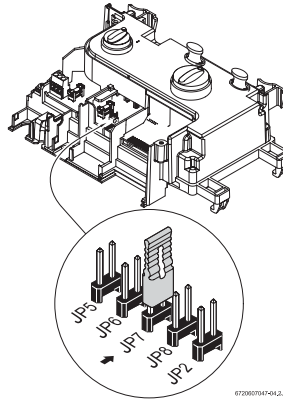

Fig. 6 Selección del rango de temperatura

### 1.6 Retardo de encendido

Cerrando el puente JP2, el quemador enciende después de 3 seg de la detección de demanda de agua caliente. (recomendado para casos de encendidos persistentes por golpe de ariete).

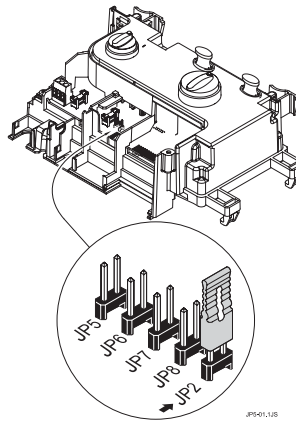

Fig. 7 Configuración del puente - retardo de encendido

## Gas regulation

With the new electronics, some of the actions described in the installation manual were changed. Below are described the new procedures.

# 1 Gas regulation

## 1.1 Factory regulations



Sealed parts must not be interfered with.

### Natural gas

Heaters designed for Natural gas H (G 20) are factory sealed for delivery after the values on the characteristics panel have been checked.



Heaters should not be ignited when the coupling pressure is less than 15 mbar more than 25 mbar.

### Liquid gas

Propane/butane heaters (G31/G30) are factory sealed for delivery after the values on the characteristics panel have been checked.



**Danger:** The following operations must be carried out by a qualified technician.

Power may be tuned according to the burner pressure process, for which a manometer with U-shaped connecting tubes is required.

## 1.2 Pressure regulation

### Access to the adjuster screw

- ▶ Remove the appliance front cover.

- ▶ Press both tabs (A) simultaneously and pull the control box.

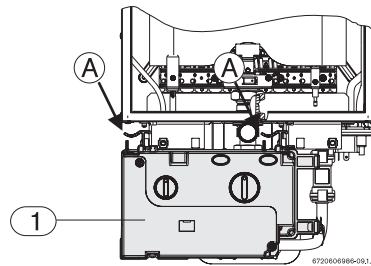

Fig. 1 Remove the control box

- ▶ Once the control box is removed, place it as in Fig. 2.

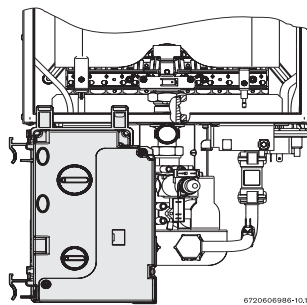

Fig. 2 Control box – gas adjustment position

### Connection of manometer

- ▶ Loosen the shutter screw (1).
- ▶ Connect the U-tube manometer to the burner pressure measuring point.

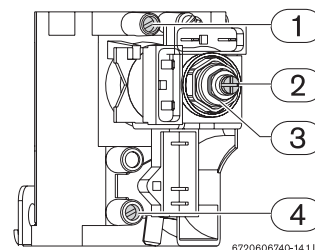

Fig. 3 Pressure measuring points

- 1 Burner pressure measuring point



## Gas regulation

- 2 Minimum gas flow adjustment screw
- 3 Maximum gas flow adjuster
- 4 Gas supply pressure measuring point

### Maximum gas flow adjustment

Main switch in position 0.

- ▶ Set temperature regulator to position 6 (position 60 in control box).
- ▶ Press and hold the burner state key and set the main switch in position I.

After pressing burner state key for at least 10 seconds, the appliance is in maximum flow position and the burner state key flashes.

- ▶ Open the hot water tap.
- ▶ Using the adjuster (Fig. 3, pos. 3) regulate the pressure to achieve the values indicated in table 1.



After regulating, let the appliance operate at maximum power for at least 30 secs.

### Minimum gas flow adjustment

Main switch in position 0.



Minimum flow adjustment is only necessary if the burner frequently goes out when the water flow is reduced.

- ▶ Set temperature regulator to position 1 (position 35 in control box).
- ▶ Press and hold the burner state key and set the main switch in position I.

After pressing burner state key for at least 10 seconds, the appliance is in minimum flow position and the burner state key flashes.

- ▶ Open the hot water tap.
- ▶ Using the adjuster screw (Fig. 3, pos. 2) regulate the pressure to the values indicated in table 1.

		Natural gas H	But	Prop
Injector code	WT11	8708202116 (125)	8708202127 (74)	
	WT14	8708202124 (120)		
Connection pressure (mbar)	WT11	20	28	37
	WT14			
Burner pressure MAX (mbar)	WT11	10	26	34
	WT14			
Burner pressure min (mbar)	WT11	2	4	5
	WT14			

Table 1 Burner pressure

### 1.3 Performance optimization

With the new electronics there is no longer needed to perform optimization process.

### 1.4 Changing gas type

Use only authentic conversion kits. Conversion must only be carried out by an accredited technician. Authentic conversion kits are supplied with installation instructions.

- ▶ Close the gas valve.
- ▶ Disconnect the main switch and remove the front cover.
- ▶ Dismantle the burner.

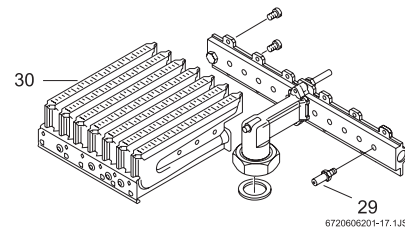

Fig. 4

## Gas regulation

- ▶ Dismantle both injectors groups and replace them.
- ▶ Reassemble the burner.
- ▶ Ensure there are no gas leaks.
- ▶ Open electronic cover.
- ▶ Set the jumper settings according to table 2.

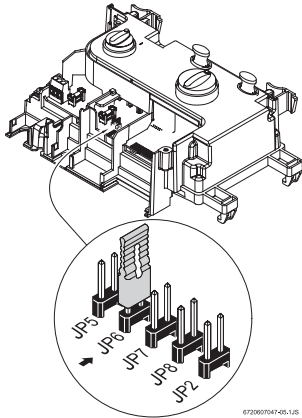

Fig. 5 Jumper (natural gas configuration)

- ▶ Take note of the new gas type in the appliance type plate.

JP6	Gas type
With jumper	Natural Gas
Without	LPG

Table 2 Gas type jumper configuration

### 1.5 Temperature range selection

Appliance temperature range is set to 35°C - 60°C. Placing jumper JP7, temperature range changes to 38°C - 50°C.

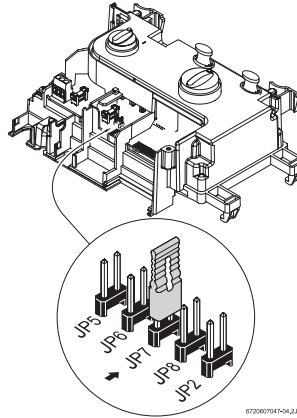

Fig. 6 Temperature range set

### 1.6 Start-up delay

Placing jumper JP2, the appliance will only ignite after 3 seconds of start-up water flow detection.

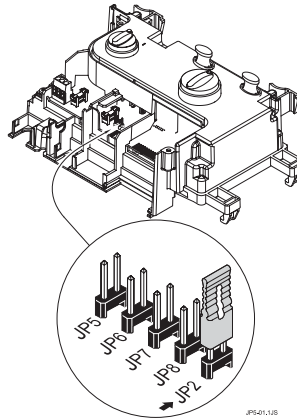

Fig. 7 Start-up delay

## Réglage du gaz

Avec cette nouvelle version de tableau électronique SAV, certains paragraphes de la notice d'installation de l'appareil doivent être modifiés.

Les nouveaux modes opératoires sont décrits ci-après.

## 1 Réglage du gaz

### 1.1 Réglage usine



Il est interdit de toucher aux organes scellés sauf dans le cas d'un changement de gaz effectué par un installateur agréé.

#### Gaz naturel

Les appareils destinés à être utilisés avec du gaz naturel (G 20/G25) sont fournis scellés après avoir été réglés en usine pour les valeurs indiquées sur la plaque signalétique.



Les appareils ne doivent pas être mis en service si la pression de raccordement est inférieure à 15 mbar ou supérieure à 25 mbar.

#### Gaz Butane/Propane

Les appareils destinés à être utilisés avec du gaz Butane/Propane (G30/G31) sont fournis scellés après avoir été réglés en usine pour les valeurs indiquées sur la plaque signalétique.



**Danger :** Les opérations décrites ci-dessous ne devront être effectuées que par un technicien qualifié.

Le réglage de la puissance se fait en ajustant la pression gaz du brûleur et nécessite pour cela un manomètre à tube en U.

### 1.2 Réglage de la pression

#### Accès à la vis de réglage

- ▶ Enlever l'habillage de l'appareil.
- ▶ Appuyer simultanément sur les languettes (A) et sortir le tableau électrique.

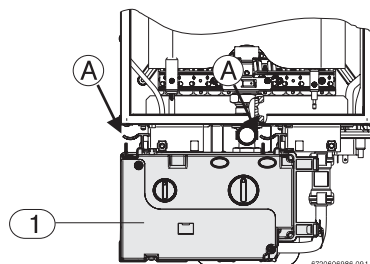

Fig. 1 Enlever le tableau électrique

- ▶ Une fois le tableau électrique retiré, positionnez-le conformément à la Fig. 2.

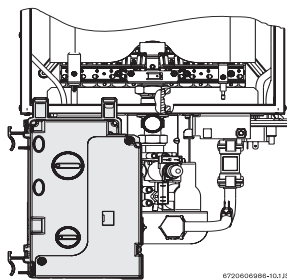

Fig. 2 Tableau électrique - position de réglage de gaz

#### Connexion du manomètre

- ▶ Desserrer la vis obturatrice (1).

## Réglage du gaz

- Connecter le manomètre au point de mesure de pression du brûleur.

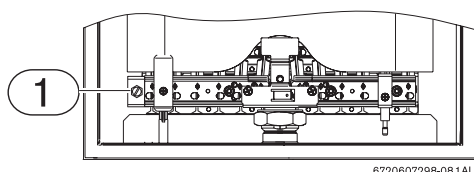

Fig. 3 Point de mesures de la pression du brûleur

- 1 Points de mesures de la pression du brûleur

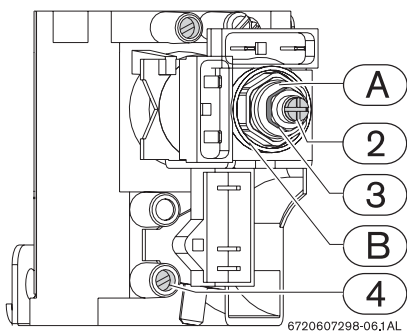

Fig. 4

- 2 Vis de réglage de débit gaz minimum  
3 Ecrou de blocage du régulateur  
4 Point de mesure de la pression du raccordement de gaz  
A Corps en laiton  
B Bague de blocage

### Réglage du débit gaz maximum (uniquement en cas de changement de bloc gaz)

- Sur le bloc gaz, à l'aide d'une clé plate, serrer l'écrou (rep.3) en butée sur le corps en laiton (A).



Durant cette opération, s'assurer que la bague de blocage rouge (B) ne tourne pas.

### Réglage du débit gaz minimum

Interrupteur principal en position 0.



Le réglage du débit gaz minimum est nécessaire seulement dans le cas où le brûleur s'éteint fréquemment quand la prise d'eau diminue.

- Placer le sélecteur de température en position 1.
- Appuyer sur la touche état du brûleur et, tout en la maintenant enfoncée, placer l'interrupteur principal sur la position On (1).

Après avoir appuyé pendant 10 secondes environ sur la touche d'état du brûleur, l'appareil se trouve en position de réglage de débit gaz minimum, la touche état du brûleur clignote.

- Ouvrir le robinet d'eau chaude.
- En utilisant la vis de réglage régler la pression jusqu'à atteindre les valeurs indiquées dans le tab. 1.

		Gaz naturel		But	Prop
Code de l'injecteur	LC10	8708202116 (125)		8708202127 (74)	
	LC13	8708202124 (120)			
Pression de raccordement (mbar)	LC10	20	25	28/30	37
	LC13				
Pression du brûleur MAX (mbar)	LC10	10	9,7	26	34
	LC13	11,5	10,4		36
Pression du brûleur MIN (mbar)	LC10	2	2,2	4	5
	LC13	2	2,2	3	4

Tab. 1 Pression du brûleur

## Réglage du gaz

### 1.3 Optimisation du rendement

Avec cette nouvelle électronique il n'y a plus besoin de procéder à l'optimisation du rendement.

### 1.4 Changement du type de gaz

Utiliser uniquement les kits de conversion d'origine. La conversion ne doit être effectuée que par un technicien agréé. Les kits de conversion d'origine sont fournis avec les instructions de montage.

- ▶ Fermer le robinet de gaz.
- ▶ Débrancher l'interrupteur principal de l'appareil et démonter la partie frontale.
- ▶ Démontez le brûleur.

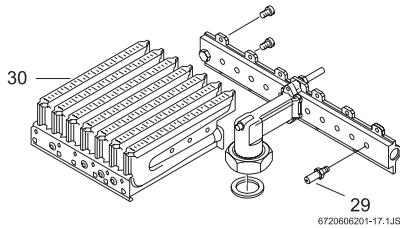

Fig. 5

- ▶ Démontez les deux rampes d'injecteurs et remplacez ces derniers.
- ▶ Installer le brûleur.
- ▶ Ouvrir le couvercle du tableau électrique.
- ▶ Configurer le tableau électrique à l'aide du cavalier si nécessaire (voir Tab. 2).

- ▶ Vérifier qu'il n'y ait pas de fuite de gaz.

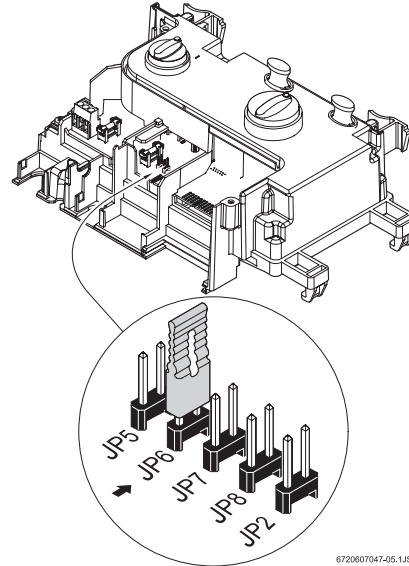

Fig. 6 Cavalier (sélection de la nature du gaz)

- ▶ Enregistrer le changement de type de gaz sur la plaque signalétique de l'appareil.

JP6	Type de gaz
With jumper	Gaz naturel
Without jum-	LPG

Tab. 2 Configuration de la nature de gaz avec le cavalier

## Réglage du gaz

### 1.5 Sélection de la plage de température

L'appareil est réglé de série sur une plage de température de 35°C à 60°C.

Si vous désirez modifier celle-ci:

- Insérer le cavalier sur "JP7" pour obtenir une plage de température de 38°C à 50°C.

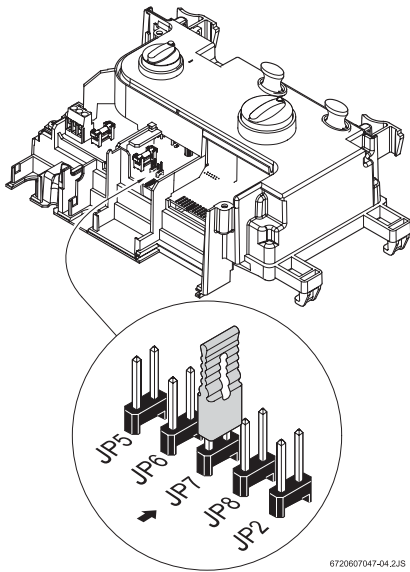

Fig. 7

### 1.6 Retardement de la prise en compte du signal de la turbine

Pour éviter un démarrage intempestif en cas de coup de bélier, insérer le cavalier en JP2 (l'appareil ne se mettra en route qu'au bout de 3 secondes de puisage).

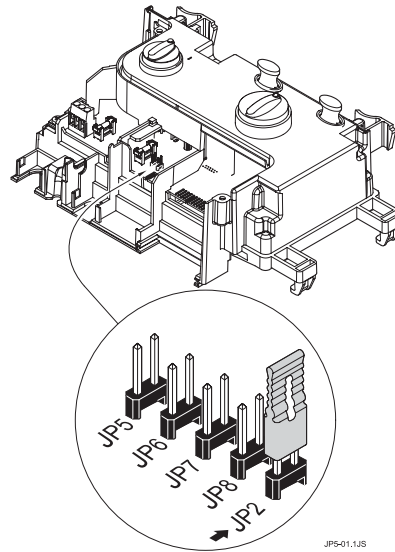

Fig. 8 Retardement de la prise en compte du signal de la turbine

Per via del nuovo circuito elettronico dell'apparecchio, alcune delle procedure, descritte nel libretto d'istruzioni per l'installazione, sono di conseguenza cambiate.

Di seguito, sono descritte le nuove procedure.

## 1 Regolazione del gas

### 1.1 Impostazioni di fabbrica



I componenti sigillati non devono essere manomessi o aperti.

#### Gas Metano

Gli apparecchi per gas Metano (G 20), dopo essere stati regolati in fabbrica per quei valori che compaiono nella targhetta delle caratteristiche, sono forniti con i componenti principali (interni) sigillati.



Gli apparecchi non devono essere messi in funzione se la pressione del gas Metano è minore di 15 mbar o superiore a 25 mbar.

#### Gas GPL

Gli apparecchi per gas GPL (Butano - G30 / Propano-G31) dopo essere stati regolati in fabbrica per quei valori che compaiono nella targhetta delle caratteristiche, sono forniti con i componenti principali (interni) sigillati.



**Pericolo:** le operazioni descritte in seguito devono essere eseguite da un tecnico abilitato ai sensi di legge.

E' possibile fare una regolazione e/o controllo ai fini della potenza nominale; per questa operazione è necessario un apposito manometro per gas.

### 1.2 Regolazione della pressione al bruciatore

#### Accesso ai componenti di regolazione

- Rimuovere il mantello dell'apparecchio.
- Premere contemporaneamente le due leve (A) ed estrarre in avanti il quadro comandi.

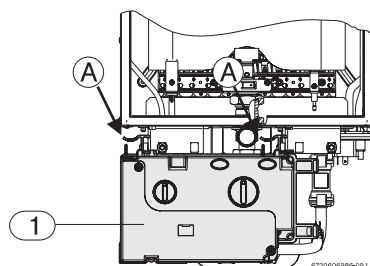

Fig. 1 Estrarre il quadro comandi

- Dopo l'estrazione del quadro comandi, agganciarlo come da Fig. 2.

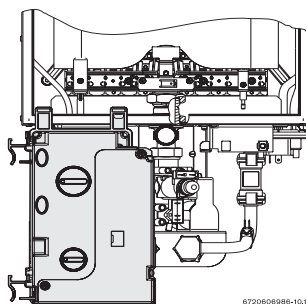

Fig. 2 Posizione d'aggancio del quadro comandi (accesso alle regolazioni gas)

#### Collegamento del manometro gas

- Svitare la vite posta internamente alla presa di pressione bruciatore (1) senza toglierla.

## Regolazione del gas

- ▶ Inserire il tubo del manometro gas sulla presa di pressione.

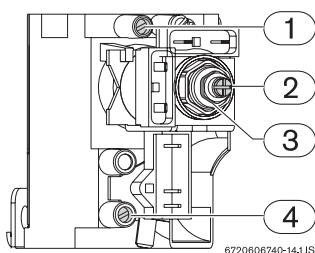

Fig. 3 Punti di controllo/regolazione gas

- 1 Presa per misurazione della pressione gas al bruciatore
- 2 Vite di regolazione pressione minima del gas
- 3 Dado di regolazione della pressione massima del gas
- 4 Presa per misurazione della pressione di rete del gas (Statica/Dinamica)

### Regolazione della pressione massima del gas

Interruttore principale nella posizione 0.

- ▶ Ruotare il selettore di temperatura nella posizione 6 (posizione 60 nel quadro comandi).
- ▶ Premere e mantener premuto, per almeno dieci secondi, la spia luminosa di "bruciatore acceso" (che funge anche da tasto per servizio tecnico (Fig. 7, pos.4) contemporaneamente ruotare l'interruttore principale in posizione I (Fig. 7, pos. 3).

L'apparecchio si trova ora in "posizione di regolazione" affinché possa essere controllata/regolata la pressione gas massima. La spia luminosa di "bruciatore acceso" lampeggia.

- ▶ Aprire un rubinetto dell'acqua calda.
- ▶ Con una chiave di misura corrispondente, ruotare il dado (Fig. 3, pos. 3). Regolare la pressione fino a raggiungere i valori indicati nella tabella 1.



Dopo aver eseguito regolazione, lasciar funzionare lo scaldabagno alla massima potenza per almeno 30 secondi.

### Regolazione della pressione minima del gas

Interruttore principale nella posizione 0.



La regolazione del minimo è necessaria solo se il bruciatore presenta frequenti spegnimenti quando si riduce la portata (quantità) dell'acqua ai rubinetti di prelievo.

- ▶ Ruotare il selettore di temperatura nella posizione 1 (posizione 35 nel quadro comandi).
- ▶ Premere e mantener premuto, per almeno dieci secondi, la spia luminosa di "bruciatore acceso" (che funge anche da tasto per servizio tecnico, contemporaneamente ruotare l'interruttore principale in posizione I.

L'apparecchio si trova ora in "posizione di regolazione" affinché possa essere controllata/regolata la pressione gas minima. La spia luminosa di "bruciatore acceso" lampeggia.

- ▶ Aprire il rubinetto dell'acqua calda.
- ▶ Tenere fermo il dado (Fig. 3, pos. 3) con una chiave di misura corrispondente
- ▶ Con un cacciavite **non magnetico** ruotare la vite (Fig. 3, pos. 2). Regolare la pressione fino a ottenere i valori indicati nella tabella 1.



## Regolazione del gas

		Gas Metano	But.	Prop.
Codice ugelli	WT11	8708202116 (125)	8708202127 (74)	
	WT14	8708202124 (120)		
Pressione di rete (mbar)	WT11	20	28	37
	WT14			
Pressione massima al bruciatore (mbar)	WT11	10	26	34
	WT14	13		36
Pressione minima al bruciatore (mbar)	WT11	2	4	5
	WT14	2	3	4

Tab. 1 Valori di pressione gas

### 1.3 Ottimizzazione delle prestazioni

Per via del nuovo circuito elettronico dell'apparecchio, non è più necessario eseguire il processo di ottimizzazione delle prestazioni.

### 1.4 Trasformazione gas

Utilizzare solo kit di trasformazione originali. L'intervento deve essere eseguito da un tecnico abilitato ai sensi di legge (L. 46/90) o da un Servizio di assistenza tecnica, autorizzato JUNKERS. I kit di trasformazione originali, sono forniti con le istruzioni per l'operazione di trasformazione gas.

- ▶ Chiudere i rubinetti gas ed acqua a monte dell'apparecchio.
- ▶ Disinserire la tensione 230V presso l'interruttore bipolare, a monte dell'apparecchio, presso l'interruttore principale e smontare il mantello.

- ▶ Smontare il bruciatore.

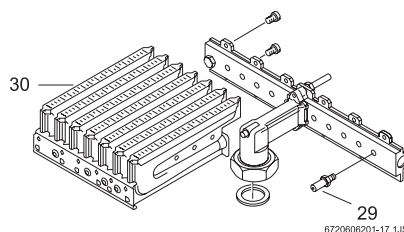

Fig. 4

- ▶ Smontare entrambe le rampe degli ugelli (Fig. 4, pos. 30) e sostituire gli ugelli (Fig. 4, pos. 29).
- ▶ Rimontare il bruciatore.
- ▶ Verificare che non ci siano fughe di gas.
- ▶ Togliere il coperchio del quadro comandi.
- ▶ Per impostare il tipo di combustibile utilizzato fare riferimento alla tabella 2, inserire il ponticello nei morsetti JP6 per un funzionamento con metano, togliere il ponticello dai morsetti JP6 per un funzionamento a GPL.

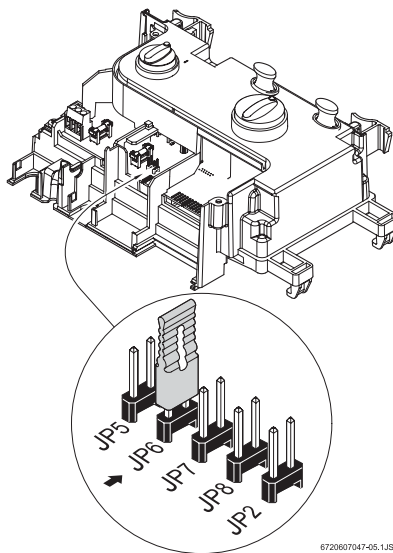

Fig. 5 Posizione morsetti e ponticello

## Regolazione del gas

- Registrare l'operazione di trasformazione gas, nella targhetta delle caratteristiche dell'apparecchio.

Morsetti JP6	Tipo di gas
Con ponticello	Metano
Senza ponticello	GPL

Tab. 2 Utilizzo del ponticello per configurazione gas

### 1.5 Opzioni modificabili mediante l'uso del ponticello

Lo scaldabagno è impostato di fabbrica con un campo di temperatura da 35°C a 60°C. Inserendo il ponticello nei morsetti JP7 il campo di temperatura viene impostato da 38°C a 50°C.

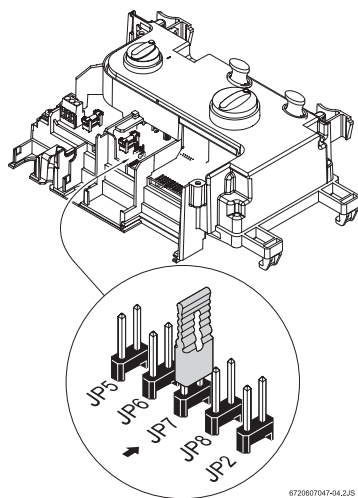

Fig. 6

### 1.6 Ritardo di accensione (da utilizzarsi in caso di colpi di ariete)

In impianti dove si presentano i fenomeni di colpi d'ariete è possibile ritardare l'accensione dello scaldabagno di 3 secondi.

Per attivare la funzione di ritardo accensione, inserire il ponticello sui morsetti JP2.

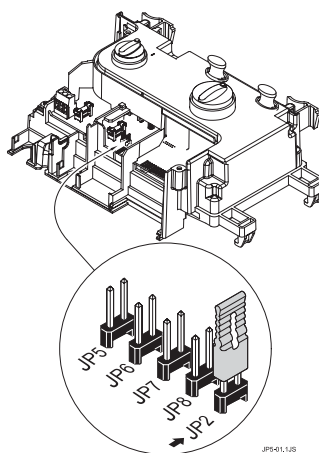

Fig. 7 Ritardo di accensione

## Ρύθμιση αερίου

Με την καινούργια πλακέτα, κάποιες ενέργειες που περιγράφονται στο εγχειρίδιο εγκατάστασης έχουν αλλάξει. Παρακάτω περιγράφονται οι αλλαγές που έχουν γίνει.

### 1 Ρύθμιση αερίου

#### 1.1 Εργοστασιακές ρυθμίσεις



Μην διενεργείτε καμία επέμβαση στα σφραγισμένα προ-ρυθμισμένα εξαρτήματα.

#### Φυσικό αέριο

Οι θερμοσίφωνες που προορίζονται για χρήση με φυσικό αέριο Η (G 20) έχουν ρυθμιστεί από το εργοστάσιο και παραδίδονται κατόπιν επισταμένου ελέγχου των τιμών που αναγράφονται στο φύλλο στοιχείων.



Δεν επιτρέπεται η ενεργοποίηση της λειτουργίας ανάφλεξης του θερμοσίφωνα, εάν η πίεση σύνδεσης είναι χαμηλότερη από 15 mbar και υψηλότερη από 25 mbar.

#### Υγραέριο

Οι θερμοσίφωνες προπανίου /βουτανίου (G31 /G30) έχουν ρυθμιστεί από το εργοστάσιο και παραδίδονται κατόπιν επισταμένου ελέγχου των τιμών που αναγράφονται στο φύλλο στοιχείων.



**Κίνδυνος:** Οι ακόλουθες ενέργειες πρέπει να εκτελούνται από εξειδικευμένο τεχνικό.

Η ισχύς προσαρμόζεται σύμφωνα με τη διαδικασία ρύθμισης πίεσης καυστήρα, όπου για τον σκοπό αυτό απαιτείται μανόμετρο με σωλήνες σύνδεσης σχήματος U.

#### 1.2 Ρύθμιση πίεσης

##### Πρόσβαση στον ρυθμιστικό κοχλία

- ▶ Αφαιρέστε το εμπρόσθιο κάλυμμα της συσκευής.
- ▶ Πιέστε ταυτόχρονα τις δύο γλωττίδες (A) και τραβήξτε τον πίνακα ελέγχου.

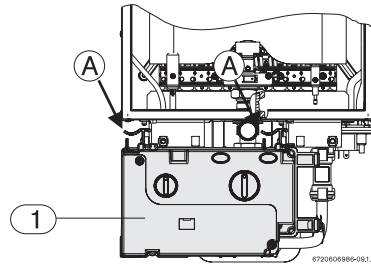

εικόνα 1 Αφαιρέστε τον πίνακα ελέγχου

- ▶ Αφού αφαιρέσετε τον πίνακα ελέγχου, τοποθετήστε το όπως υποδεικνύεται στην εικ. 2.

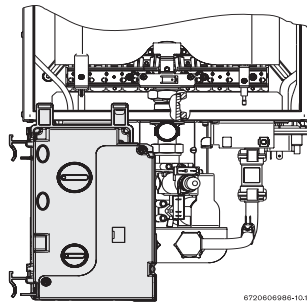

εικόνα 2 Πίνακας ελέγχου – Θέση ρύθμισης αερίου

##### Σύνδεση μανόμετρου

- ▶ Χαλαρώστε την βίδα σφράγισης (1).

## Ρύθμιση αερίου

- Συνδέστε το μανόμετρο με τον σωλήνα σχήματος U στο σημείο μέτρησης πίεσης καυστήρα.

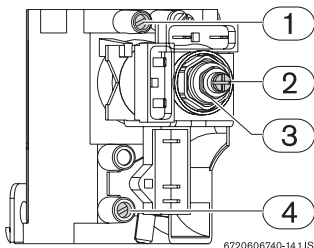

εικόνα 3 Σημεία μέτρησης πίεσης

- 1 Σημείο μέτρησης πίεσης καυστήρα
- 2 Ρυθμιστική βίδα ελάχιστης ροής αερίου
- 3 Ρυθμιστής μέγιστης ροής αερίου
- 4 Σημείο μέτρησης πίεσης παροχής αερίου

### Ρύθμιση μέγιστης ροής αερίου

Ο κύριος διακόπτης βρίσκεται στη θέση 0.

- Θέστε τον ρυθμιστή θερμοκρασίας στους 60°C.
- Πιέστε και κρατήστε το κουμπί κατάστασης καυστήρα και θέστε τον κύριο διακόπτη στη θέση I.

Αφού κρατήσετε πατημένο το κουμπί ένδειξης λειτουργίας καυστήρα για τουλάχιστον 10 δευτερόλεπτα, η συσκευή βρίσκεται στη θέση μέγιστης ροής και το κουμπί κατάστασης καυστήρα αναβοσβήνει.

- Ανοίξτε τη στρόφιγγα ζεστού νερού.
- Χρησιμοποιώντας τον ρυθμιστή (Εικ. 3, θέση 3) ρυθμίστε την πίεση, ώστε να επιτευχθεί η τιμή που υποδεικνύεται στον πίνακα 1.



Μετά την ρύθμιση, αφήστε την συσκευή να λειτουργήσει, σε max ισχύ, για τουλάχιστον 30 δευτερόλεπτα.

### Ρύθμιση ελάχιστης ροής αερίου

Ο κύριος διακόπτης βρίσκεται στη θέση 0.



Η ρύθμιση ελάχιστης ροής είναι απαραίτητη μόνο εάν ο καυστήρας απενεργοποιείται συχνά, όταν η ροή νερού μειώνεται.

- Θέστε τον ρυθμιστή θερμοκρασίας στους 35°C.
- Πιέστε και κρατήστε το κουμπί κατάστασης καυστήρα και θέστε τον κύριο διακόπτη στη θέση I.

Αφού κρατήσετε πατημένο το κουμπί ένδειξης λειτουργίας καυστήρα για τουλάχιστον 10 δευτερόλεπτα, η συσκευή βρίσκεται στη θέση ελάχιστης ροής και το κουμπί κατάστασης καυστήρα αναβοσβήνει.

- Ανοίξτε τη στρόφιγγα ζεστού νερού.
- Χρησιμοποιώντας την ρυθμιστική βίδα (Εικ. 3, θέση 2) ρυθμίστε την πίεση σύμφωνα με τις τιμές που αναφέρονται στον πίνακα 1.

		Φυσικό αέριο H	Βουτά-νιο	Προπάνιο
Κωδικός ακροφύσιων	WT11	8708202116 (125)	8708202127 (74)	
	WT14	8708202124 (120)		
Πίεση σύνδεσης (mbar)	WT11	20	28	37
	WT14			
Μέγιστη πίεση καυστήρα (mbar)	WT11	10	26	34
	WT14			
Ελάχιστη πίεση καυστήρα (mbar)	WT11	2	4	5
	WT14			

πίνακας 1

Πίεση καυστήρα

## Ρύθμιση αερίου

### 1.3 Βελτιστοποίηση απόδοσης

Με την καινούργια πλακέτα δεν χρειάζεται πλέον να διενεργηθεί η διαδικασία βελτιστοποίησης της απόδοσης.

### 1.4 Αλλαγή τύπου αερίου

Χρησιμοποιήστε μόνο αυθεντικά σετ μετατροπής. Η μετατροπή πρέπει να διενεργείται μόνο από εξουσιοδοτημένο τεχνικό. Τα αυθεντικά σετ μετατροπής συνοδεύονται από οδηγίες εγκατάστασης.

- ▶ Κλείστε τη βαλβίδα αερίου.
- ▶ Αποσυνδέστε τον κύριο διακόπτη και αφαιρέστε το εμπρόσθιο κάλυμμα.
- ▶ Αποσυναρμολογήστε τον καυστήρα.

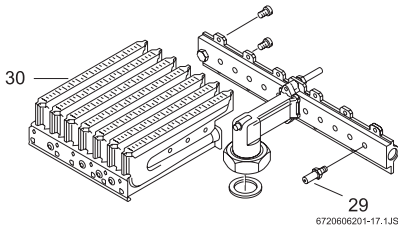

εικόνα 4

- ▶ Αποσυναρμολογήστε και τα δύο συγκροτήματα ακροφύσιων και αντικαταστήστε τα.
- ▶ Συναρμολογήστε πάλι τον καυστήρα.
- ▶ Βεβαιωθείτε ότι δεν υπάρχουν διαρροές αερίου.
- ▶ Ανοίξτε το καπάκι της πλακέτας.

- ▶ Τοποθετήστε την γέφυρα σύμφωνα με τον πίνακα 2.

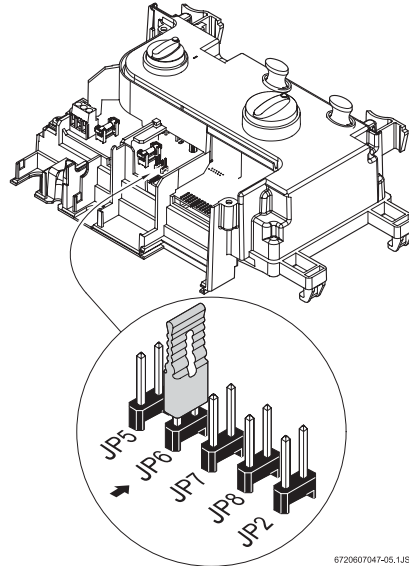

εικόνα 5 Γέφυρα (θέση για υγραέριο)

JP6	Τύπος αερίου
Με γέφυρα	Φυσικό αέριο
Χωρίς	Υγραέριο

πίνακας 2 Προδιαγραφές τύπου αερίου

## Ρύθμιση αερίου

### 1.5 Επιπλέον ρύθμιση

Το εύρος θερμοκρασίας της συσκευής είναι ρυθμισμένο μεταξύ 35°C - 60°C. Βάζοντας τη γέφυρα στη θέση JP7, το εύρος θερμοκρασίας μεταβάλλεται μεταξύ 38°C - 50°C.

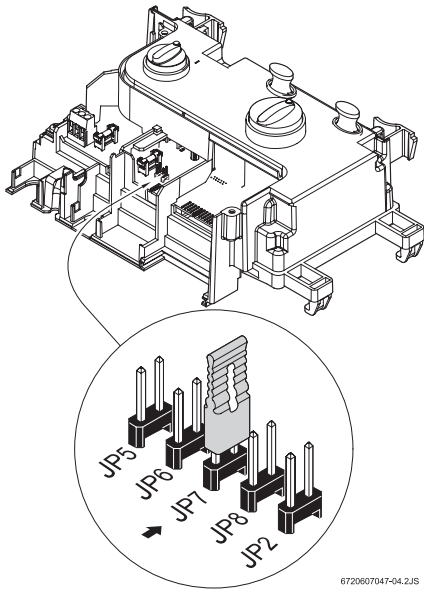

εικόνα 6

6720607047-04.2.JS

### 1.6 Χρονική υστέρηση εκκίνησης

Τοποθετώντας την γέφυρα JP2, η συσκευή θα ξεκινήσει την διαδικασία εκκίνησης, 3 δευτερόλεπτα μετά το άνοιγμα κάποιας παροχής νερού.

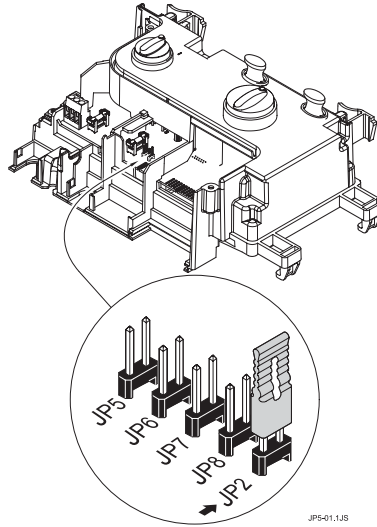

εικόνα 7 Χρονική υστέρηση εκκίνησης

JP5-01.1.JS

## Gasregeling

Vanwege de nieuwe elektronica, zijn er een aantal handelingen - die beschreven zijn in de installatie-instructie - gewijzigd. Hieronder is de gewijzigde procedure omschreven.

## 1 Gasregeling

### 1.1 Fabrieksinstellingen



Verzegelde onderdelen mogen niet gewijzigd worden.

#### Aardgas

Geisers die ontworpen zijn voor aardgas L (G25) worden in de fabriek verzegeld voor de levering nadat de waarden op het typeplaatje zijn gecontroleerd.



Geisers mogen niet ontstoken worden wanneer de gasvoordruk minder is dan 20 mbar en meer dan 30 mbar is.

#### Vloeibaar gas

Geisers op propaan/butaan (G31) dienen ter plaatse te worden omgebouwd. Maak hierbij gebruik van de beschikbare ombouwsets.



**Gevaar:** De volgende handelingen moeten uitgevoerd worden door een erkend installateur.

Het vermogen dient te worden afgesteld volgens. Gebruik hiervoor een digitale drukketer.

### 1.2 Gasdrukafstelling

#### Verwijderen van de besturingsunit

- ▶ Verwijder het voorpaneel van het toestel.

- ▶ Druk gelijktijdig op beide lipjes (A) en trek aan de besturingsunit.

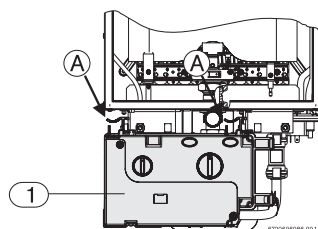

Afb. 1 Verwijderen van de besturingsunit

- ▶ Draai de besturingsunit een kwartslag.
- ▶ Hang de besturingskast aan de daarvoor bestemde haken op.

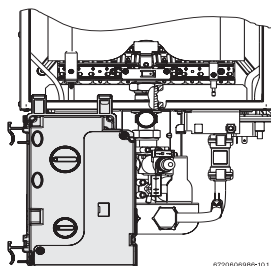

Afb. 2 besturingsunit - gasblok

#### Aansluiten drukketer

- ▶ Draai de branderdrukmeetnippel (1) los.
- ▶ Sluit de digitale drukketer aan op de branderdrukmeetnippel.

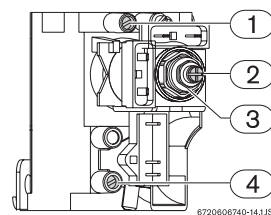

Afb. 3 Drukmeetpunten

- |   |   |
|---|---|
| 1 | Branderdrukmeetnippel                   |
| 2 | Stelschroef minimale gasdruk (laaglast) |
| 3 | Stelmoer maximale gasdruk (volland)     |
| 4 | Gasvoordrukmeetnippel                   |

## Gasregeling

### Maximale gasdrukinstelling (vollast)

Hoofdschakelaar in positie 0.

- ▶ Stel de temperatuurregelaar in op 60°C.
- ▶ Houd de branderstatus-LED ingedrukt en zet de hoofdschakelaar in positie I.

Nadat de branderstatusstoets voor tenminste 10 seconden ingedrukt is geweest, brandt het toestel in vollast-bedrijf, de branderstatus-LED knippert.

- ▶ Open de warmwaterkraan.
- ▶ Gebruik de stelmoer om de druk te regelen voor het bereiken van de waarden die staan aangegeven in tabel 1.



Na het afstellen, het toestel tenminste 30 seconden op vollast laten draaien.

### Minimale gasdebietregeling

Hoofdschakelaar in positie 0.



De minimale gasdrukinstelling (laaglast) is alleen nodig als de brander vaak uitgaat wanneer het waterdebiet verminderd wordt.

- ▶ Stel de temperatuurregelaar in op 35°C.
- ▶ Houd de branderstatus-LED ingedrukt en zet de hoofdschakelaar in positie I.

Nadat de branderstatusstoets voor tenminste 10 seconden ingedrukt is geweest, brandt het toestel op laaglast-bedrijf en de branderstatus-LED knippert.

- ▶ Open de warmwaterkraan.
- ▶ Gebruik de stelschroef (Afb. 3, pos. 2) om de druk in te stellen op de waarden die staan aangegeven in Tabel 1.

		Aardgas	Prop
Artikelnummer gasinspuiters	WT10/ F2500	8708202147 (130)	8708202127 (74)
	WT13/ F3300	8708202114 (140)	
gasvoordruk (mbar)	WT10/ F2500 WT13/ F3300	25	29/50
Branderdruk max (mbar)	WT10/ F2500	11,5	34
	WT13/ F3300	10,0	36
Branderdruk min (mbar)	WT10/ F2500	1,8	5
	WT13/ F3300	1,8	4

Tabel 1 Branderdruk

### 1.3 Optimalisatie

Vanwege de nieuwe elektronica is een toesteloptimalisatie niet meer nodig.

### 1.4 Ombouw naar een andere gassoort

Gebruik alleen originele onderdelen. Het ombouwen mag alleen worden uitgevoerd door de erkende installateur. Originele onderdelen worden geleverd met installatie-instructie.

- ▶ Sluit de gasklep.
- ▶ Zet de hoofdschakelaar uit en verwijder de afdekplaat.
- ▶ Demonteer de brander.

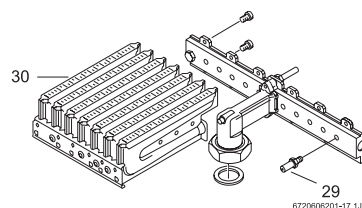

Afb. 4

- ▶ Demonteer beide injectorgroepen en vervang deze.
- ▶ Zet de brander weer in elkaar.



- ▶ Controleer de koppelingen op gaslekkage.
- ▶ Open de afdekkap van de elektronica.
- ▶ Stel de jumper in zoals aangegeven in tabel 2.

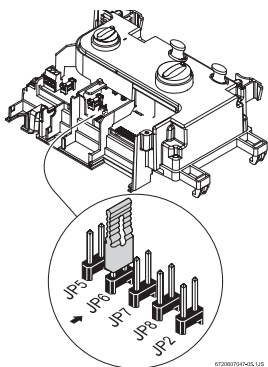

Afb. 5 Jumper (aardgas configuratie)

- ▶ Vermeld de gastypewijziging op het typeplaatje van het toestel.

JP6	Gassoort
met jumper	aardgas
zonder jumper	LPG

Tabel 2 jumper configuratie voor gassoort

### 1.5 Jumper opties

Toesteltemperatuurbereik is ingesteld op 35°C - 60°C. Door de jumper JP7 te plaatsen, verandert het temperatuurbereik naar 38°C - 50°C.

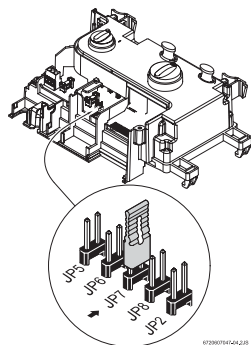

Afb. 6 jumper opties

### 1.6 Tapdrempel

Door de jumper JP8 te plaatsen, wordt de tapdrempel verlaagd naar 2,5 l/min.

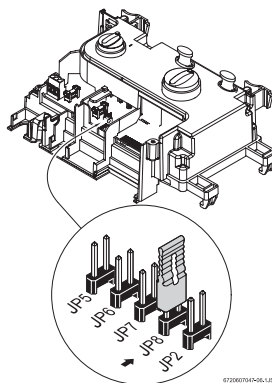

Afb. 7

### 1.7 Ontstekings vertraging

Bij het plaatsen van de jumper op positie JP2, zal de geiser 3 seconden na flow detectie ontsteken.

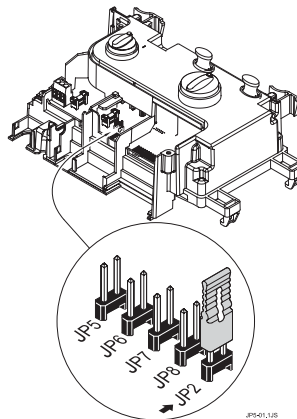

Afb. 8 Ontstekings vertraging

## Gaz Ayarı

Elektronik kart veya kumanda ünitesinin değişiminde montaj kılavuzundan farklı olarak aşağıdaki prosedürler dikkate alınmalıdır.

### 1 Gaz Ayarı

#### 1.1 Fabrika Ayarı



Mühürlü parçalara kesinlikle müdahale edilmemelidir.

#### Doğalgaz

Doğalgaz (H Grubu, G20) için dizayn edilmiş cihazlar, sicil plaketindeki değerlere göre kontrol edildikten sonra, fabrika çıkışında mühürlenmiştir.



Gaz giriş basıncının 15 mbar' ın altında veya 25 mbar' ın üzerinde olması halinde, cihaz işletmeye alınmamalıdır!

#### LPG (Tüpgaz)

LPG (Tüpgaz) cihazları, sicil plaketindeki değerlere göre kontrol edildikten sonra, fabrika çıkışında mühürlenmiştir.



**Tehlike:** Aşağıdaki operasyonlar, yalnızca yetkili servis tarafından yürütülmelidir.

Cihazın gücü, brülör basıncı ölçüm prosesiyle tespit edilebilir. Bu ölçüm için kesinlikle bir U manometre gereklidir.

#### 1.2 Gaz Basıncı Ayarı

##### Ayar Vidasına Erişim

- Cihazın dış mantosunu çıkartın.

- Her iki tespit kulağına (A) aynı anda basın ve kontrol kutusunu çekerek yerinden çıkartın.

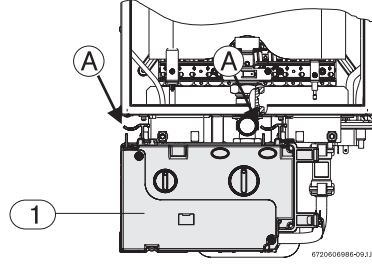

Res. 1 Kontrol kutusunun çıkartılması

- Kontrol kutusunu, Resim 2' de görüldüğü gibi servis pozisyonuna alın.

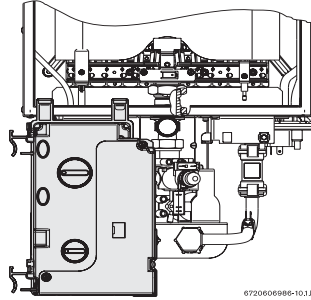

Res. 2 Kontrol Kutusu – Gaz ayar pozisyonu

##### U-Manometresinin Bağlanması

- Manometre bağlantı ağzındaki vidayı gevşeltin (1).
- Brülör gaz basıncı ölçüm ağzına U-Manometresi hortumunu takın.

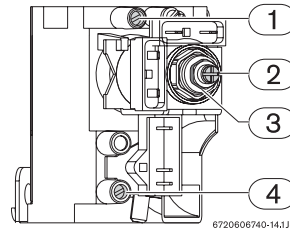

Res. 3 Gaz basıncı ölçüm ağızları

## Gaz Ayarı

- 1 Brülör gaz basıncı ölçüm ağızı
- 2 Min. gaz basıncı ayar vidası
- 3 Min. gaz basıncı ayar somunu
- 4 Gaz giriş basıncı ölçüm ağızı

### Max. Gaz Basıncı Ayarı

ON/OFF şalterini (0) konumuna getirin.

- ▶ Sıcaklık ayar düğmesini 60 °C'a (Poz. 6) ayarlayın.
- ▶ Brülör işletme LED' ine basın ve ON/OFF şalterini (I) konumuna getirin.

Cihaz max. konumuna geçer ve brülör işletme LED' i (yeşil) yanıp sönmeye başlar.

- ▶ Sıcak su musluğunu açın.
- ▶ Max. gaz ayar somunu (Resim 3, Poz. 3) yardımıyla vede Tablo 1'e göre gaz ayarı yapın.



Gaz ayarını tamamladıktan sonra cihazı max. konumda 30 saniye çalıştırın.

### Min. Gaz Basıncı Ayarı

ON/OFF şalterini (0) konumuna getirin.



Min. gaz basıncı ayarı : su debisi azaltıldığında brülör sık sık sönüyor ise gerekli olacaktır.

- ▶ Sıcaklık ayar düğmesini 35 °C'a (Poz. 1) ayarlayın.
- ▶ Brülör işletme LED' ine basın ve ON/OFF şalterini (I) konumuna getirin..

Cihaz min. konumuna geçer ve brülör işletme LED' i (yeşil) yanıp sönmeye başlar.

- ▶ Sıcak su musluğunu açın.
- ▶ Min. gaz ayar vidası (Resim 3, Poz. 2) yardımıyla vede Tablo 1'e göre gaz ayarı yapın.

		Doğalgaz (H Grubu)	Büt.	Prop.
Enjektör Memesi kodu	RDT 14.. (WT14)	8708202124 (120)	8708202127 (74)	
Gaz Giriş Basıncı (mbar)	RDT 14.. (WT14)	20	28	37
Brülör Basıncı Max (mbar)	RDT 14.. (WT14)	13	26	36
Brülör Basıncı Min (mbar)	RDT 14.. (WT14)	2	3	4

Tab. 3 Brülör Gaz Basınçları

### 1.3 Performans optimazasyonu

Yeni kumanda ünitesi ile performans optimazasyonuna gerek yoktur

### 1.4 Gaz Dönüşümü

Dönüşümde, yalnızca orijinal dönüşüm kitleri kullanılmalı ve gaz dönüşüm işlemi, yalnızca yetkili servis tarafından yapılmalıdır. Aksine hareket halinde ortaya çıkabilecek muhtemel uygunsuzluklardan vede hasarlardan sorumluluk kabul edilmez.

- ▶ Gaz vanasını kapatın.
- ▶ ON/OFF şalterini kapatın ve cihazın dış mantosunu çıkartın.
- ▶ Brülörü sökün.

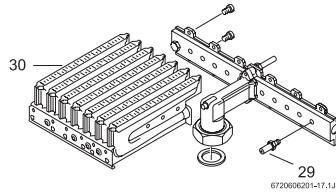

Res. 4

- ▶ Her iki brülör grubunu sökün ve gaz kolektörü üzerindeki enjektör memelerini sökün.

## Gaz Ayarı

- Tersine hareket ederek brülörü toplayın ve yerine takın.
- Gaz sızdırmazlık kontrolü yapın.
- Kumanda ünitesi kapağını açın.
- Tablo 2' ye göre jumper ayarlarını yapın.

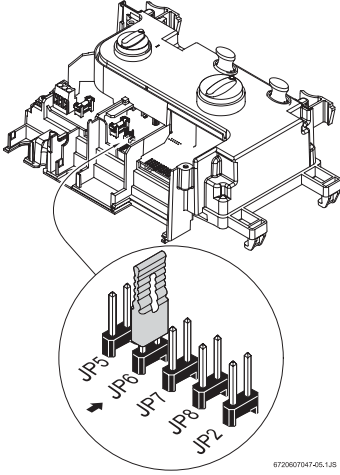

Res. 5 Jumper (Doğalgaz konfigürasyonu)

- Gaz tipi değişikliğini, cihaz sicil plaketi üzerinde, kalıcı bir şekilde işaretleyin.

JP6	Gaz Cinsi
Jumper takılı	Doğalgaz
Jumper takılı değil	LPG

Tab. 4 Gaz cinsine göre Jumper konfigürasyonu

### 1.5 Sıcaklık Aralığı Seçimi

Cihazın sıcaklık aralığı 35 - 60 °C olarak ayarlanmıştır. Jumper' in JP7 'ye alarak sıcaklık aralığını 38 - 50 °C olarak değiştirilebilir.

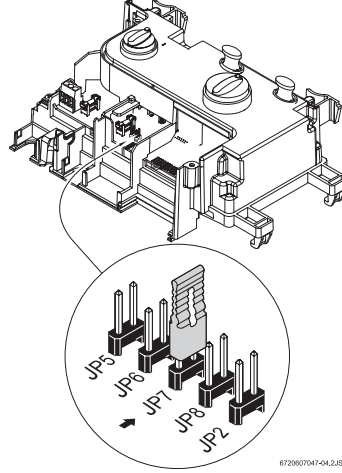

Res. 6 Sıcaklık Aralık Ayarı

### 1.6 Sıcak Kullanım Suyu Talebi Algılanma Zamanının Geciktirilmesi Ayarı

Jmper 2' nin takılmasıyla, cihaz kullanım suyu talebi olduğunda 3 saniye sonra gecikmeli olarak ateşleme yapar (devreye girer).

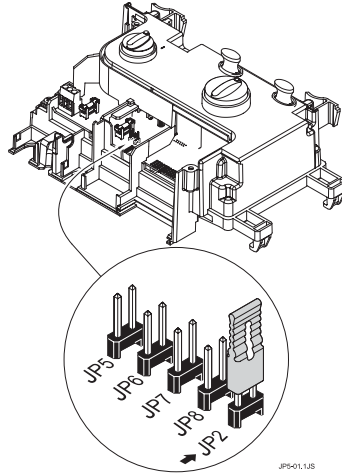

Res. 7 Cihaz Baslangicinin Geciktirilmesi