

PSW 750-5, 1000-5 S-solar

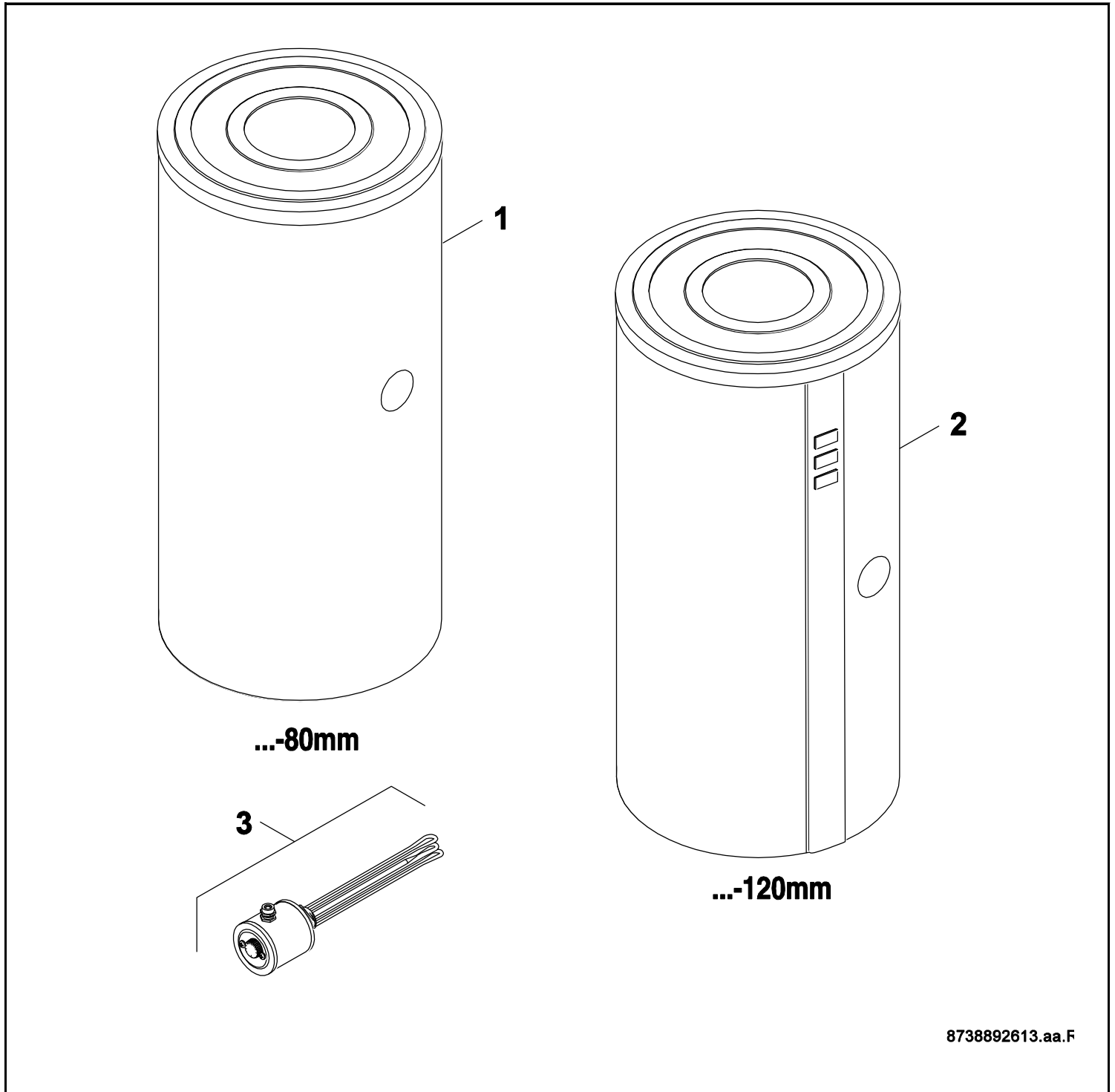

8738892613.aa.F



[de] Wichtige Hinweise zur Installation/Montage

Die Installation/Montage muss durch eine für die Arbeiten zugelassene Fachkraft unter Beachtung der geltenden Vorschriften erfolgen.

[en] Important notes on installation/assembly

The installation/assembly must be carried out by a professional who is authorised to do the work, and with due regard to the relevant regulations.

[fr] Instructions importantes pour l'installation/le montage

L'installation/le montage doit être effectué(e) par un spécialiste qualifié pour les opérations concernées et dans le respect des prescriptions applicables.

[bg] Важни указания във връзка с инсталацията/монтажа

Инсталацията/монтажът трябва да се извършва от лицензиран за работите специалист в съответствие с приложимите разпоредби.

[cs] Důležité pokyny k instalaci/montáži

Instalaci/montáž musí při dodržení platných předpisů provést odborný pracovník s příslušným oprávněním pro tyto práce.

[da] Vigtige anvisninger til installationen/monteringen

Installationen/monteringen skal foretages af en godkendt installatør under overholdelse af de gældende forskrifter.

[el] Σημαντικές υποδείξεις για την εγκατάσταση/συναρμολόγηση

Η εγκατάσταση/συναρμολόγηση πρέπει να πραγματοποιείται από εξουσιοδοτημένο για τις εργασίες αυτές τεχνικό προσωπικό, το οποίο θα πρέπει να φροντίζει ώστε να τηρούνται οι ισχύουσες διατάξεις.

[es] Indicaciones importantes para instalación/montaje

La instalación/el montaje lo debe realizar personal especializado autorizado para los trabajos, respetando las prescripciones vigentes.

[et] Olulised juhised paigaldamiseks/montaažiks

Paigaldamist/montaaži tohib läbi viia selleks volitusi omav spetsialist, arvestades kehtivaid nõudeid.

[fi] Belangrijke aanwijzingen betreffende de installatie/montage

De installatie/montage moet worden uitgevoerd door een voor de werkzaamheden geautoriseerde installateur. Hij moet rekening houden met de geldende voorschriften.

[fi] Tärkeitä asennus- ja kokoonpano-ohjeita

Näihin töihin hyväksytyn ammattiasentajan pitää suorittaa asennus- ja kokoonpanotyöt voimassa olevien määräysten mukaisesti.

[hu] Fontos tudnivalók az installálás/szereléshez

Az installálás/szerelést egy, a munkákra felhatalmazott szakembernek kell végeznie, az érvényes előírások figyelembevételével.

[it] Avvertenze importanti per l'installazione/il montaggio

L'installazione/il montaggio deve aver luogo ad opera di una ditta specializzata ed autorizzata in osservanza delle disposizioni vigenti.

[he] מניפולציות/מонтаזים חשובות לנציבים/מנציבים/מנציבים

נציבים/מנציבים/מנציבים חייבים להשתמש במומחים מוסמכים לביצוע עבודות אלו. יש להקפיד על כללי הבטיחות הנוגעים לעבודה זו.

[lt] Svarbios instaliavimo ir (arba) montavimo nuorodos

Instaliuoti ir montuoti, laikantis galiojančių taisyklių, leidžiama kvalifikuotiems specialistams, kurie buvo įgalioti šioms darbams atlikti.

[lv] Svarīgi norādījumi par iekārtas uzstādīšanu / montāžu

Iekārtas uzstādīšanu/montāžu ir jāveic specializētam sertificētam speciālistam, ievērojot spēkā esošos noteikumus.

[nl] Belangrijke aanwijzingen betreffende de installatie/montage

De installatie/montage moet worden uitgevoerd door een voor de werkzaamheden geautoriseerde installateur rekening houdend met de geldende voorschriften.

[no] Viktig informasjon om installasjon/montering

Installasjonen/monteringen skal gjennomføres av autoriserte installatører, og gjeldende forskrifter skal følges.

[pl] Ważne wskazówki dotyczące instalacji/montażu

Instalacja /montaż muszą być wykonane przez uprawnionego do tego rodzaju prac specjalistę przy zachowaniu obowiązujących przepisów.

[pt] Indicações importantes relativas à instalação/montagem

A instalação/montagem deve ser efetuada por um técnico especializado com qualificações para estes trabalhos, tendo em atenção os regulamentos em vigor.

[ro] Indicații importante privind instalarea/montajul

Instalarea/montajul trebuie realizate de către un specialist autorizat pentru lucrările respective, respectându-se prescripțiile valabile.

[ru] Важные указания по подключению/монтажу

Подключение/монтаж должны выполнять специалисты, имеющие допуск к выполнению таких работ, при соблюдении действующих норм и правил.

[sk] Dôležité pokyny týkajúce sa inštalácie/montáže

Inštaláciu/montáž musí realizovať odborník s oprávnením na výkon týchto prác, pričom musí dodržiavať platné predpisy.

[sl] Pomembni napotki za namestitvev/montažo

Namestitvev/montažo mora izvesti strokovnjak, pristojen za tovrstna dela, ob upošte vanju veljavnih predpisov.

[sr] Važna uputstva za ugradnju i montažu

Ugradnju i montažu moraju da obave samo stručna lica ovlašćena za izvođenje takvih radova koja će poštovati važeće propise.

[sv] Viktiga anvisningar för installation/montering

Installationen/monteringen måste utföras av en behörig och fackkunnig person enligt gällande föreskrifter.

[tr] Kurulum/Montaj ile ilgili önemli uyarılar

Kurulum/Montaj çalışmaları sadece yetkili bayiler tarafından aşağıda belirtilen talimatlar dikkate alınarak yapılmalıdır.

[uk] Важливі вказівки щодо установки/монтажу

Установку/монтаж мають здійснювати фахівці, що мають дозвіл на проведення цих робіт, із дотримання чинних приписів.

[zh] 安装方面的重要提示

必须由受到许可承担该项工作的专业人员遵照相关法规进行安装。

[ar] ملاحظات هامة للتجميع

يجب أن يتم التجميع من قبل متخصص مصرح له بالعمل، مع مراعاة اللوائح السارية.

[fa] تذکرات مهم درباره نصب/مونتاژ

نصب/مونتاژ باید توسط فردی حرفه ای که مجاز به انجام این کار است، و همچنین با توجه کامل به مقررات مربوطه انجام شود.

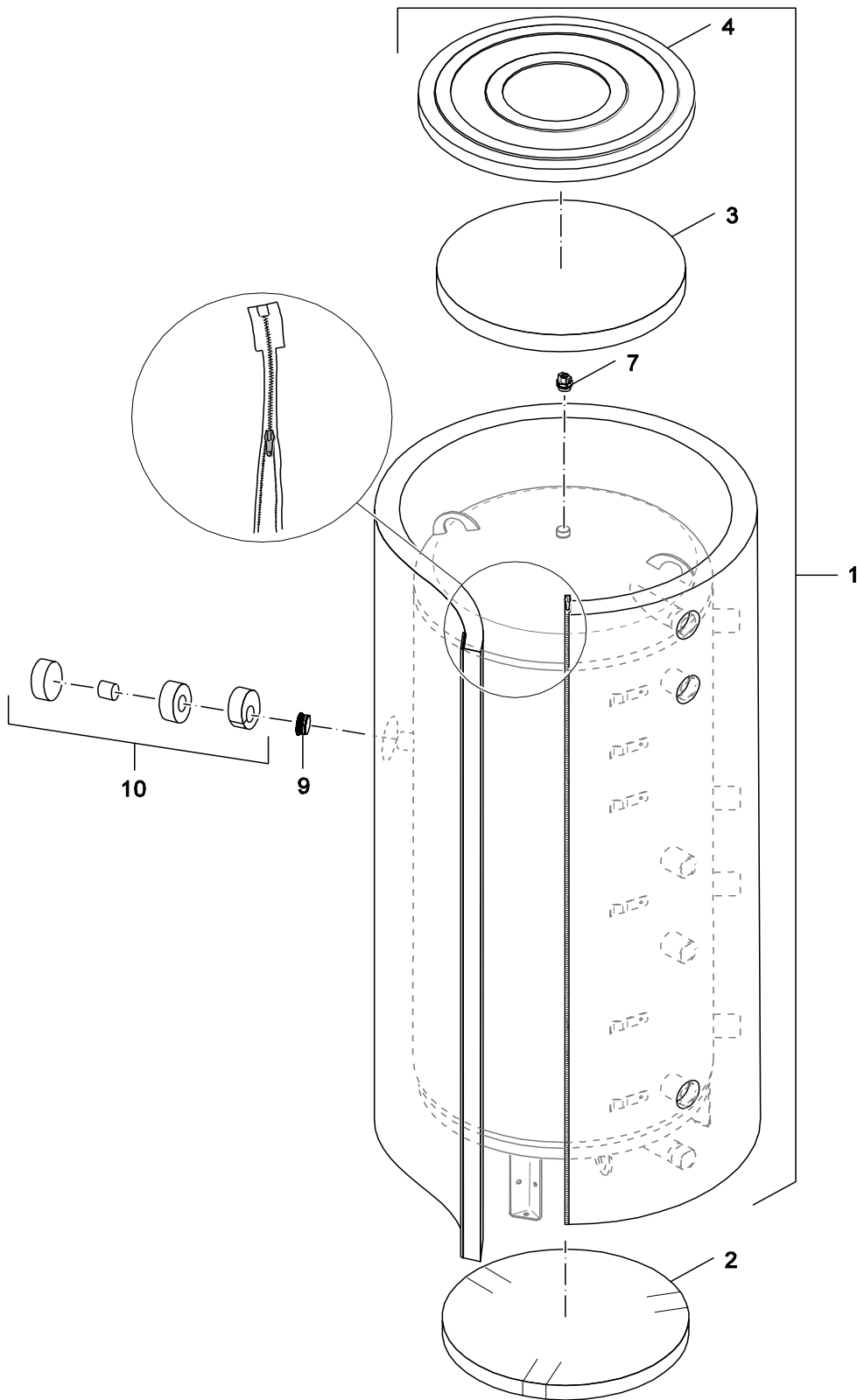

8738892599.aa.F

PSW 750-5, 1000-5 S-solar

1

- Pufferspeicher 500 - 1000L 80mm
- Buffer cylinder 500 - 1000L 80mm
- Ballon tampon 500 - 1000L 80mm
- Accumulatore puffer 500 - 1000L 80mm
- Bufferboiler 500 - 1000L 80mm
- Acumulador auxiliar 500 - 1000L 80mm

Pos	Bezeichnung Description Dénomination Descrizioni Benaming Descripción	Bestell-Nr. Ordering no. Numéro de commande N° d'ordine Bestelnummer Número el ordenar	PG												Bemerkungen Remarks Remarques Osservazioni Opmerkingen Observaciones			
				PSW 750/80-5 S-solar	PSW 750-5 S-solar	PSW 1000/80-5 S-solar	PSW 1000-5 S-solar											
1	Wärmesch Puffersp 750-5 80V Bo/Ju	8 735 100 074		■	■													
1	Wärmesch Puffersp 1000-5 80V Bo/Ju	8 735 100 075				■	■											
2	Isolierung Boden D790x80V	8 735 100 077		■	■	■	■											
3	Isolierung Deckel 750/1000-80V	8 735 100 079		■	■	■	■											
4	Deckel 750/1000-80 silber	8 718 573 224 0	33	■	■	■	■											
7	Entlüftungsventil 1/2"	8 718 221 694 0	14	■	■	■	■											
9	Stopfen G1 1/2" mit PTFE-Ring	63004276	22	■	■	■	■											
10	Abdeckung E-Heizung silber	8 718 573 222 0	26	■	■	■	■											
	Logo Junkers	8 711 145 928 0	16	■	■	■	■											
	Kabel Adapter WP ext. Umschaltventil	8 738 204 926				■	■											
PSW 750-5, 1000-5 S-solar				Pufferspeicher 500 - 1000L 80mm Buffer cylinder 500 - 1000L 80mm Ballon tampon 500 - 1000L 80mm Accumulatore puffer 500 - 1000L 80mm Bufferboiler 500 - 1000L 80mm Acumulador auxiliar 500 - 1000L 80mm											1			

Ersatzteilliste
Spare parts list

Liste des pièces de rechange
Lista parti di ricambio

Onderdelenlijst
Lista de repuestos

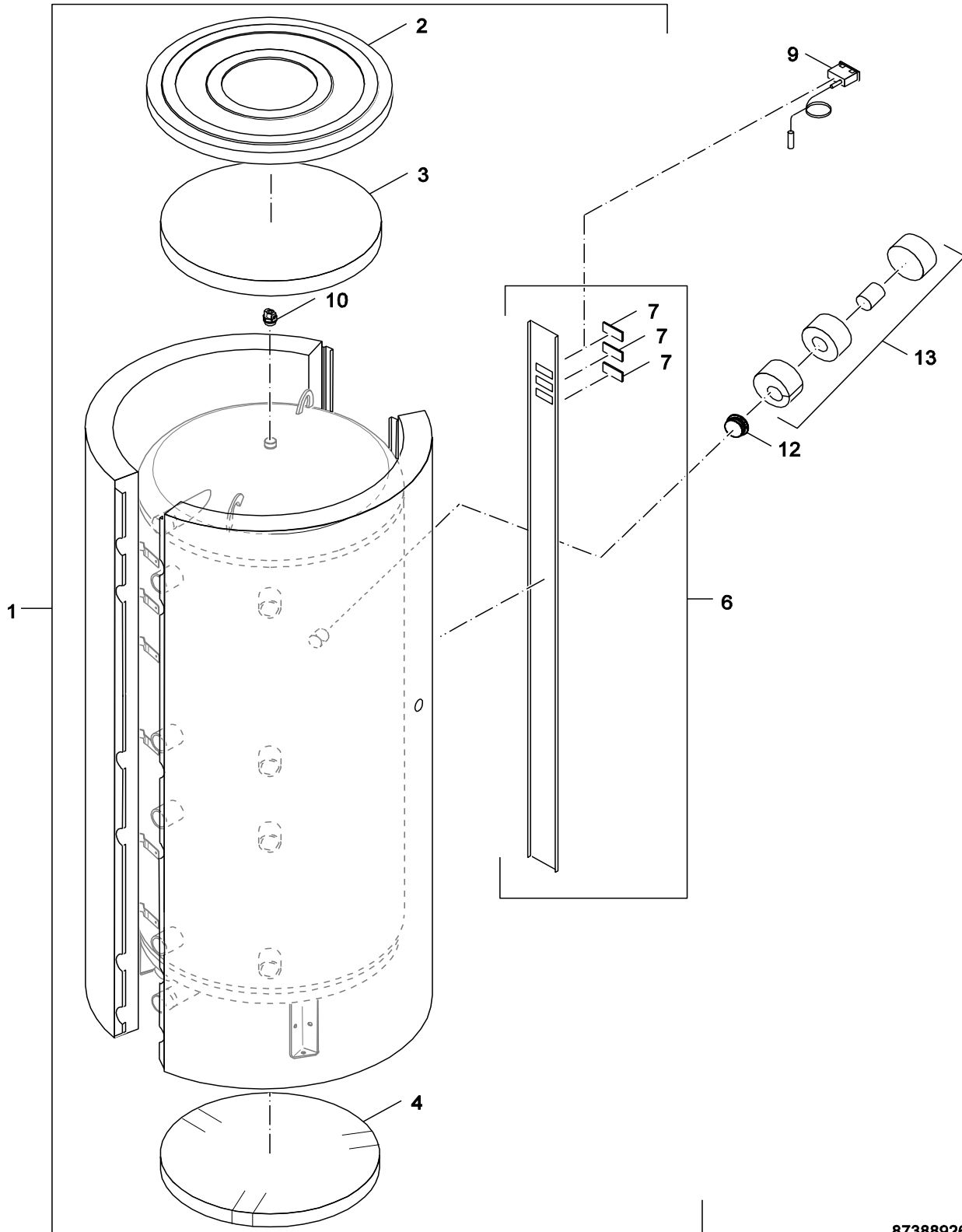

8738892600.aa.F

PSW 750-5, 1000-5 S-solar

2

- Pufferspeicher 500 - 1000L 120mm
- Buffer cylinder 500 - 1000L 120mm
- Ballon tampon 500 - 1000L 120mm
- Accumulatore puffer 500 - 1000L 120mm
- Bufferboiler 500 - 1000L 120mm
- Acumulador auxiliar 500 - 1000L 120mm

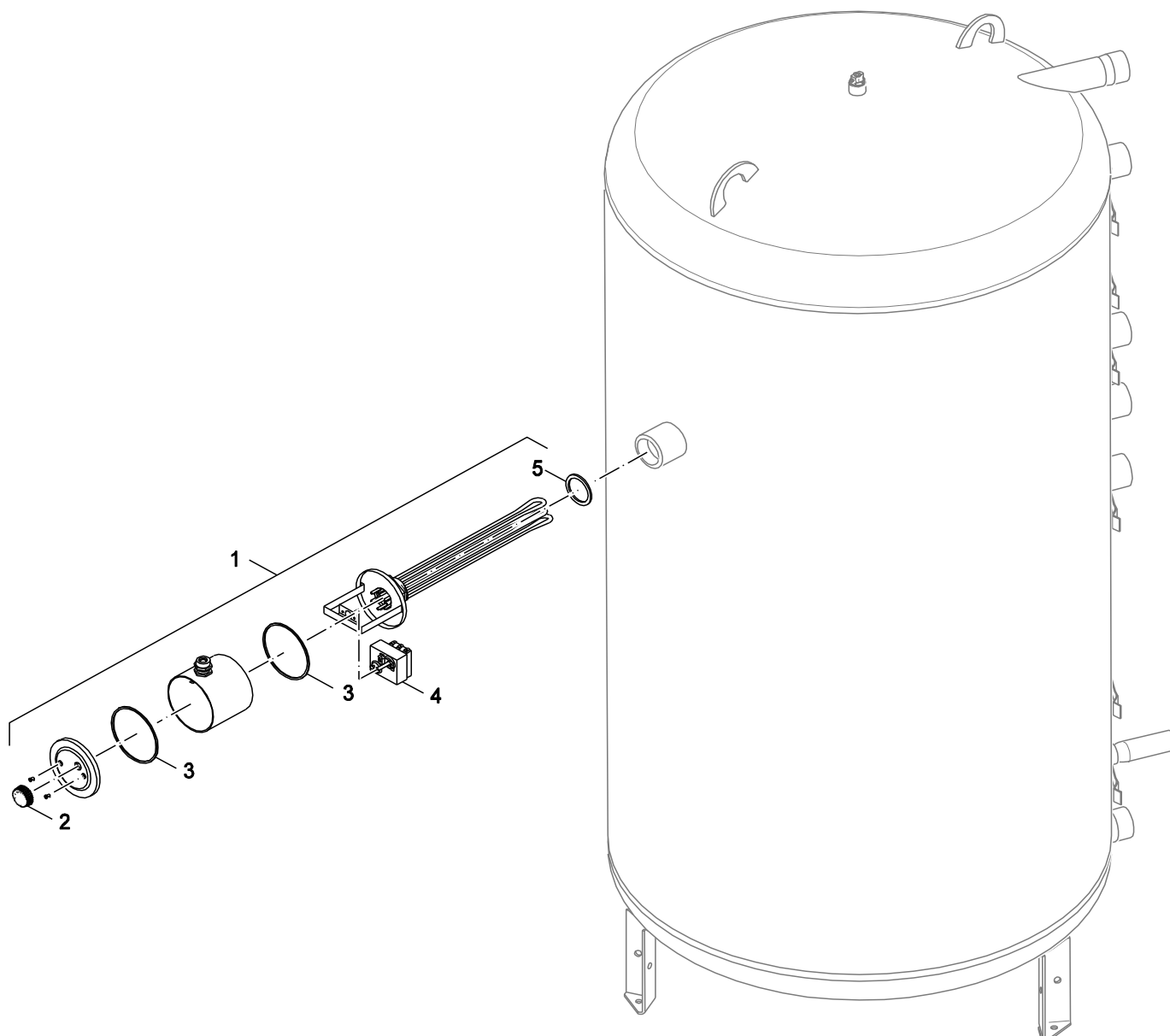

8738892614.aa.F

PSW 750-5, 1000-5 S-solar

3

Elektro-Heizeinsatz
Electric heater
Chauffage électrique
Resistenza elettrica
Elektroverwarming
Calefacción eléctrica

Übersetzungsliste
List of translations

Liste des traductions
Traduzione delle descrizioni

Vertalinglijst
Lista de traducciones

Pos	Description	Denomination	Descrizione	Benaming	Descripción
1	Element of construction	Groupe de construction	Gruppo di costruzione	Montagegroep	Grupo de construccion
1	Insulation buffer tank 750/5 80V Bo/Ju	Isolation Ballon tampon 750/5 80V Bo/Ju	Coibentazione Accumulat. 750/5 80V Bo/Ju	Isolatie Bufferboiler 750/5 80V Bo/Ju	Aislamiento Acumulador 750/5 80V Bo/Ju
1	Insulation buffer tank 1000/5 80V Bo/Ju	Isolation Ballon tampon 1000/5 80V Bo/Ju	Coibentazione Accumul. 1000/5 80V Bo/Ju	Isolatie Bufferboiler 1000/5 80V Bo/Ju	Aislamiento Acumul. 1000/5 80V Bo/Ju
2	Insulation bottom D790x80V	Isolation bas D790x80V	Coibentazione sotto D790x80V	Isolatie onder D790x80V	Aislamiento debajo D790x80V
3	Insulation 750/1000-80V top	Isolation 750/1000-80V Couvercle	Coibentazione 750/1000-80V Coperchio	Isolatie 750/1000-80V Deksel	Aislamiento 750/1000-80V Tapa
4	Cover top 750/1000-80 silver packed	Couvercle 750/1000-80 argent	Coperchio 750/1000-80 argentato	Afdekking 750/1000-80 zilver	Recubrimiento 750/1000-80 plata
7	Deairing 1/2	Vanne de purge 1/2"	Valvola di sfiato 1/2"	ONTLUCHTER 1/2" P500/750/100-120S	Válvula de purga de aire 1/2"
9	Plug G 1 1/2" with PTFE-Ring	Bouchon G1 1/2"	Tappo G 1 1/2" con anello di PTFE compl.	Pluggen G 1 1/2" met PTFE-ring compl.	Tapón G 1 1/2" con anillo de PTFE compl.
10	Cover electric heater silver	Couvercle Chauffage électrique argent	Coperchio Resistenza elettrica argentato	Afdekking Elektroverwarming zilver	Recubrimiento calefacción eléctrica plat
	Trademark Junkers	Marquage Junkers	Targhetta Junkers	LOGO JUNKERS ZELFKLEVEND	Marca Junkers
	Cable Adapter 3-way valve cpl.	Câble adaptateur Vanne d'inversion	Cavo di adattamento Valvola di inversion	Adapterkabel Omschakelventiel	Cable adaptador Válvula de inversión
2	Element of construction	Groupe de construction	Gruppo di costruzione	Montagegroep	Grupo de construccion
1	Insulation Buffer Tank 750-5/120	Isolation Ballon tampon 750-5/120	Coibentazione Accumul. puffer 750-5/120	Isolatie Bufferboiler 750-5/120	Aislamiento Acumul. auxiliar 750-5/120
1	Insulation Buffer Tank 1000-5/120	Isolation Ballon tampon 1000-5/120	Coibentazione Accumul. puffer 1000-5/120	Isolatie Bufferboiler 1000-5/120	Aislamiento Acumul. auxiliar 1000-5/120
2	Cover Top D1050 grey	Couvercle D1050 gris	Copertura di protezione D1050 grigio	Afdekking D1050 grijs	Recubrimiento D1050 girar
3	Insulation Cover D790x120 Fleece	Isolation Couvercle D790x120 toison	Coibentazione Coperchio D790x120	Isolatie Deksel D790x120 vlies	Aislamiento Tapa D790x120 vellón
4	Insulation Bottom D790x120 Fleece	Isolation bas D790x120 toison	Coibentazione sotto D790x120	Isolatie onder D790x120 vlies	Aislamiento debajo D790x120 vellón
6	Cover Front 750l grey	Couvercle 750 devant gris	Coperchio 750 davanti grigio	Afdekstrook 750 voor grijs	Recubrimiento 750 delante girar
6	Cover Front 1000 grey	Couvercle 1000 devant gris	Coperchio 1000 davanti grigio	Afdekstrook 1000 voor grijs	Recubrimiento 1000 delante girar
7	Cover plate 28x61x6 silver	Recouvrement 28x61x6 argent	Copertura 28x61x6 argento	Afdekking 28x61x6 zilver	Recubrimiento 28x61x6 plata
9	Digital thermometer with capillary 3 DTA	Thermom#tre numérique DTA	SONDA BOLLITORE DIGITALE DTA	THERMOMETER DIGITAAL P500/750/100-120S	Termometro Digital SU750
10	Deairing 1/2	Vanne de purge 1/2"	Valvola di sfiato 1/2"	ONTLUCHTER 1/2" P500/750/100-120S	Válvula de purga de aire 1/2"
12	Plug G 1 1/2" with PTFE-Ring	Bouchon G1 1/2"	Tappo G 1 1/2" con anello di PTFE compl.	Pluggen G 1 1/2" met PTFE-ring compl.	Tapón G 1 1/2" con anillo de PTFE compl.
13	Cover electric heater silver	Couvercle Chauffage électrique argent	Coperchio Resistenza elettrica argentato	Afdekking Elektroverwarming zilver	Recubrimiento calefacción eléctrica plat
	Trademark Junkers	Marquage Junkers	Targhetta Junkers	LOGO JUNKERS ZELFKLEVEND	Marca Junkers
	Cable Adapter 3-way valve cpl.	Câble adaptateur Vanne d'inversion	Cavo di adattamento Valvola di inversion	Adapterkabel Omschakelventiel	Cable adaptador Válvula de inversión
3	Element of construction	Groupe de construction	Gruppo di costruzione	Montagegroep	Grupo de construccion
1	2Kw 1PH/HEATER 1 1/2" w. Controllor	Resist elec 2kw avec thermostat	Resistenza elettrica 2KW 1 1/2"	Elektr. weerstand 6/4" + regeling 2 kW	Resistencia eléctrica 2 kw con brida 1
1	3Kw 1PH/HEATER 1 1/2" w. Controllor	Resist elec 3kw avec thermostat	Resistenza elettrica 3KW 1 1/2"	Elektr. weerstand 6/4" + regeling 3 kW	Resistencia eléctrica 3 kw con brida 1
1	4,5Kw 1PH/HEATER 1 1/2" w. Controllor	Resist elec 4,5kw tri avec thermostat	Resistenza elettrica 4,5KW 1 1/2"	Elektr. weerstand 6/4" + regeling 4,5 kW	Resistencia eléctrica 4,5 kw con brida
1	6Kw 1PH/HEATER 1 1/2" w. Controllor	Resist elec 6kw tri avec thermostat	Resist. elettr. 6kW per puffer P...S-Sol	Elektr. weerstand 6/4" + regeling 6 kW	Resistencia eléctrica 6 kw con brida 1
1	9Kw 1PH/HEATER 1 1/2" w. Controllor	Resist elec 9kw tri avec aquastat	Resist. elettr. 9kW per puffer P...S-Sol	Elektr. weerstand 6/4" + regeling 9 kW	Resistencia eléctrica 9 kw con brida
2	Rotary selector E-heater regulator	BOUTON DE REGLAGE RESISTANCE	Manopola Controllo E-riscaldatore	Regelknop regelaar e-radiateur	Botón giratorio acumulador
3	Gasket 106x114x2	JOINT 106x114x2mm	Guarnizione 106x114x2	Pakking 106x114x2	Junta resistencia 106x114x2
4	Control thermostat	Thermostat ballon ST1000/2	Regolatore di temperatura	Regelaquastaat voor elekt. weerstand	Regulador de temperatura
5	Gasket D48x60x3mm	JOINT D48X60X3mm	Guarnizione D 48x60x3 mm	Dichting D48x60x3mm	Junta D48x60x3mm

Gerätetypen Types of appliances	Types de chaudières Tipo apparecchi	Toesteltypes Tipos de aplicaciones	
Gerät Appliance Chaudière Apparecchio Toestel Aparato	Bestell-Nr. Ordering no. Numéro de commande N° d'ordine Bestelnummer Número el ordenar	Land Country Pays Paese Land Paese	Bemerkungen Remarks Remarques Osservazioni Opmerkingen Observaciones
PSW 750/80-5 S-Solar "SA1/2/4"	7 736 501 676	Belgien, Deutschland, Italien, Slowenien,	
PSW 750/120-5 S-Solar "SA1/2/4"	7 736 501 678	Belgien, Deutschland, Italien, Slowenien,	
PSW 750-5 S-solar "SA1/2/4"	8 718 544 886	Belgien, Deutschland, Italien, Slowenien,	
PSW 1000/80-5 S-Solar "SA1/2/4"	7 736 501 680	Belgien, Deutschland, Italien, Slowenien,	
PSW 1000/120-5 S-Solar "SA1/2/4"	7 736 501 682	Belgien, Deutschland, Italien, Slowenien,	
PSW 1000-5 S-solar "SA1/2/4"	8 718 544 896	Belgien, Deutschland, Italien, Slowenien,	
PSW 750/80-5 S-Solar "SA3"	7 736 501 779	England, Estland, Lettland, Litauen, Polen,	
PSW 750/120-5 S-Solar "SA3"	7 736 501 795	England, Estland, Lettland, Litauen, Polen,	
PSW 750-5 S-solar "SA3"	8 718 544 887	England, Estland, Lettland, Litauen, Polen,	
PSW 1000/80-5 S-Solar "SA3"	7 736 501 784	England, Estland, Lettland, Litauen, Polen,	
PSW 1000/120-5 S-Solar "SA3"	7 736 501 800	England, Estland, Lettland, Litauen, Polen,	
PSW 1000-5 S-solar "SA3"	8 718 544 897	England, Estland, Lettland, Litauen, Polen,	



Bosch Thermotechnik GmbH
D-73249 Wernau / Germany