

R2104

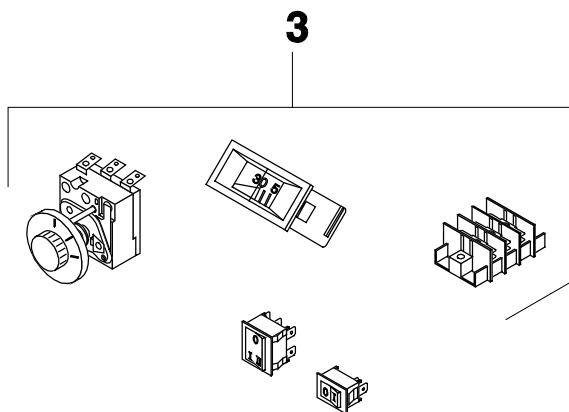

6720906315.ab.RS-HS2104

Buderus

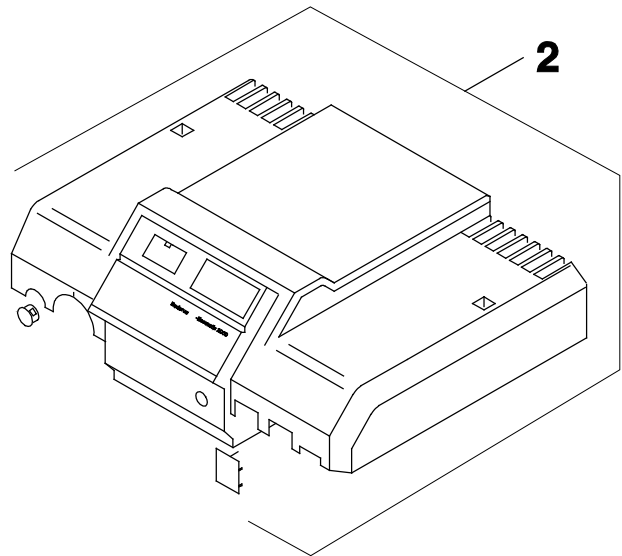
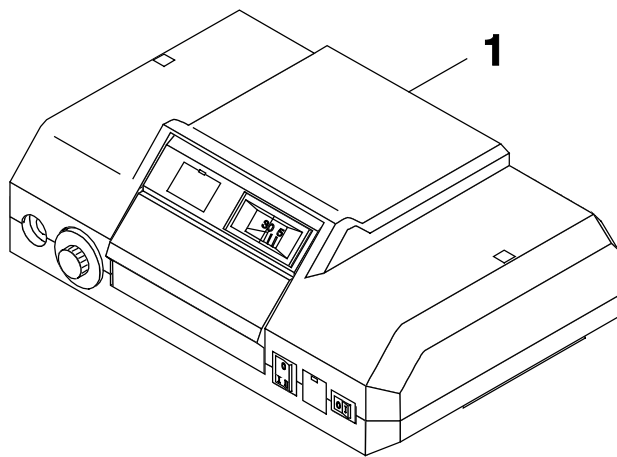
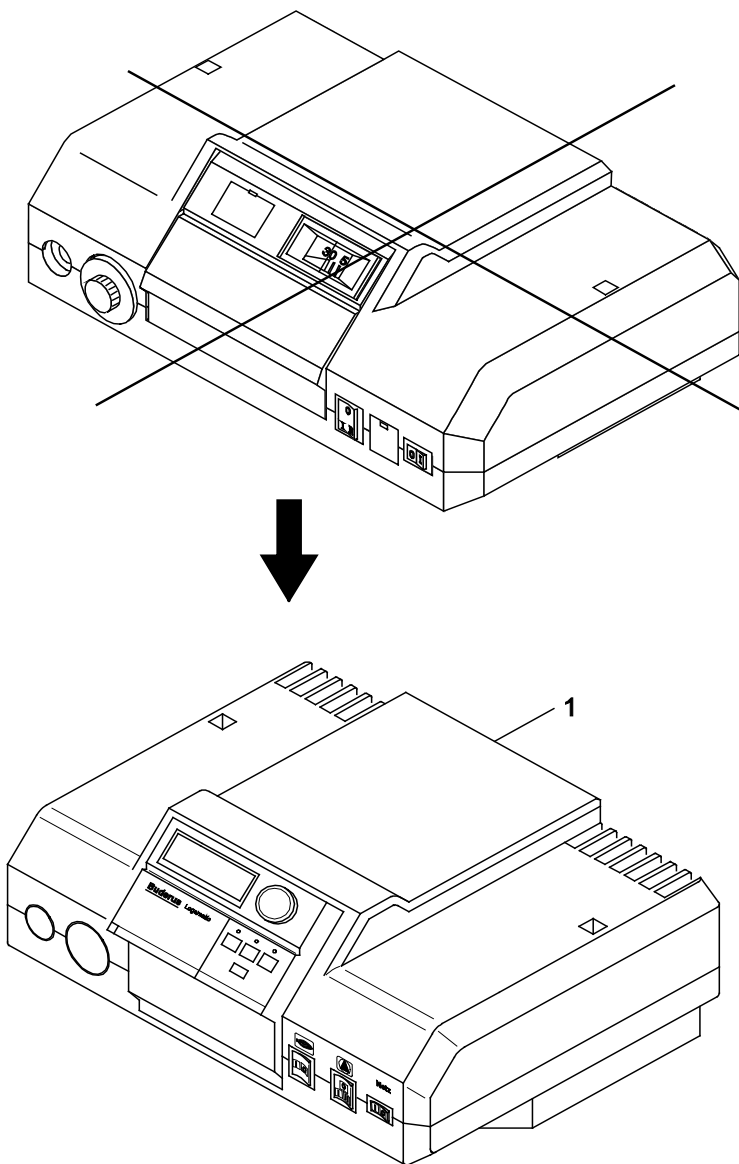

6720906316.aa.RS-Gerätevarianten HS2104

1

Gerätevarianten R2104
Contoller R2104
Régulateur R2104
Regolatore R2104
regulador R2104
regulador R2104

R2104

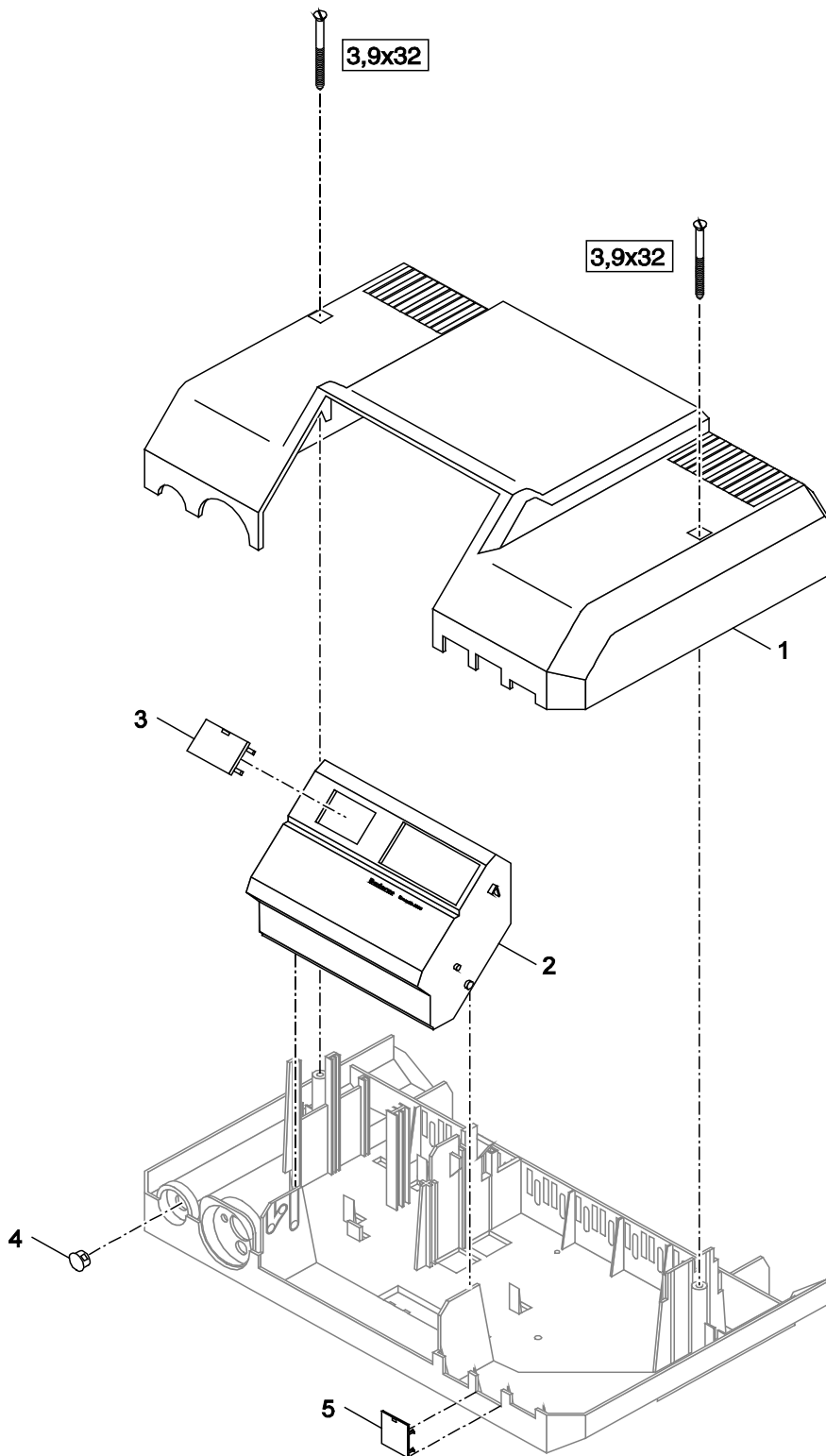

6720906317.aa.RS-Gehäuseeinzelteile HS2104

2

Gehäuseeinzelteile R2104
casing R2104
Carter R2104
Involucro R2104
caixa R2104
carcasa R2104

R2104

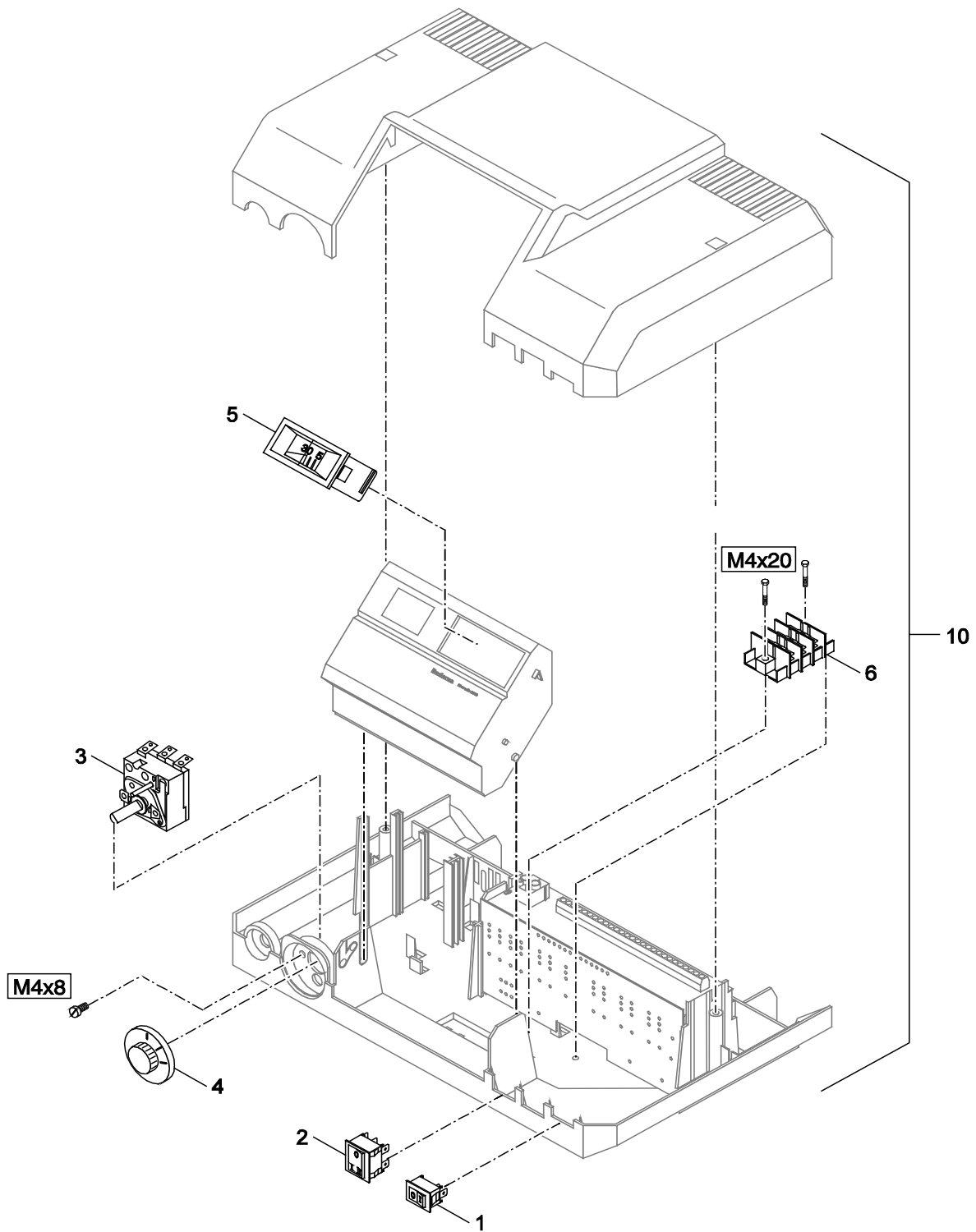

6720906318.ab.RS-Einzelteile HS2104

3

Module+Regler+Schalter R2104
Module+Contoller+switch R2104
Module+Régulateur+Interrupteur R2104
Modulo+Regolatore+Interruttore R2104
Módulo+regulador+interruptor R2104
Módulo+regulador+interruptor R2104

R2104

Pos	Bezeichnung Description Dénomination Descrizioni Designação Descripción	Bestell-Nr. Ordering no. Número de commande N° d'ordine N° de pedido Número el ordenar	HS2104																			Bemerkungen Remarks Remarques Osservazioni Observações Observaciones
1	Schalter Wipp 1 fach aus "0-I"	7 747 013 823	■																			
2	Geräteschalter 08 verp	7 747 013 825	■																			
3	Temp-Regler 0-90°C 3000mm	7 747 007 983	■																			
4	Bedienungsknopf 50-90°C Aut	8 718 585 544	■																			
5	Fernthermometer 0-120°C 3000WS	8 718 573 622	■																			
6	Steckverbinder 6-pol f R2104	67900493	■																			
10	Logamatic R2114 S07	8 718 587 393	■																			
R2104			Module+Regler+Schalter R2104 Module+Contoller+switch R2104 Module+Régulateur+Interrupteur R2104 Modulo+Regolatore+Interruttore R2104 Módulo+regulador+interruptor R2104 Módulo+regulador+interruptor R2104														3					

Gerätetypen
Types of appliances

Types de chaudières
Tipo apparecchi

Tipos de dispositivos
Tipos de aplicaciones

Gerät Appliance Chaudière Apparecchio Aparelho Aparato	Bestell-Nr. Ordering no. Numéro de commande N° d'ordine N° de pedido Número el ordenar	Land Country Pays Paese Pais Paese	Bemerkungen Remarks Remarques Osservazioni Observações Observaciones
HS2104	99908898	Deutschland, Frankreich, Italien, Kroatien, Tschechien, Spanien, Russland	

