

KB372

75 - 300kW

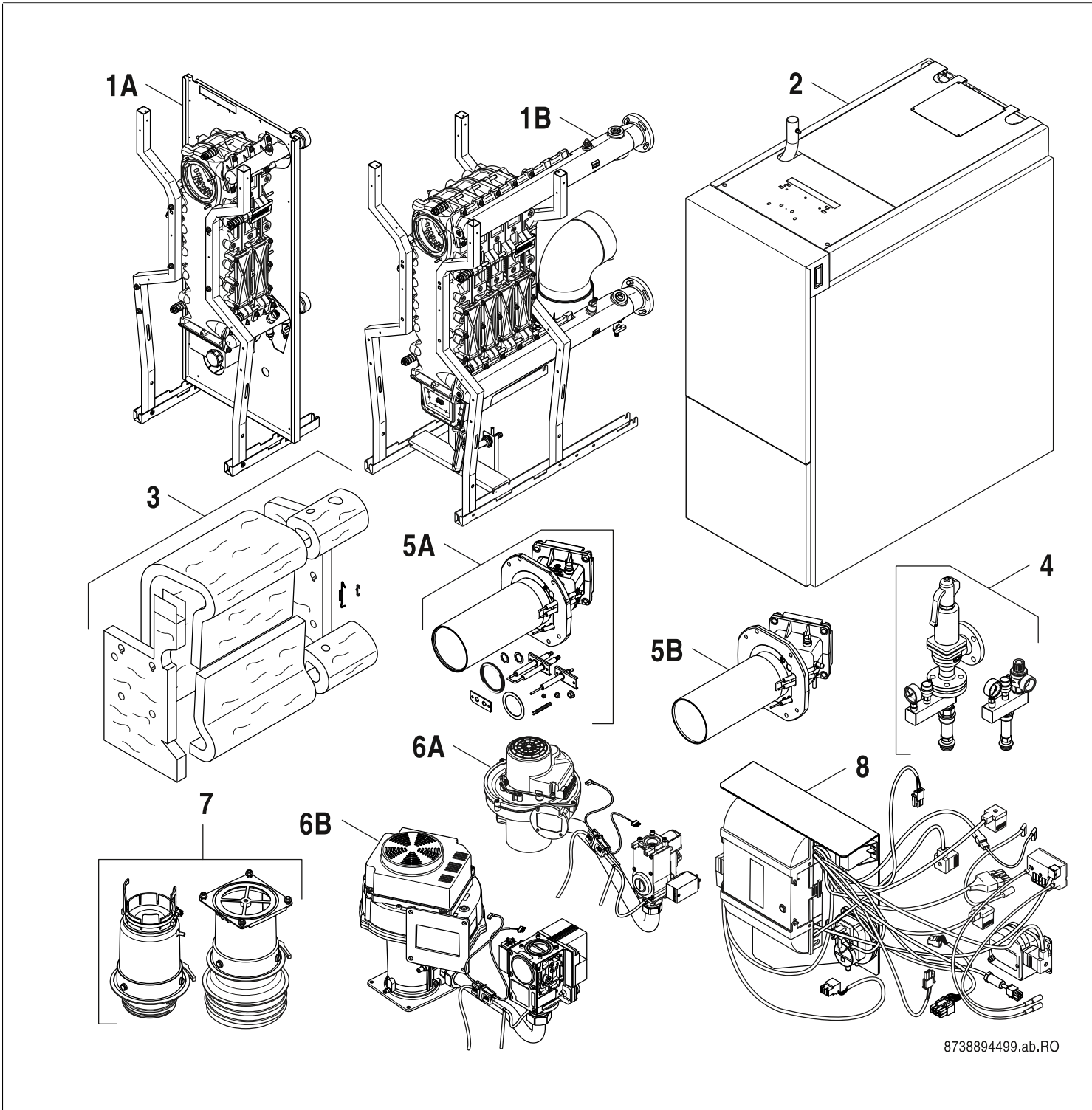

8738894499.ab.RO

[de] Wichtige Hinweise zur Installation/Montage

Die Installation/Montage muss durch eine für die Arbeiten zugelassene Fachkraft unter Beachtung der geltenden Vorschriften erfolgen.

[en] Important notes on installation/assembly

The installation/assembly must be carried out by a qualified contractor, following these instructions and in compliance with the applicable regulations.

[fr] Instructions importantes pour l'installation/le montage

L'installation/le montage doit être effectué(e) par un spécialiste qualifié pour les opérations concernées et dans le respect de la présente notice et des prescriptions applicables.

[bg] Важни указания във връзка с инсталацията/монтажа

Инсталацията/монтажът трябва да се извършва от лицензиран за работите специалист в съответствие с настоящото ръководство и с приложимите разпоредби.

[cs] Důležité pokyny k instalaci/montáži

Instalaci/montáž musí při dodržení pokynů uvedených v tomto návodu a platných předpisů provést odborný pracovník s příslušným oprávněním pro tyto práce.

[da] Vigtige anvisninger til installationen/monteringen

Installationen/monteringen skal foretages af en godkendt installatør under overholdelse af denne vejledning og de gældende forskrifter.

[el] Σημαντικές υποδείξεις για την εγκατάσταση/συναρμολόγηση

Η εγκατάσταση/τοποθέτηση πρέπει να ανατίθεται σε εκπαιδευμένο για τις συγκεκριμένες εργασίες τεχνικό προσωπικό με τήρηση αυτών των οδηγιών καθώς και των σχετικών προδιαγραφών.

[es] Indicaciones importantes para instalación/montaje

La instalación/el montaje debe realizarla personal especializado que esté autorizado para realizar estos trabajos y que tenga en cuenta estas instrucciones y la normativa vigente.

[et] Olulised juhised paigaldamiseks/montaažiks

Paigaldamist/montaaži tohib läbi viia vaid selleks volitusi omav spetsialist, arvestades kehtivaid nõudeid.

[nl-BE] Belangrijke aanwijzingen betreffende de installatie/montage

De installatie/montage moet worden uitgevoerd door een voor de werkzaamheden geautoriseerde installateur rekening houdend met deze handleiding en de geldende voorschriften.

[fi] Tärkeitä asennus- ja kokoonpano-ohjeita

Näihin töihin hyväksytyn ammattiasentajan pitää suorittaa asennus- ja kokoonpanotyöt voimassa olevien määräysten mukaisesti.

[hu] Fontos tudnivalók az installáláshoz/szereléshez

A telepítést/szerelést egy, a munkálatokra felhatalmazott szakembernek kell végeznie, jelen utasítás és az érvényes előírások figyelembevételével.

[it] Avvertenze importanti per l'installazione/il montaggio

L'installazione/il montaggio deve aver luogo ad opera di una ditta specializzata ed autorizzata in osservanza di queste istruzioni e delle direttive vigenti.

[ka] მნიშვნელოვანი მითითებები ინსტალაციისთვის/მონტაჟისთვის

ინსტალაცია/მონტაჟი უნდა განხორციელდეს სამუშაოებისთვის დაშვებული კვალიფიციური პერსონალის მიერ, მოქმედი განაწესის დაცვით.

[lt] Svarbios instaliavimo ir (arba) montavimo nuorodos

Instaliavimo / montavimo darbus, laikydamiės šios instrukcijos reikalavimų ir galiojančių taisyklių, privalo atlikti šioms darbams įgalioti specialistai.

[lv] Svarīgi norādījumi par iekārtas uzstādīšanu / montāžu

Uzstādīšanu/montāžu jāveic atbilstošajiem darbiem sertificētam speciālistam, ievērojot šo instrukciju un spēkā esošos noteikumus.

[nl] Belangrijke aanwijzingen betreffende de installatie/montage

De installatie/montage moet door een erkend installateur volgens de geldende voorschriften worden uitgevoerd.

[no] Viktig informasjon om installasjon/montering

Installasjonen/monteringen skal gjennomføres av autoriserte installatører, og installasjonsanvisningen samt gjeldende forskrifter skal følges.

[pl] Ważne wskazówki dotyczące instalacji/montażu

Instalację/montaż powinien wykonać specjalista uprawniony do tego typu prac z uwzględnieniem informacji podanych w niniejszej instrukcji oraz aktualnie obowiązujących przepisów.

[pt] Indicações importantes relativas à instalação/montagem

A instalação/montagem deve ser efectuada por um técnico autorizado para os trabalhos, respeitando este manual e as prescrições válidas.

[ro] Indicații importante privind instalarea/montajul

Instalarea/montajul trebuie realizate de către un specialist autorizat pentru lucrările respective, respectându-se prezentele instrucțiuni și prescripțiile valabile.

[ru] Важные указания по подключению/монтажу

Подключение/монтаж должны выполнять только специалисты, имеющие допуск к выполнению таких работ, при соблюдении требований этой инструкции и действующих норм и правил.

[sk] Dôležité pokyny týkajúce sa inštalácie/montáže

Inštaláciu/montáž musí vykonať odborný personál, ktorý má oprávnenie pre výkon týchto prác, pričom musí dodržiavať pokyny uvedené v tomto návode a platné predpisy.

[sl] Pomembni napotki za namestitvev/montažo

Inštalacija/montažo lahko izvede samo pooblaščen strokovnjak ob upoštevanju teh navodil in veljavnih predpisov.

[sr] Važna uputstva za ugradnju i montažu

Ovu instalaciju/montažu moraju da obave stručna lica koja su ovlašćena za obavljanje takvih radova u skladu sa ovim uputstvom i važećim propisima.

[sv] Viktiga anvisningar för installation/montering

Installationen/monteringen måste utföras av en behörig och tekniskt utbildad person enligt denna anvisning samt gällande föreskrifter.

[tr] Kurulum/Montaj ile ilgili önemli uyarılar

Kurulum/montaj, bu çalışmalarını yapmasına müsaade edilen uzman kişiler tarafından işbu kılavuz ve geçerli yönetmelikler dikkate alınarak yapılmalıdır.

[uk] Важливі вказівки щодо установки/монтажу

Встановлення/монтаж повинні виконувати фахівці, що допущені до виконання таких робіт, із дотриманням цієї інструкції та діючих приписів.

[zh] 安装方面的重要提示

安装和组装工作必须由经过许可的专业人员进行，同时必须遵守本说明书和现行法规的相关要求

[ar] ملاحظات هامة للتركيب/التجميع

يجب أن يتم التركيب/التجميع من قبل متخصص مصرح له بالعمل، مع مراعاة اللوائح السارية.

[fa] تذکرات مهم درباره نصب/مونتاژ

نصب/مونتاژ باید توسط فردی حرفه ای که مجاز به انجام این کار است، و همچنین با توجه کامل به مقررات مربوطه انجام شود.

Ersatzteilliste
Spare parts list

Liste des pièces de rechange
Lista parti di ricambio

Onderdelenlijst
Lista de repuestos

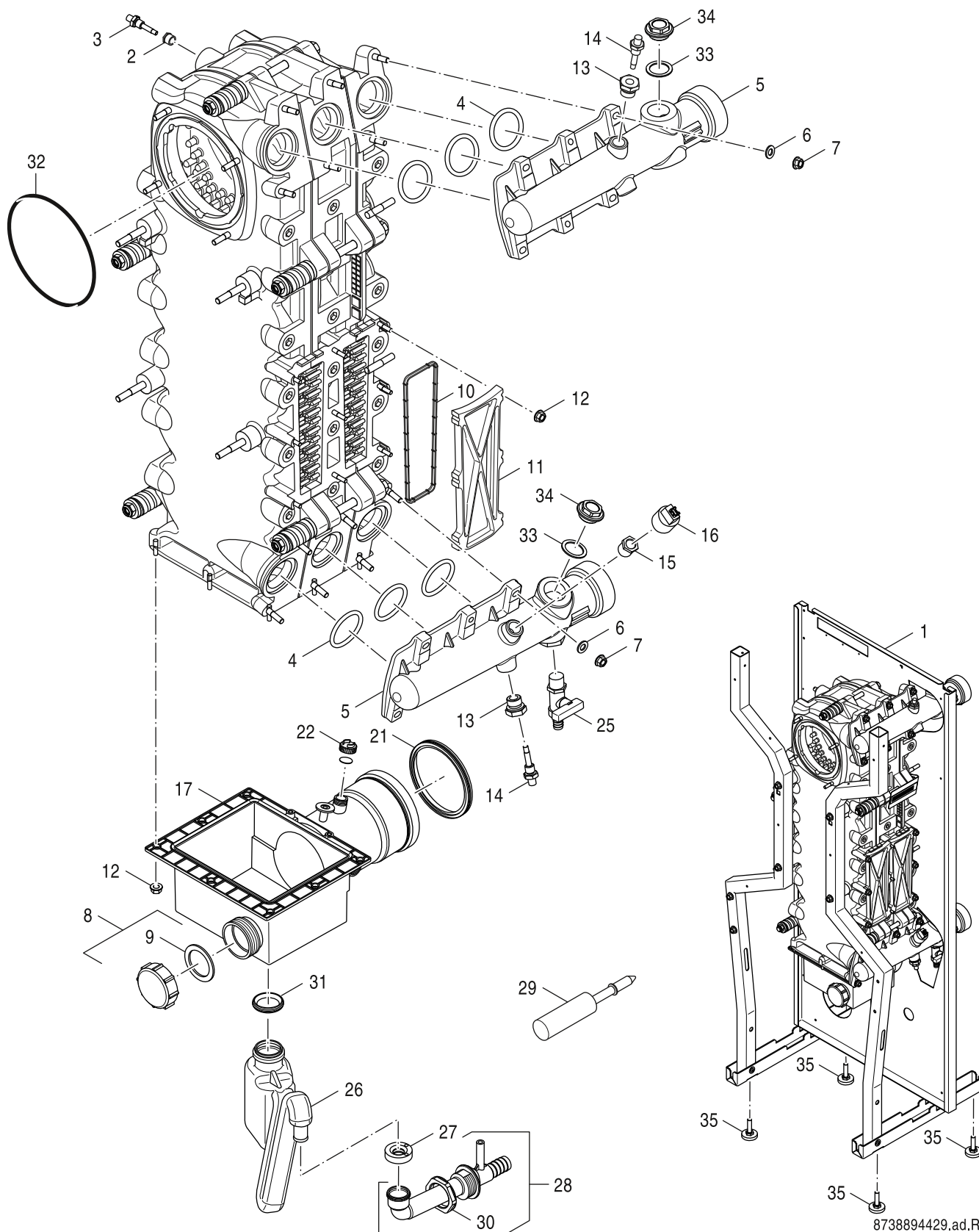

8738894429.ad.RO

1A
Kesselblock/Rahmen 75/100 kW
Boiler block/frame 75/100 kW
Bloc chaudière/cadre-support 75/100 kW
Caldera/Telaio 75/100 kW
Ketelblok/frame 75/100 kW
Caldera/bastidor 75/100 kW

KB372
75 - 300kW

Pos	Bezeichnung Description Dénomination Descrizioni Benaming Descripción	Bestell-Nr. Ordering no. Numéro de commande N° d'ordine Bestelnummer Número el ordenar	KB372-100/3 li	KB372-100/3 re	KB372-150/4 li	KB372-150/4 re	KB372-200/5 li	KB372-200/5 re	KB372-250/6 li	KB372-250/6 re	KB372-300/7 li	KB372-300/7 re	KB372-75/3 li	KB372-75/3 re	Bemerkungen Remarks Remarques Osservazioni Opmerkingen Observaciones
1	Kesselblock CLA-1 3Gld (r) everp	8 738 804 585	■										■		Darstellung ohne Wärmeschutz
1	Kesselblock CLA-1 3Gld (l) everp	8 738 804 595	■										■		Darstellung ohne Wärmeschutz
2	Red-Nippel Rp 3/4xG1/4 MS everp	6 303 841 5	■	■									■	■	
3	Kessel-/STB-FühlerG1/4 45lg everp	6 302 487 7	■	■									■	■	
4	O-Ring 53,34 x 5,33 (14x)	8 738 804 665	■	■									■	■	
5	Vor- / Rücklaufrohr CLA-1 3Gld everp	8 738 804 664	■	■									■	■	
6	Scheibe ISO 7089 A8,4 A3K (10x)	7 747 022 054	■	■									■	■	
7	6kt-Mutter DIN6923 M8 A3K (10x) everp	8 718 571 267 0	■	■									■	■	
8	Kappe GPN800 G2" PP gelb everp	8 738 804 599	■	■									■	■	
9	Dichtung D60x45x2 Viton everp	8 738 804 600	■	■									■	■	
10	Dichtung Reinigungsd. Block CLA-1 sp (2x)	8 738 804 659	■	■									■	■	
11	Reinigungsdeckel Block CLA-1 everp	8 738 804 658	■	■									■	■	
12	6kt-Mutter M6 (8x) everp	8 718 580 072	■	■									■	■	
13	Reduzierstück 1/2x1/4 everp	8 718 582 109	■	■									■	■	
14	Vor-/Rücklauffühler G1/4 45lg everp	6 304 167 7	■	■									■	■	
15	Reduzierstück R1/2xG3/8 m Dichtung everp	8 718 574 614 0	■	■									■	■	
16	Druck-Transmitter Typ503.93010111 everp	8 738 804 598	■	■									■	■	
17	Kondensatwanne CLA-1 3Gld kpl everp	8 738 804 671	■	■									■	■	Silikon, Pos.29 mitbestellen
21	Lippendichtung DN110, PerOxyd Set (5Stk)	8 709 058 2	■	■									■	■	
22	Schutzkappe	8 716 111 252 0	■	■									■	■	
25	KFE-Hahn R1/2 Bekaert 048-250 everp	8 718 574 837	■	■									■	■	
26	Siphon	7 746 900 147	■	■									■	■	
27	Lippendichtung DN18 (5x)	7 100 819	■	■									■	■	
28	Kondensatablauf everp	8 718 583 245	■	■									■	■	
29	Silikon Wezilil EV-300rot bis 300°Ceverp	8 718 590 462	■	■									■	■	
30	Gegenmutter PG29 5x everp	8 718 583 247	■	■									■	■	
31	Lippendichtung 29,8 x 6,1 (5x)	7 100 742	■	■									■	■	
32	O-ring ISO3601-1-365B-177,17x5,33 everp	8 738 804 597	■	■									■	■	
33	Dichtung D33x44x2 grafitiert everp	8 718 584 676	■	■									■	■	
34	Stopfen G 1 everp	8 718 584 633	■	■									■	■	
35	Gerätefuß M10x51 everp (4x)	6 302 865 7	■	■									■	■	

KB372
75 - 300kW

Kesselblock/Rahmen 75/100 kW
Boiler block/frame 75/100 kW
Bloc chaudière/cadre-support 75/100 kW
Caldera/Telaio 75/100 kW
Ketelblok/frame 75/100 kW
Caldera/bastidor 75/100 kW

1A

Ersatzteilliste
Spare parts list

Liste des pièces de rechange
Lista parti di ricambio

Onderdelenlijst
Lista de repuestos

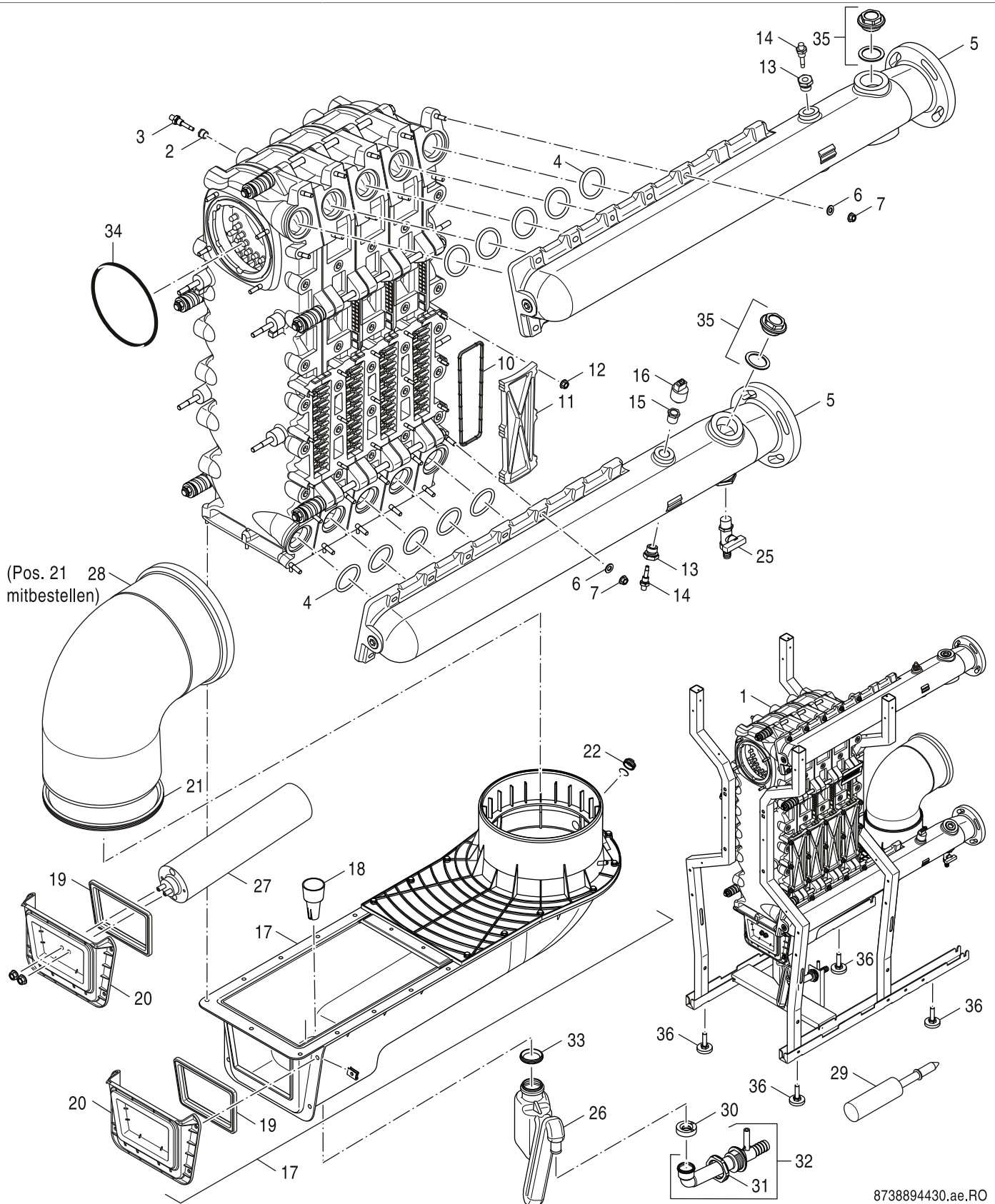

8738894430.ae.RO

1B
Kesselblock/Rahmen 150-300 kW
Boiler block/frame 150-300 kW
Bloc chaudière/cadre-support 150-300 kW
Caldera/bastidor 150-300 kW
Ketelblok/frame 150-300 kW
Caldera/bastidor 150-300 kW

KB372
75 - 300kW

Pos	Bezeichnung Description Dénomination Descrizioni Benaming Descripción	Bestell-Nr. Ordering no. Numéro de commande N° d'ordine Bestelnummer Número el ordenar												Bemerkungen Remarks Remarques Osservazioni Opmerkingen Observaciones				
			KB372-100/3 li	KB372-100/3 re	KB372-150/4 li	KB372-150/4 re	KB372-200/5 li	KB372-200/5 re	KB372-250/6 li	KB372-250/6 re	KB372-300/7 li	KB372-300/7 re	KB372-75/3 li		KB372-75/3 re			
1	Kesselblock CLA-1 7Gld (r) everp	8 738 804 577																Darstellung ohne Wärmeschutz
1	Kesselblock CLA-1 6Gld (r) everp	8 738 804 579																Darstellung ohne Wärmeschutz
1	Kesselblock CLA-1 5Gld (r) everp	8 738 804 581																Darstellung ohne Wärmeschutz
1	Kesselblock CLA-1 4Gld (r) everp	8 738 804 583																Darstellung ohne Wärmeschutz
1	Kesselblock CLA-1 7Gld (l) everp	8 738 804 587																Darstellung ohne Wärmeschutz
1	Kesselblock CLA-1 6Gld (l) everp	8 738 804 589																Darstellung ohne Wärmeschutz
1	Kesselblock CLA-1 5Gld (l) everp	8 738 804 591																Darstellung ohne Wärmeschutz
1	Kesselblock CLA-1 4Gld (l) everp	8 738 804 593																Darstellung ohne Wärmeschutz
2	Red-Nippel Rp 3/4xG1/4 MS everp	6 303 841 5																
3	Kessel-/STB-FühlerG1/4 45lg everp	6 302 487 7																
4	O-Ring 53,34 x 5,33 (14x)	8 738 804 665																
5	Vor- / Rücklaufrohr CLA-1 7Gld everp	8 738 804 660																
5	Vor- / Rücklaufrohr CLA-1 6Gld everp	8 738 804 661																
5	Vor- / Rücklaufrohr CLA-1 5Gld everp	8 738 804 662																
5	Vor- / Rücklaufrohr CLA-1 4Gld everp	8 738 804 663																
6	Scheibe ISO 7089 A8,4 A3K (10x)	7 747 022 054																
7	6kt-Mutter DIN6923 M8 A3K (10x) everp	8 718 571 267 0																
10	Dichtung Reinigungsd. Bkck CLA-1 sp (2x)	8 738 804 659																
11	Reinigungsdeckel Block CLA-1 everp	8 738 804 658																
12	6kt-Mutter M6 (8x) everp	8 718 580 072																
13	Reduzierstück 1/2x1/4 everp	8 718 582 109																
14	Vor-/Rücklauffühler G1/4 45lg everp	6 304 167 7																
15	Reduzierstück R1/2xG3/8 m Dichtung everp	8 718 574 614 0																
16	Druck-Transmitter Typ503.93010111 everp	8 738 804 598																
17	Kondensatwanne CLA-1 4Gld (r) everp	8 738 805 689																Silikon, Pos.29 mitbestellen
17	Kondensatwanne CLA-1 5Gld (r) everp	8 738 805 690																Silikon, Pos.29 mitbestellen
17	Kondensatwanne CLA-1 6Gld (r) everp	8 738 805 691																Silikon, Pos.29 mitbestellen
17	Kondensatwanne CLA-1 7Gld (r) everp	8 738 805 692																Silikon, Pos.29 mitbestellen
18	Kondensatüberlauf Wanne CLA-1 everp	8 738 804 666																
19	Dichtung Serv.deckel Wanne CLA-1 everp	8 738 804 657																
20	Reinigungsdeckel Kondenswanne CLA-1everp	8 738 804 656																
20	Reinig.dckl Kondenswanne CLA-1 200 everp	8 738 804 673																
21	Lippendichtung DN160 Centrotherm everp	6 303 786 7																
21	Lippendichtung DN200 Centrotherm everp	6 303 786 8																
22	Schutzkappe	8 716 111 252 0																
25	KFE-Hahn R1/2 Bekaert 048-250 everp	8 718 574 837																
26	Siphon	7 746 900 147																
27	Resonator CLA-1 200 everp	8 738 804 672																
28	Abgasbogen DN-160 everp	8 738 804 601																Dichtung 63037867 mitbestellen
28	Abgasbogen 87° DN200 everp	8 738 804 602																Dichtung 63037868 mitbestellen
29	Silikon Wezilil EV-300rot bis 300°Ceverp	8 718 590 462																
30	Lippendichtung DN18 (5x)	7 100 819																
31	Gegenmutter PG29 5x everp	8 718 583 247																
32	Kondensatablauf everp	8 718 583 245																
33	Lippendichtung 29,8 x 6,1 (5x)	7 100 742																
34	O-ring ISO3601-1-365B-177,17x5,33 everp	8 738 804 597																
35	Blindstopfen G 1 1/4" re everp	8 718 571 258 0																
36	Gerätefuß M10x51 everp (4x)	6 302 865 7																
KB372											Kesselblock/Rahmen 150-300 kW Boiler block/frame 150-300 kW Bloc chaudière/cadre-support 150-300 kW Caldera/bastidor 150-300 kW Ketelblok/frame 150-300 kW Caldera/bastidor 150-300 kW							1B
75 - 300kW																		

Ersatzteilliste
Spare parts list

Liste des pièces de rechange
Lista parti di ricambio

Onderdelenlijst
Lista de repuestos

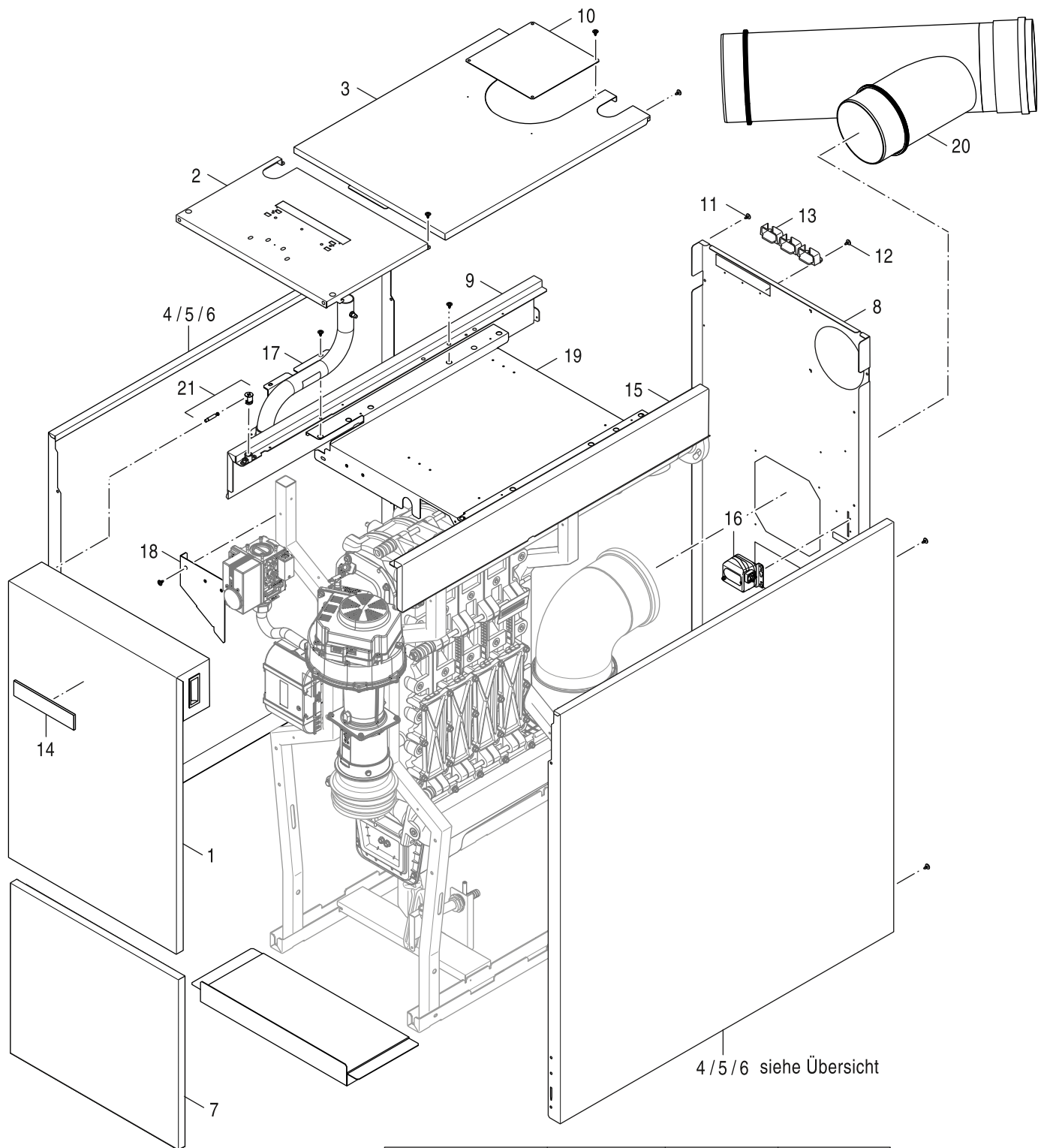

Kesselgröße kW	75/100	150	200-300
Seitenwand vorne	Pos. 4	Pos. 5	Pos. 4
Seitenwand hinten	—	Pos. 5	Pos. 6

8738894431.ae.RO

2

Verkleidung
Casing
Habillage
Rivestimento
Toestelmantel
Revestimiento

KB372
75 - 300kW

Pos	Bezeichnung Description Dénomination Descrizioni Benaming Descripción	Bestell-Nr. Ordering no. Numéro de commande N° d'ordine Bestelnummer Número el ordenar	KB372-100/3 li	KB372-100/3 re	KB372-150/4 li	KB372-150/4 re	KB372-200/5 li	KB372-200/5 re	KB372-250/6 li	KB372-250/6 re	KB372-300/7 li	KB372-300/7 re	KB372-75/3 li	KB372-75/3 re	Bemerkungen Remarks Remarques Osservazioni Opmerkingen Observaciones
1	Vorderwand oben CLA-1 BU everp	8 738 804 927	■	■	■	■	■	■	■	■	■	■	■		
2	Haube vorn CLA-1 75-300 everp	8 738 804 921	■	■	■	■	■	■	■	■	■	■	■		
3	Haube hinten CLA-1 75/100 everp	8 738 804 922	■	■								■	■		
3	Haube hinten CLA-1 150 everp	8 738 804 923			■	■									
3	Haube hinten CLA-1 200-300 everp	8 738 804 924					■	■	■	■	■				
4	Seitenwand 569 CLA-1 BU everp	8 738 804 929	■	■			■	■	■	■	■	■	■		Verwendung, s. Grafik
5	Seitenwand 472 CLA-1 BU everp	8 738 804 931			■	■									Verwendung, s. Grafik
6	Seitenwand 657 CLA-1 BU everp	8 738 804 933					■	■	■	■	■				Verwendung, s. Grafik
7	Vorderwand unten CLA-1 everp	8 738 804 925	■	■	■	■	■	■	■	■	■	■	■		
8	Rückwand CLA-1 75-100 (r) everp	8 738 804 937		■									■		
8	Rückwand CLA-1 150 (r) everp	8 738 804 938				■									
8	Rückwand CLA-1 200-300 (r) everp	8 738 804 939					■		■		■				
8	Rückwand CLA-1 75-100 (l) everp	8 738 804 940	■										■		
8	Rückwand CLA-1 150 (l) everp	8 738 804 941			■										
8	Rückwand CLA-1 200-300 (l) everp	8 738 804 942					■		■		■				
9	Traverse oben links CLA-1 200-300 everp	8 738 804 950					■	■	■	■	■	■			
9	Traverse oben links CLA-1 150 everp	8 738 804 952			■	■									
9	Traverse oben links CLA-1 75-100 everp	8 738 804 954	■	■									■	■	
10	Abdeckung Haube hinten CLA-1 everp	8 738 804 934			■	■	■	■	■	■	■	■			
11	Flachkopfschraube ST3,9x9,5 A3T (10x)	7 747 026 999	■	■	■	■	■	■	■	■	■	■	■	■	
12	Blechschaube C ST3,9x13 A3T (10x) everp	8 718 572 168 0	■	■	■	■	■	■	■	■	■	■	■	■	
13	Kabelhalter (5x) everp	8 718 584 331	■	■	■	■	■	■	■	■	■	■	■	■	
14	Logo Buderus 186mm everp	8 718 586 514	■	■	■	■	■	■	■	■	■	■	■	■	
15	Traverse oben rechts CLA-1 200-300 everp	8 738 804 949					■	■	■	■	■				
15	Traverse oben rechts CLA-1 150 everp	8 738 804 951			■	■									
15	Traverse oben rechts CLA-1 75-100 everp	8 738 804 953	■	■									■	■	
16	Druckschalter DL10KH-5WZ everp	8 738 805 150	■	■									■	■	
16	Druckschalter DL10KH-5WZ 9,5 everp	8 738 806 365			■	■	■	■	■	■	■	■			
17	Gasanschlussrohr VM CLA-1 150-300 everp	8 738 804 935			■	■	■	■	■	■	■	■			
17	Gasanschlussrohr VM CLA-1 75/100 everp	8 738 804 936	■	■									■	■	
18	Halteblech Trafo CLA-1 everp	8 738 804 948	■	■	■		■		■		■		■	■	
19	Blech Oberteil CLA-1 150 (l) everp	8 738 804 944			■										
19	Blech Oberteil CLA-1 150 everp	8 738 804 945				■									
19	Blech Oberteil CLA-1 200-300 (l) everp	8 738 804 946					■		■		■				
19	Blech Oberteil CLA-1 200-300 everp	8 738 804 947					■		■		■				
20	Abgassammler Kaskade DN250/DN200 everp	8 732 919 905					■	■	■	■	■				Verwendung nur bei Kaskade
20	Abgassammler Kaskade DN200/DN160 everp	8 732 919 906			■	■									Verwendung nur bei Kaskade
20	Abgassammler Kaskade DN160/DN110 everp	8 732 919 907	■	■									■	■	Verwendung nur bei Kaskade
21	Montageset Vorderwand everp	8 718 583 089	■	■	■	■	■	■	■	■	■	■	■	■	

KB372
75 - 300kW

Verkleidung
Casing
Habillage
Rivestimento
Toestelmantel
Revestimiento

2

Ersatzteilliste
Spare parts list

Liste des pièces de rechange
Lista parti di ricambio

Onderdelenlijst
Lista de repuestos

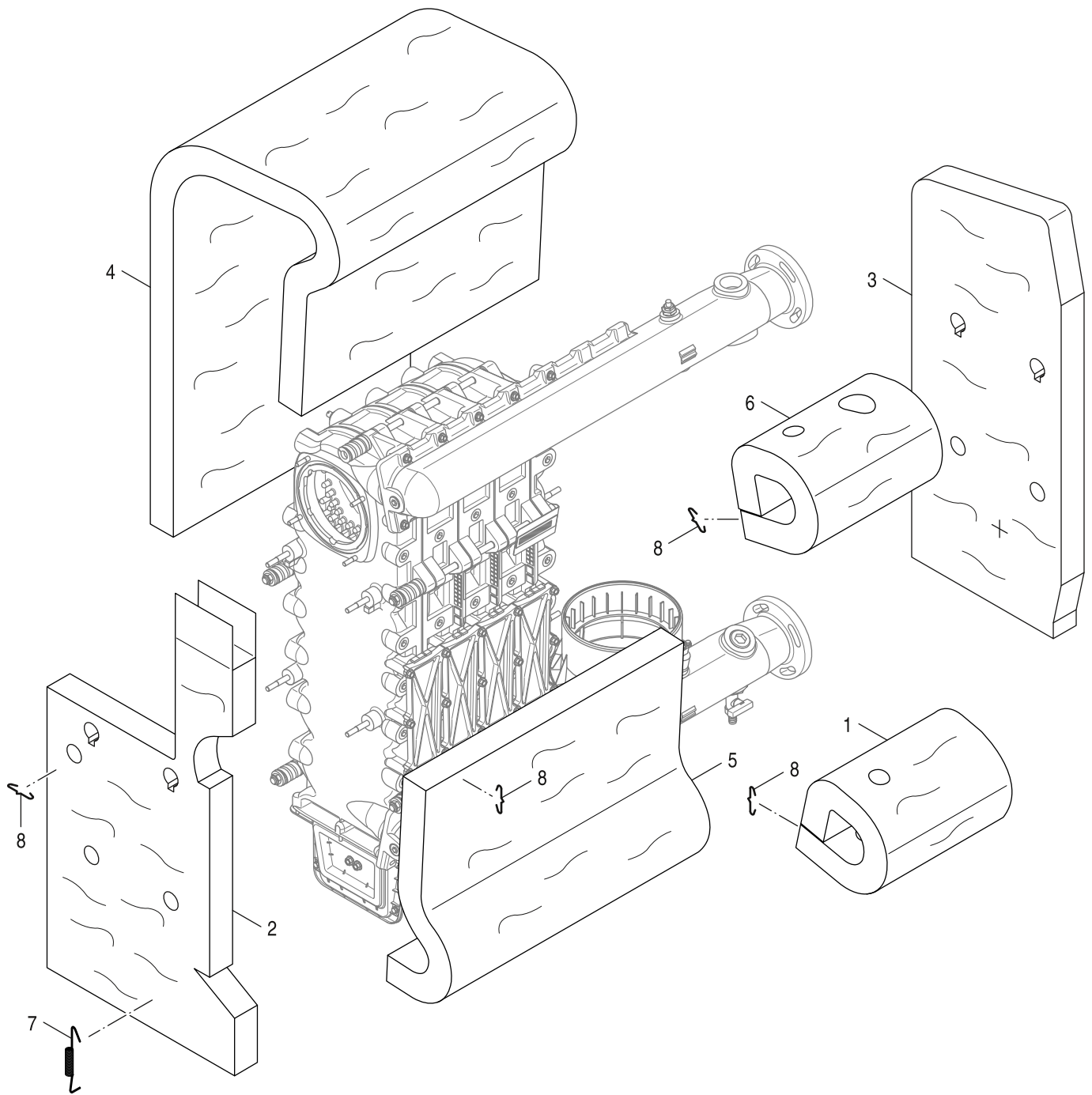

8738894432.aa.RO

3

Wärmeschutz
Thermal insulation
Thermal insulation
Isolamento termico
Isolatie
Aislamiento térmico

KB372
75 - 300kW

Pos	Bezeichnung Description Dénomination Descrizioni Benaming Descripción	Bestell-Nr. Ordering no. Numéro de commande N° d'ordine Bestelnummer Número el ordenar	KB372-100/3 li	KB372-100/3 re	KB372-150/4 li	KB372-150/4 re	KB372-200/5 li	KB372-200/5 re	KB372-250/6 li	KB372-250/6 re	KB372-300/7 li	KB372-300/7 re	KB372-75/3 li	KB372-75/3 re	Bemerkungen Remarks Remarques Osservazioni Opmerkingen Observaciones
1	Wärmeschutz Rücklauf CLA -1 250 everp	8 738 804 517							■	■					
1	Wärmeschutz Rückl. 150/300 everp	8 738 804 518			■	■					■	■			
1	Wärmeschutz Rücklauf CLA-1 200 everp	8 738 804 519					■	■							
2	Wärmeschutz vorne CLA-1 75-500 everp	8 738 804 520	■	■	■	■	■	■	■	■	■	■	■	■	
3	Wärmeschutz hinten CLA -1 75-500 everp	8 738 804 521	■	■	■	■	■	■	■	■	■	■	■	■	
4	Wärmeschutz Kesselbl CLA -1 75/100 everp	8 738 804 522	■	■								■	■		
4	Wärmeschutz Kesselblock CLA -1 150 everp	8 738 804 523			■	■									
4	Wärmeschutz Kesselblock CLA -1 200 everp	8 738 804 524					■	■							
4	Wärmeschutz Kesselblock CLA -1 250 everp	8 738 804 525							■	■					
4	Wärmeschutz Kesselblock CLA -1 300 everp	8 738 804 526									■	■			
5	Wärmeschutz Servd. CLA -1 75/100 everp	8 738 804 527	■	■								■	■		
5	Wärmeschutz Serviced. CLA -1 150 everp	8 738 804 528			■	■									
5	Wärmeschutz Serviced. CLA -1 200 everp	8 738 804 529					■	■							
5	Wärmeschutz Serviced. CLA -1 250 everp	8 738 804 530							■	■					
5	Wärmeschutz Serviced. CLA -1 300 everp	8 738 804 531									■	■			
6	Wärmeschutz Vorlauf CLA -1 250 everp	8 738 804 532							■	■					
6	Wärmeschutz Vorlauf CLA -1 150/300 everp	8 738 804 533			■	■					■	■			
6	Wärmeschutz Vorlauf CLA -1 200 everp	8 738 804 534					■	■							
7	Spannfedern (5x) everp	6 304 377 2	■	■	■	■	■	■	■	■	■	■	■	■	
8	Haltefeder (10x) everp	7 747 016 084	■	■	■	■	■	■	■	■	■	■	■	■	

KB372
75 - 300kW

Wärmeschutz
Thermal insulation
Thermal insulation
Isolamento termico
Isolatie
Aislamiento térmico

3

Ersatzteilliste
Spare parts list

Liste des pièces de rechange
Lista parti di ricambio

Onderdelenlijst
Lista de repuestos

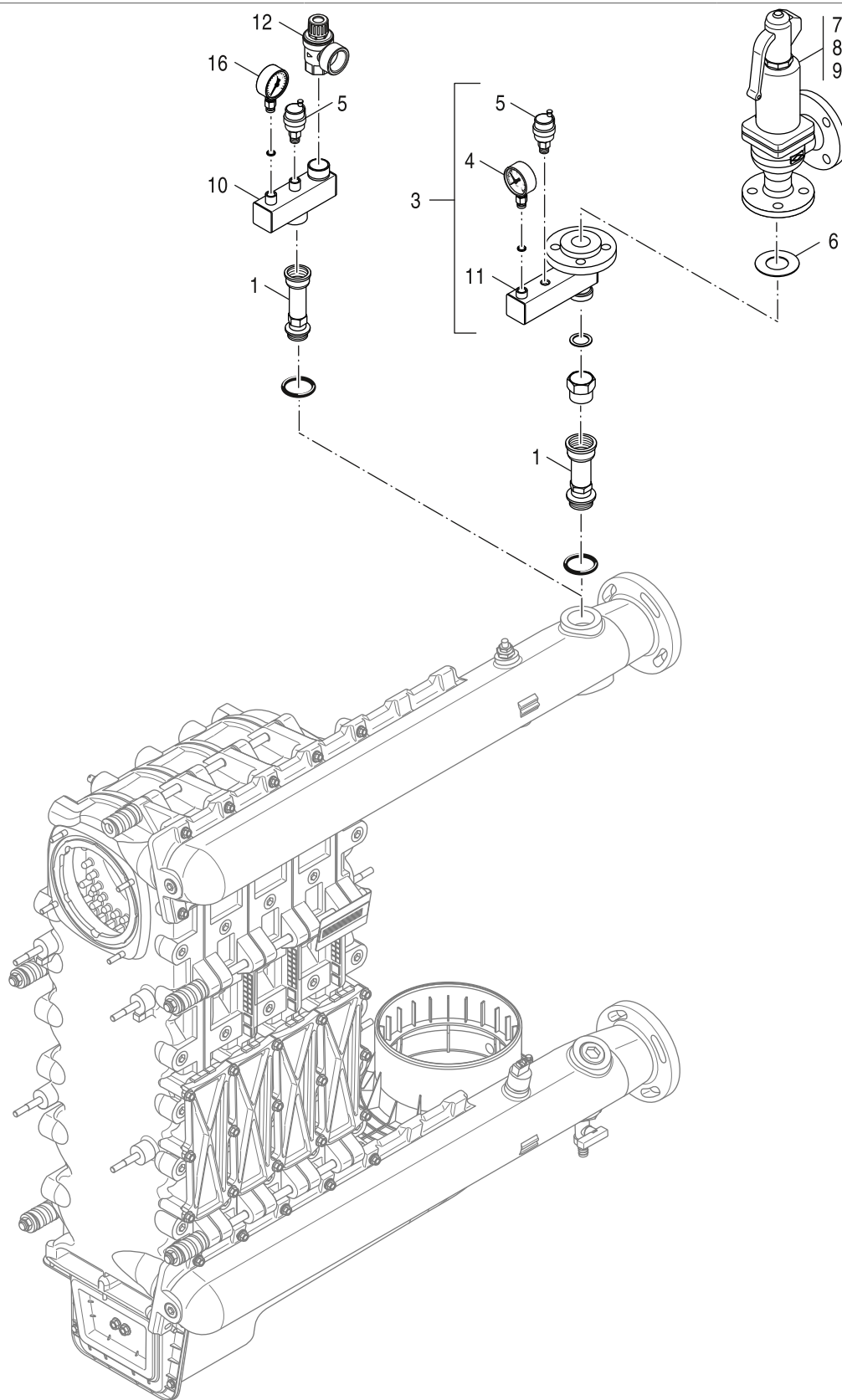

8738894433.ab.RO

4

Anschlußteile
Connection parts
Raccordement
Collegamento
Aansluiting
Conexión

KB372
75 - 300kW

Pos	Bezeichnung Description Dénomination Descrizioni Benaming Descripción	Bestell-Nr. Ordering no. Numéro de commande N° d'ordine Bestelnummer Número el ordenar	KB372-100/3 li	KB372-100/3 re	KB372-150/4 li	KB372-150/4 re	KB372-200/5 li	KB372-200/5 re	KB372-250/6 li	KB372-250/6 re	KB372-300/7 li	KB372-300/7 re	KB372-75/3 li	KB372-75/3 re	Bemerkungen Remarks Remarques Osservazioni Opmerkingen Observaciones
1	Verlängerung G1x120 V2 everp	8 718 585 117	■	■											
1	Verlängerung G1½x120 V2 everp	8 718 585 118			■	■	■	■	■	■	■	■			
3	Sicherheits-Set 1 1/4" 4-6bar	8 732 908 163	■	■	■	■	■	■	■	■	■	■	■	■	Zubehör
4	Röhrenf Mano m 2 100mm D 1/2"0-10bar	8 118 860 5	■	■	■	■	■	■	■	■	■	■	■	■	Zubehör
5	Entlüfter Autom m. Absperrvent 3/8 everp	8 718 585 257	■	■	■	■	■	■	■	■	■	■	■	■	
6	Flachdichtung PN16 DN32 43x82x2 everp	8 718 573 733 0	■	■	■	■	■	■	■	■	■	■	■	■	
7	ARI-SAFE-12903, DN32/50, PN16, EN-JL1040 6b	7 747 434 991	■	■	■	■	■	■	■	■	■	■	■	■	Zubehör
8	Fed-Sicherh-Vent GG Wei DN32/50 4,0bar	8 264 356 6	■	■	■	■	■	■	■	■	■	■	■	■	Zubehör
9	SAFE-12903 GG weichd. DN32/50 5,0bar	8 264 357 0	■	■	■	■	■	■	■	■	■	■	■	■	Zubehör
10	Verteiler R1 90-120 everp	7 747 007 722	■	■								■	■		
10	Verteiler R11/4 160-280 everp	7 747 007 723				■									
11	Verteiler R11/4 160-280 everp	7 747 007 723			■	■	■	■	■	■	■				
11	Logafix Membran-Sicherheitsv.1 1/4" 3bar	8 080 503 6				■									Zubehör
12	Logafix Membran-Sicherheitsv.1 1/4" 3bar	8 080 503 6	■	■	■		■	■	■	■	■	■	■	■	Zubehör
16	Manometer 2,5bar 63mm AE D3/8"U	8 119 203 0	■	■	■	■	■	■	■	■	■	■	■	■	Zubehör

KB372
75 - 300kW

Anschlußteile
Connection parts
Raccordement
Collegamento
Aansluiting
Conexión

4

Ersatzteilliste
Spare parts list

Liste des pièces de rechange
Lista parti di ricambio

Onderdelenlijst
Lista de repuestos

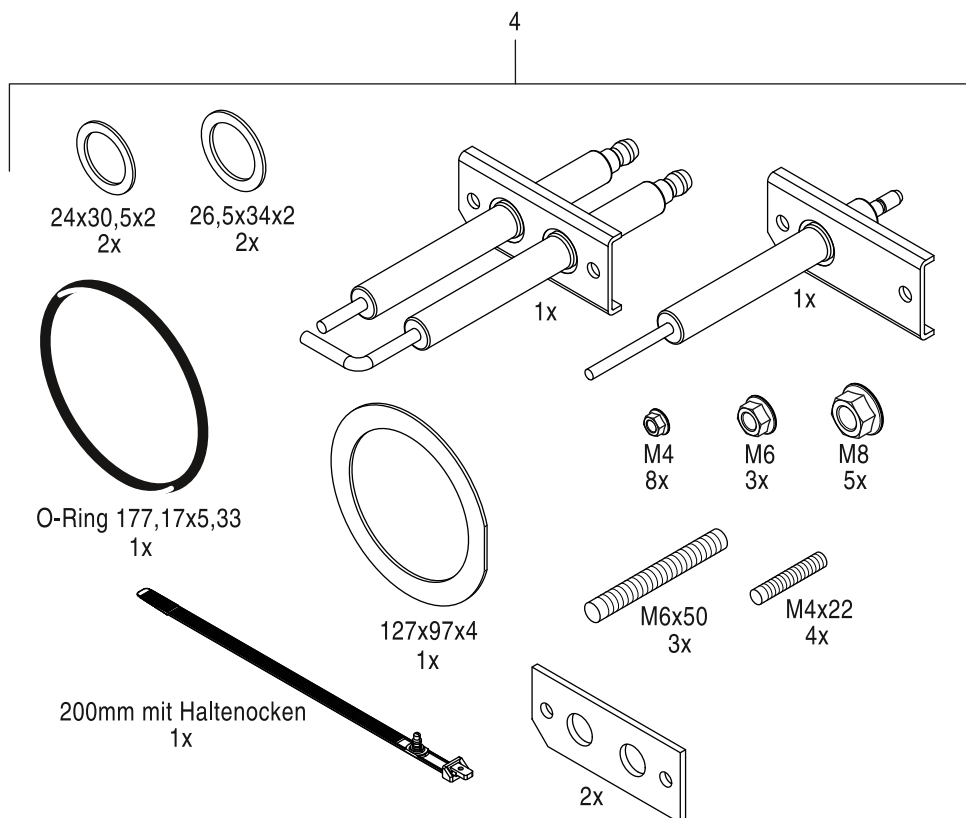
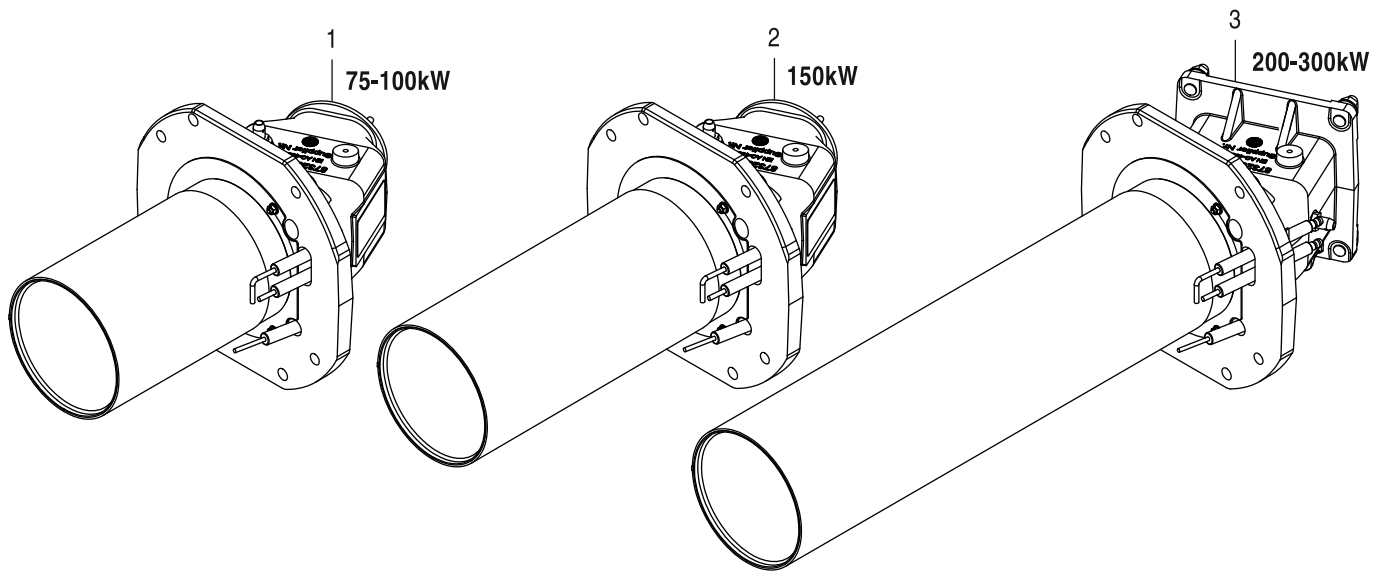

8738894544.ac.RO

5A
Brennereinheit
Burner unit
Unité de brûleur
Gruppo bruciatore
Brander eenheid
Quemador

KB372
75 - 300kW

Pos	Bezeichnung Description Dénomination Descrizioni Benaming Descripción	Bestell-Nr. Ordering no. Numéro de commande N° d'ordine Bestelnummer Número el ordenar	KB372-100/3 li	KB372-100/3 re	KB372-150/4 li	KB372-150/4 re	KB372-200/5 li	KB372-200/5 re	KB372-250/6 li	KB372-250/6 re	KB372-300/7 li	KB372-300/7 re	KB372-75/3 li	KB372-75/3 re	Bemerkungen Remarks Remarques Osservazioni Opmerkingen Observaciones
1	Brennereinheit 75 & 100 kW everp	8 738 805 223	■	■									■	■	
2	Brennereinheit 150 kW everp	8 738 805 224			■	■									
3	Brennereinheit 200 kW everp	8 738 805 225					■	■							
3	Brennereinheit 250 kW everp	8 738 805 226							■	■					
3	Brennereinheit 300 kW everp	8 738 805 227									■	■			
4	Service Set KB372 / Condens 7000F everp	8 738 805 303	■	■	■	■	■	■	■	■	■	■	■	■	

KB372
75 - 300kW

Brennereinheit
Burner unit
Unité de brûleur
Gruppo bruciatore
Brander eenheid
Quemador

5A

Ersatzteilliste
Spare parts list

Liste des pièces de rechange
Lista parti di ricambio

Onderdelenlijst
Lista de repuestos

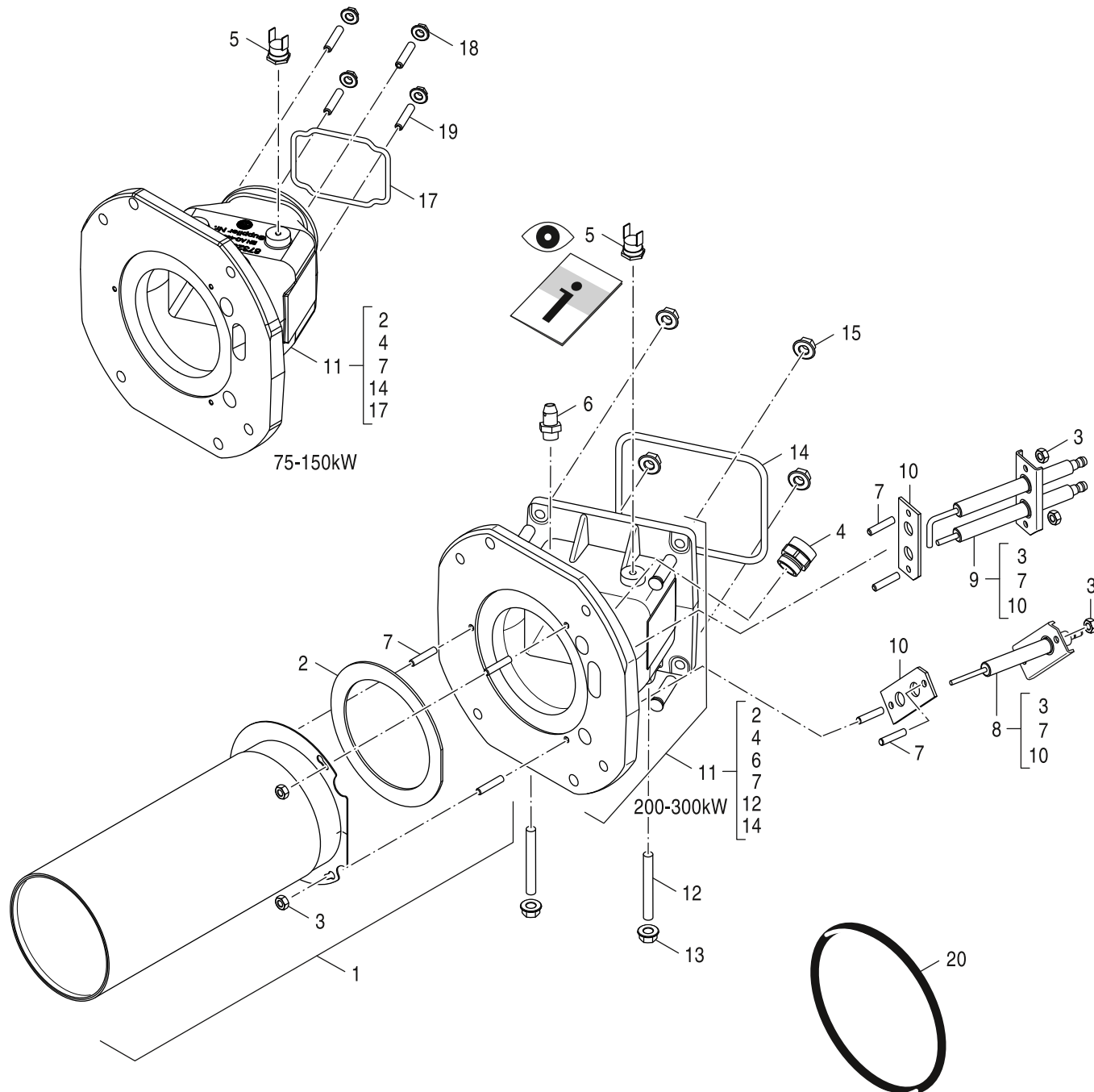

8738894151.ae.RO

5B
Brennstab/Mischeinrichtung
Burner rod
Rampe de combustion
Torcia del bruciatore
Staafterander
Barra combustibile

KB372
75 - 300kW

Pos	Bezeichnung Description Dénomination Descrizioni Benaming Descripción	Bestell-Nr. Ordering no. Numéro de commande N° d'ordine Bestelnummer Número el ordenar	KB372-100/3 li	KB372-100/3 re	KB372-150/4 li	KB372-150/4 re	KB372-200/5 li	KB372-200/5 re	KB372-250/6 li	KB372-250/6 re	KB372-300/7 li	KB372-300/7 re	KB372-75/3 li	KB372-75/3 re	Bemerkungen Remarks Remarques Osservazioni Opmerkingen Observaciones
1	Brennstab d114,8 - L367,4 (200kW) everp	8 738 804 985					■	■							
1	Brennstab d114,8 - L185,4 (100kW) everp	8 738 804 986	■	■									■	■	
1	Brennstab d114,8 - L276,4 (150kW) everp	8 738 804 987			■	■									
1	Brennstab d114,8 - L465,4 (250kW) everp	8 738 804 988							■	■					
1	Brennstab d114,8 - L556,4 (300KW) everp	8 738 804 989									■	■			
2	Dichtung Brennstab VM G-Unit everp	8 738 804 969	■	■	■	■	■	■	■	■	■	■	■	■	
3	6kt-Mutter M4 (10x) everp	8 738 804 990	■	■	■	■	■	■	■	■	■	■	■	■	
4	Schauglas M16x1 kpl everp	8 718 589 884	■	■	■	■	■	■	■	■	■	■	■	■	
5	Bimetallschalter 130°C everp	7 736 606 113	■	■	■	■	■	■	■	■	■	■	■	■	
6	Druckmessdüse G1/8" everp	8 718 584 783	■	■	■	■	■	■	■	■	■	■	■	■	
7	Gewindestifte M4 x 22 (10x) everp	8 738 804 991	■	■	■	■	■	■	■	■	■	■	■	■	
8	Überwachungselektrode VM G-Unit everp	8 738 804 966	■	■	■	■	■	■	■	■	■	■	■	■	
9	Zündelektrode VM G-Unit everp	8 738 804 967	■	■	■	■	■	■	■	■	■	■	■	■	
10	Dichtung Elektrode (2x) everp	8 718 583 001	■	■	■	■	■	■	■	■	■	■	■	■	
11	Gemischkrümmer VM G-Unit 75-150 kW everp	7 736 604 143	■	■	■								■	■	
11	Gemischkrümmer VM G-Unit 200-300kW everp	8 738 804 973					■	■	■	■	■				
12	Gewindebolzen M6 x 50 (6x) everp	8 738 805 024					■	■	■	■	■				
13	Mutter M6 EN 1661 - 8.8 A3K everp (10x)	8 738 805 028	■	■	■	■	■	■	■	■	■	■	■	■	
14	O-Ring 134,08x109,08x5,33 mm (3x) everp	8 738 804 968	■	■	■	■	■	■	■	■	■	■	■	■	
15	Mutter M8 EN 1661 (10x) everp	8 738 805 025	■	■	■	■	■	■	■	■	■	■	■	■	
17	Formdichtung 67,4x 67,4x 3 mm (3x) everp	8 738 804 992	■	■	■								■	■	
18	6kt-Mutter -M5-A2-70 sperrv(10 St) everp	7 736 602 864	■	■	■								■	■	
19	Gewindestift M5 x 25 mm (10x) everp	8 738 804 993	■	■	■								■	■	
20	O-ring ISO3601-1-365B-177,17x5,33 everp	8 738 804 597	■	■	■	■	■	■	■	■	■	■	■	■	

KB372
75 - 300kW

Brennstab/Mischeinrichtung
Burner rod
Rampe de combustion
Torcia del bruciatore
Staafrander
Barra combustible

5B

Ersatzteilliste
Spare parts list

Liste des pièces de rechange
Lista parti di ricambio

Onderdelenlijst
Lista de repuestos

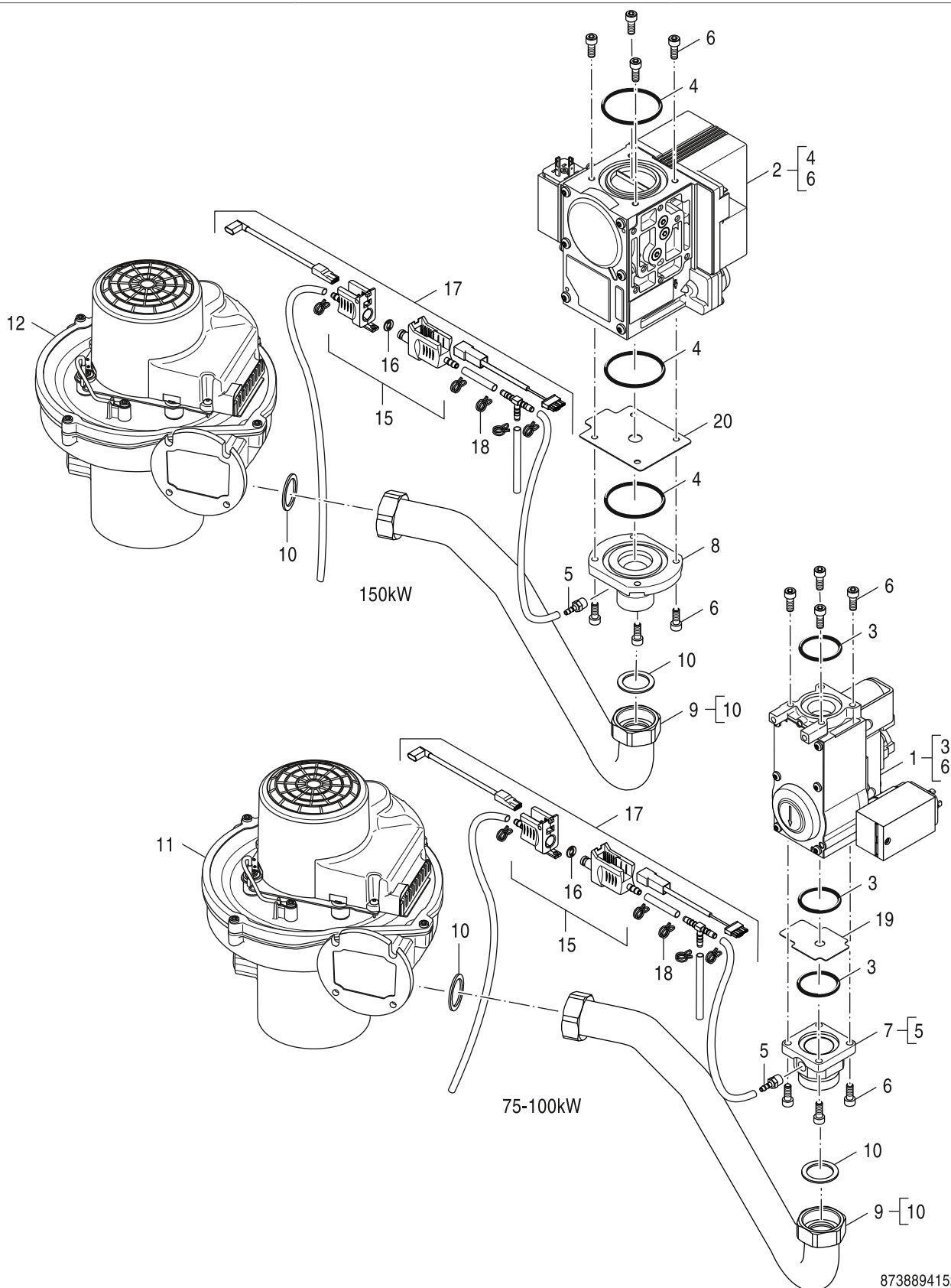

8738894152.aa.RO

6A

Gebälse / Gasarmatur Gr. 75-150
fan / gas valve Gr. 75-150
ventilateur / bloc gaz Gr. 75-150
ventilatore / valvola del gas Gr. 75-150
ventilator / gasregelblok Gr. 75-150
ventilador / válvula del gas Gr. 75-150

KB372
75 - 300kW

Pos	Bezeichnung Description Dénomination Descrizioni Benaming Descripción	Bestell-Nr. Ordering no. Numéro de commande N° d'ordine Bestelnummer Número el ordenar	KB372-100/3 li	KB372-100/3 re	KB372-150/4 li	KB372-150/4 re	KB372-200/5 li	KB372-200/5 re	KB372-250/6 li	KB372-250/6 re	KB372-300/7 li	KB372-300/7 re	KB372-75/3 li	KB372-75/3 re	Bemerkungen Remarks Remarques Osservazioni Opmerkingen Observaciones
1	Gasarmatur VR 4615 (100 kW) everp	8 738 804 994	■	■											
1	Gasarmatur VR 4615 (75 kW) everp	8 738 805 621										■	■		
2	Gasarmatur VR 415 everp	7 736 604 037			■	■									
3	Dichtung 33x24x3,5 (10x)	8 718 600 283	■	■								■	■		
4	O-Ring 52,39x3,53	6 303 606 5			■	■									
5	Einschraubstutzen NW4XR1/8 gerade(3x)everp	7 736 602 861	■	■	■	■						■	■		
6	Zylinderschraube DIN 912 M5x16 (8x)	6 304 009 5	■	■	■	■						■	■		
7	Flansch VR4615 everp	8 738 804 980	■	■								■	■		
8	Flansch VR4XX 1" everp	8 738 804 972			■	■									
9	Flexrohr DN20 CLA-1 everp	8 738 804 975	■	■	■	■						■	■		
10	Dichtung D24x30,5x2 AFM34 (1x) everp	8 718 585 269	■	■	■	■						■	■		
11	Gebläse EBM NRG-137 - 75-100 kW everp	8 738 805 004	■	■								■	■		
12	Gebläse EBM NRG-137 - 150 kW everp	8 738 805 005			■	■									
15	Stecker VM G-Unit 75-300 everp	8 738 805 013	■	■	■	■						■	■		
16	O-Ring 6,07 x 1,78 (5x) everp	8 738 805 031	■	■	■	■						■	■		
17	Kompensationsleitung everp	8 738 805 014	■	■	■	■						■	■		
18	Schlauchsicherung (Klammer) (10x) everp	8 738 805 015	■	■	■	■						■	■		
19	Gasblende VR4615 D=8,70 mm everp	8 738 805 026	■	■								■	■		
19	Gasblende VR4615 D=9,90 mm everp	8 738 805 027	■	■								■	■		
20	Gasdrossel VR46XX D=9,80 mm everp	7 736 603 999	■	■								■	■		
20	Gasdrossel VR4XX D=20,00 mm everp	7 736 604 025			■	■									
20	Gasdrossel VR46XX D=6,80 mm everp	7 736 604 029	■	■								■	■		
20	Gasdrossel VR4XX D = 8,50 mm everp	7 736 604 041			■	■									
20	Gasdrossel VR4XX D = 12,30 mm everp	8 738 805 016			■	■									
20	Gasdrossel VR4XX D = 21,00 mm everp	8 738 805 017			■	■									

KB372
75 - 300kW

Gebläse / Gasarmatur Gr. 75-150
fan / gas valve Gr. 75-150
ventilateur / bloc gaz Gr. 75-150
ventilatore / valvola del gas Gr. 75-150
ventilator / gasregelblok Gr. 75-150
ventilador / válvula del gas Gr. 75-150

6A

Ersatzteilliste
Spare parts list

Liste des pièces de rechange
Lista parti di ricambio

Onderdelenlijst
Lista de repuestos

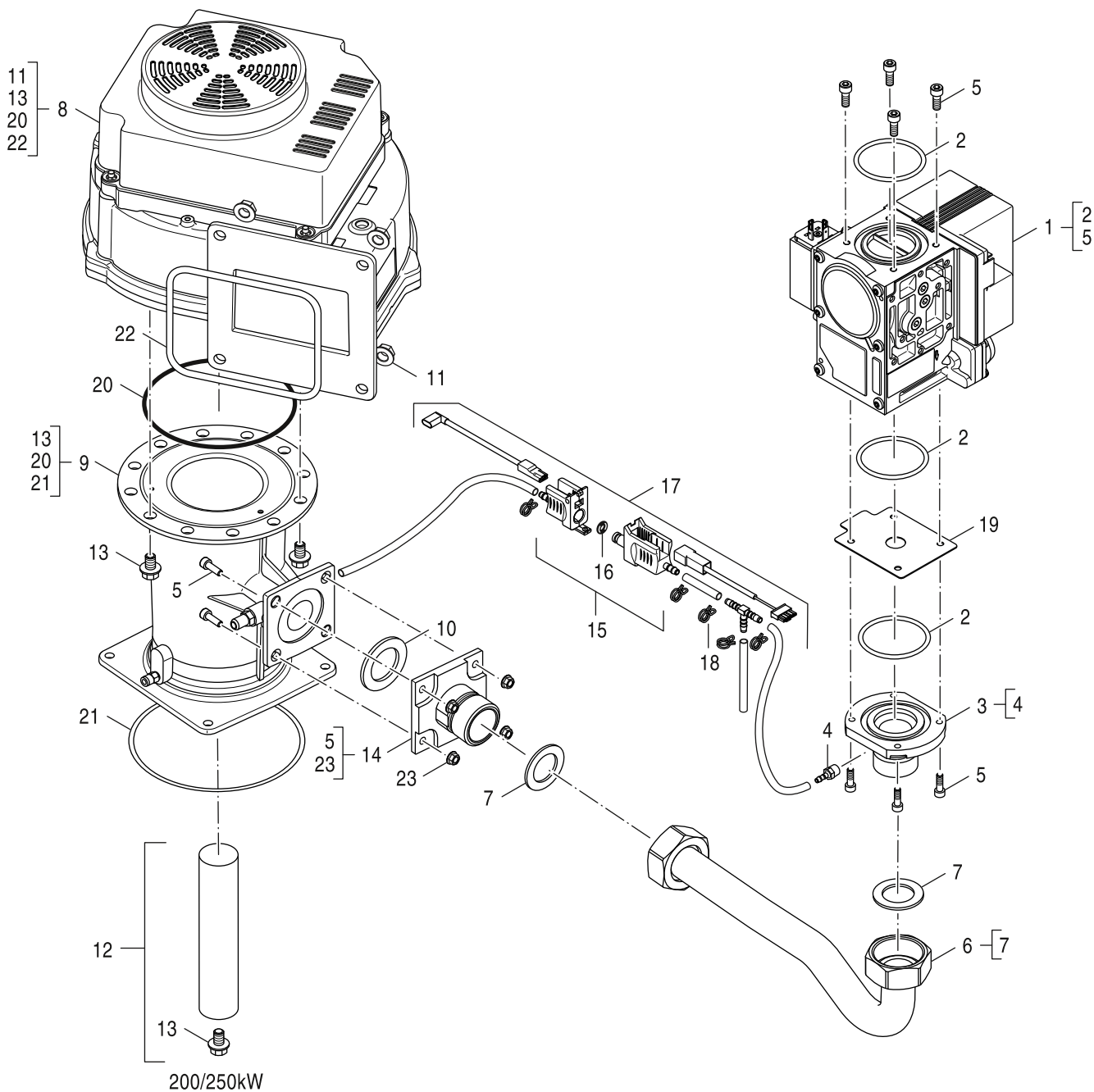

8738894153.aa.RO

6B

Gebläse / Gasarmatur Gr. 200-300
fan / gas valve Gr. 200-300
ventilateur / bloc gaz Gr. 200-300
ventilatore / valvola del gas Gr. 200-300
ventilator / gasregelblok Gr. 200-300
ventilador / válvula del gas Gr. 200-300

KB372
75 - 300kW

Pos	Bezeichnung Description Dénomination Descrizioni Benaming Descripción	Bestell-Nr. Ordering no. Numéro de commande N° d'ordine Bestelnummer Número el ordenar	KB372-100/3 li	KB372-100/3 re	KB372-150/4 li	KB372-150/4 re	KB372-200/5 li	KB372-200/5 re	KB372-250/6 li	KB372-250/6 re	KB372-300/7 li	KB372-300/7 re	KB372-75/3 li	KB372-75/3 re							Bemerkungen Remarks Remarques Osservazioni Opmerkingen Observaciones	
1	Gasarmatur VR 420 (200 kW) everp	7 736 604 038					■	■														
1	Gasarmatur VR 420 (250 kW) everp	7 736 604 039							■	■												
1	Gasarmatur VR 425 everp	7 736 604 040										■	■									
2	O-Ring 52,39x3,53	6 303 606 5					■	■	■	■	■	■										
3	Flansch VR4XX 1 1/8" everp	8 738 804 971					■	■	■	■	■	■										
4	Einschraubstutzen NW4XR1/8 gerade(3x)everp	7 736 602 861					■	■	■	■	■	■										
5	Zylinderschraube DIN 912 M5x16 (8x)	6 304 009 5					■	■	■	■	■	■										
6	Flexrohr DN25 CLA-1 everp	8 738 804 976					■	■	■	■	■	■										
7	Dichtungs-Set D27x38x2mm (5x) everp	7 747 031 431					■	■	■	■	■	■										
8	Gebälse EBM G1G170 everp	8 738 804 981					■	■	■	■	■	■										
9	Venturi VMU 185 everp	8 738 805 022					■	■														FD<02/2020
9	Venturi VMU 300 everp	8 738 805 023					■	■	■	■	■	■										
10	Dichtung Venturi everp	6 304 017 9					■	■	■	■	■	■										
11	Mutter M8 EN 1661 (10x) everp	8 738 805 025					■	■	■	■	■	■										
12	Luftdrossel D20 everp	6 303 609 2								■	■											
12	Luftdrossel D27 everp	7 736 604 033					■	■														
13	6kt-Schrauben M8x12 8Stck mverp	7 747 016 175					■	■	■	■	■	■										
14	Flansch G 1 1/8" everp	8 738 805 018					■	■	■	■	■	■										
15	Stecker VM G-Unit 75-300 everp	8 738 805 013					■	■	■	■	■	■										
16	O-Ring 6,07 x 1,78 (5x) everp	8 738 805 031					■	■	■	■	■	■										
17	Kompensationsleitung everp	8 738 805 014					■	■	■	■	■	■										
18	Schlauchsicherung (Klammer) (10x) everp	8 738 805 015					■	■	■	■	■	■										
19	Gasdrossel VR4XX D=18,00 mm everp	7 736 604 026					■	■														
19	Gasdrossel VR4XX D=25,40 mm everp	7 736 604 027								■	■											
19	Gasdrossel VR4XX D=25,20 mm everp	7 736 604 028										■	■									
19	Gasdrossel VR4XX D = 10,30 mm everp	7 736 604 042					■	■														
19	Gasdrossel VR4XX D = 11,30 mm everp	7 736 604 043								■	■											
19	Gasdrossel VR4XX D = 12,10 mm everp	7 736 604 044										■	■									
19	Gasdrossel VR4XX D = 14,40 mm everp	8 738 805 006					■	■														
19	Gasdrossel VR4XX D = 19,00 mm everp	8 738 805 007					■	■														
19	Gasdrossel VR4XX D = 16,30 mm everp	8 738 805 008								■	■											
19	Gasdrossel VR4XX D = 25,60 mm everp	8 738 805 009								■	■											
19	Gasdrossel VR4XX D = 17,30 mm everp	8 738 805 010										■	■									
19	Gasdrossel VR4XX D = 26,00 mm everp	8 738 805 011										■	■									
20	O-Ring 110,0 x 3,2 mm everp (3x)	8 738 805 012					■	■	■	■	■	■										
21	Dichtung VMU (3x) everp	8 738 804 984					■	■	■	■	■	■										
22	O-Ring 134,08x109,08x5,33 mm (3x) everp	8 738 804 968					■	■	■	■	■	■										
23	6kt-Mutter EN1663 -M5 -8 sw (10x) everp	7 736 602 865					■	■	■	■	■	■										
KB372 75 - 300kW															Gebälse / Gasarmatur Gr. 200-300 fan / gas valve Gr. 200-300 ventilateur / bloc gaz Gr. 200-300 ventilatore / valvola del gas Gr. 200-300 ventilator / gasregelblok Gr. 200-300 ventilador / válvula del gas Gr. 200-300						6B	

Ersatzteilliste
Spare parts list

Liste des pièces de rechange
Lista parti di ricambio

Onderdelenlijst
Lista de repuestos

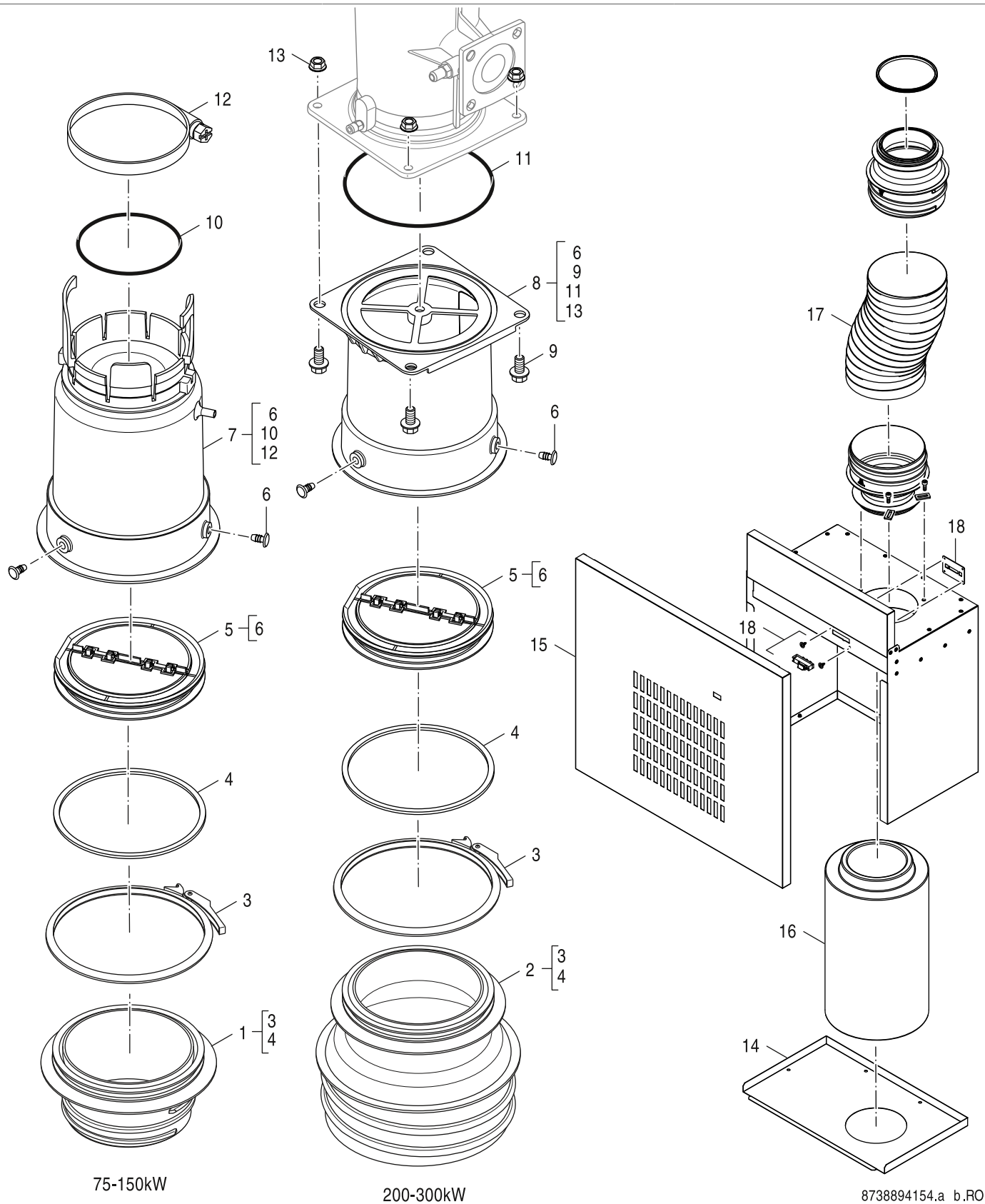

75-150kW

200-300kW

8738894154.a b.RO

7

Ansaugadapter NRG/VMU
Adaptor suction NRG/VMU
Raccord NRG/VMU
Adapter NRG/VMU
Adaptador NRG/VMU
Adattore NRG/VMU

KB372
75 - 300kW

Pos	Bezeichnung Description Dénomination Descrizioni Benaming Descripción	Bestell-Nr. Ordering no. Numéro de commande N° d'ordine Bestelnummer Número el ordenar	KB372-100/3 li	KB372-100/3 re	KB372-150/4 li	KB372-150/4 re	KB372-200/5 li	KB372-200/5 re	KB372-250/6 li	KB372-250/6 re	KB372-300/7 li	KB372-300/7 re	KB372-75/3 li	KB372-75/3 re	Bemerkungen Remarks Remarques Osservazioni Opmerkingen Observaciones
1	RLU-Adapter DN110 everp	8 738 805 002	■	■	■										
2	RLU-Adapter DN160 everp	8 738 804 982					■	■	■	■	■				
3	Spannschelle d=140 mm everp	8 738 805 003	■	■	■	■	■	■	■	■	■	■	■		
4	Dichtung Di=122 RLU (3x) everp.	8 738 804 970	■	■	■	■	■	■	■	■	■	■	■		
5	Luftklappe VM G-Unit everp	8 738 804 974	■	■	■	■	■	■	■	■	■	■	■		
6	Stopfen Luftklappe (10x) everp	8 738 804 979	■	■	■	■	■	■	■	■	■	■	■		
7	Ansaugadapter NRG everp	8 738 804 977	■	■	■							■	■		
8	Ansaugadapter VMU 200 kW everp	7 736 602 863					■	■							FD<02/2020
8	Ansaugadapter VMU everp	8 738 804 978					■	■	■	■	■				
9	6kt-Schraube M6x12 ISO4017 (10x) everp	8 738 805 029					■	■	■	■	■				
10	Dichtung Adapter NRG (3x) everp	8 738 805 000	■	■	■							■	■		
11	Dichtung VMU (3x) everp	8 738 804 984					■	■	■	■	■				
12	Schlauschelle NRG (3x) everp	8 738 805 001	■	■	■							■	■		
13	Mutter M6 EN 1661 - 8.8 A3K everp (10x)	8 738 805 028					■	■	■	■	■				
14	Luftfilterkastendeckel everp	7 736 604 031	■	■	■	■	■	■	■	■	■	■	■		
15	Vorderwand Luftkasten everp	7 736 604 030	■	■	■	■	■	■	■	■	■	■	■		
16	Luftfilter D220x404 mm everp	7 736 604 035	■	■	■	■	■	■	■	■	■	■	■		
17	Schlauch DN160-450 mm everp	7 736 604 032	■	■	■	■	■	■	■	■	■	■	■		
18	Füllstandsanzeige everp	7 736 604 034	■	■	■	■	■	■	■	■	■	■	■		

KB372
75 - 300kW

Ansaugadapter NRG/VMU
Adaptor suction NRG/VMU
Raccord NRG/VMU
Adapter NRG/VMU
Adaptador NRG/VMU
Adattore NRG/VMU

7

Ersatzteilliste
Spare parts list

Liste des pièces de rechange
Lista parti di ricambio

Onderdelenlijst
Lista de repuestos

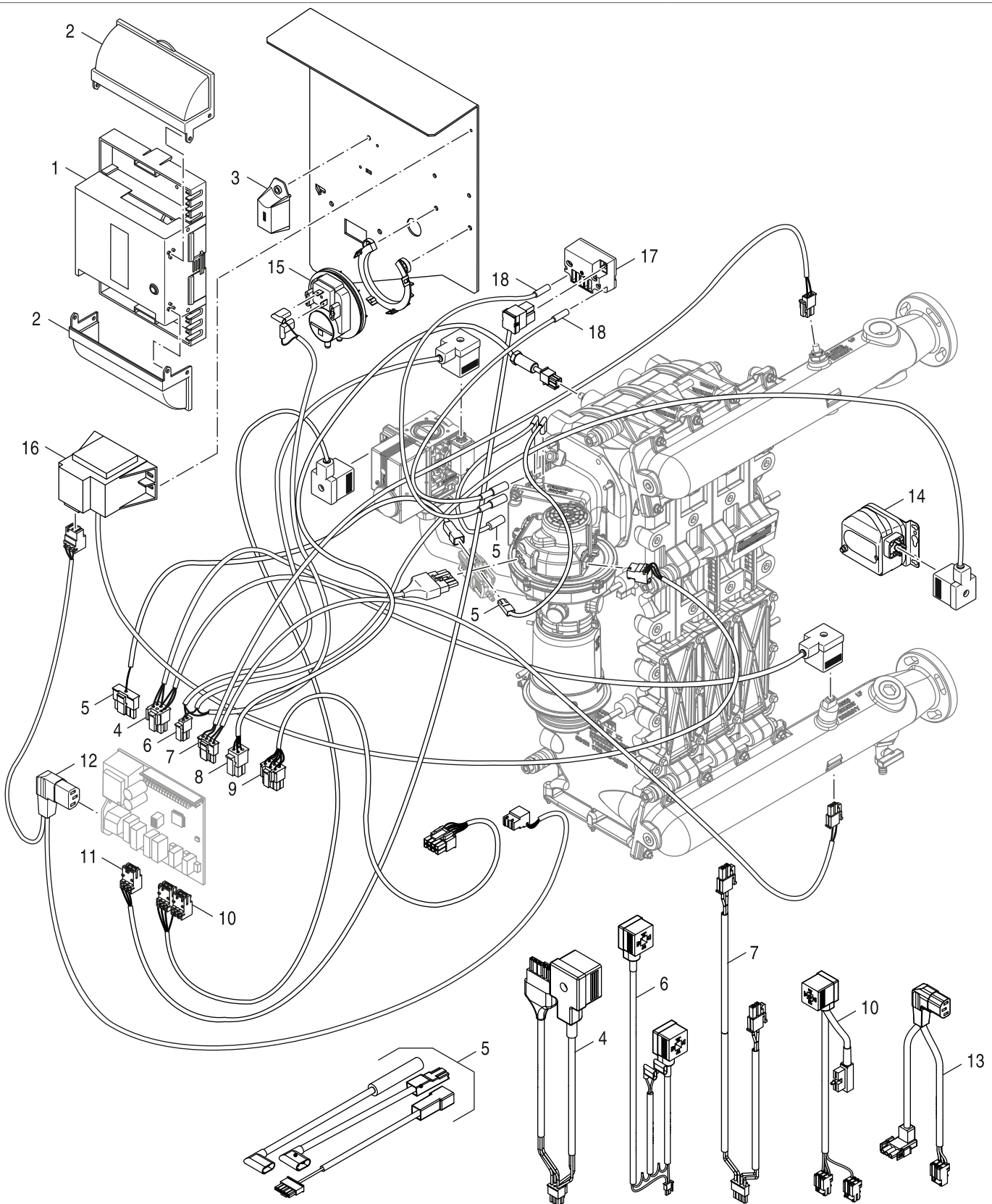

8738894155.aa.RO

8

SAFe 44
SAFe 44
SAFe 44
SAFe 44
SAFe 44

KB372
75 - 300kW

Pos	Bezeichnung Description Dénomination Descrizioni Benaming Descripción	Bestell-Nr. Ordering no. Numéro de commande N° d'ordine Bestelnummer Número el ordenar											Bemerkungen Remarks Remarques Osservazioni Opmerkingen Observaciones		
			KB372-100/3 li	KB372-100/3 re	KB372-150/4 li	KB372-150/4 re	KB372-200/5 li	KB372-200/5 re	KB372-250/6 li	KB372-250/6 re	KB372-300/7 li	KB372-300/7 re		KB372-75/3 li	KB372-75/3 re
1	SAFE 44 V3 everp	8 738 807 851	■	■	■	■	■	■	■	■	■	■			
2	Gehäuse Klemmenabdeckung SAFe everp	6 302 392 5	■	■	■	■	■	■	■	■	■	■			
3	Modul BIM44 6501-V5 KB372-75 everp	7 736 604 065										■	■		Nur für Service-Techniker
3	Modul BIM44 6502-V5 KB372-100 everp	7 736 604 066	■	■											Nur für Service-Techniker
3	Modul BIM44 6503-V5 KB372-150 everp	7 736 604 067			■	■									Nur für Service-Techniker
3	Modul BIM44 6504-V5 KB372-200 everp	7 736 604 068					■	■							Nur für Service-Techniker
3	Modul BIM44 6505-V5 KB372-250 everp	7 736 604 069							■	■					Nur für Service-Techniker
3	Modul BIM44 6506-V5 KB372-300 everp	7 736 604 070								■	■				Nur für Service-Techniker
4	Verb.L. GebL. PWM WIDW 900/2740 everp	8 738 805 139	■	■	■	■						■	■		
4	Verb.L. GebL. WM WIDW 920/3300 everp	8 738 805 141					■	■	■	■	■				
5	Verbindungsleitg Ionisation kpl everp	8 738 805 144	■	■	■	■	■	■	■	■	■	■	■		
6	Verb.L. Druckwächter 3Y 290/2600 everp	8 738 805 143			■	■	■	■	■	■	■				
6	Verb.L. Druckwächter 3Y 290/760 everp	8 738 805 148	■	■								■	■		
7	Verb.L. Vor/Rüchl. f. 1450/2600 everp	8 738 805 140	■	■	■	■						■	■		
7	Verb.L. Vor/Rüchl. f. 2000/3450 everp	8 738 805 142					■	■	■	■	■				
8	Verbindungsitg Kesselfüh SAFeTülle everp	6 303 921 1	■	■	■	■	■	■	■	■	■	■	■		
9	Datenleitung SAFe MC10 BE everp	6 303 015 0	■	■	■	■	■	■	■	■	■	■	■		
10	Verbindungsleitung MV1 MV2 1300 everp	8 738 805 138			■	■	■	■	■	■	■				
10	Verbindungsleitung MV1 MV2 1100 everp	8 738 805 147	■	■								■	■		
11	Verb.L. SAFe - Zündung 1200 everp	8 738 805 145	■	■	■	■	■	■	■	■	■	■	■		
12	Y- Kabel SAFe Gebläse 980/650 everp	8 738 805 137	■	■	■	■						■	■		
13	Y- Kabel SAFe Gebläse 1400/1100 everp	8 738 805 146					■	■	■	■	■				
14	Druckschalter DL10KH-5WZ everp	8 738 805 150	■	■								■	■		
14	Druckschalter DL10KH-5WZ 9,5 everp	8 738 806 365			■	■	■	■	■	■	■				
15	Druckschalter Typ 605 23/15Pa kpl everp	8 738 805 149	■	■	■	■	■	■	■	■	■	■	■		
16	Drossel für NRG137 everp	8 738 805 156	■	■	■							■	■		
17	Zünderinrichtung Danfoss EBI V4 everp	8 718 575 099 0	■	■	■	■	■	■	■	■	■	■	■		
18	Zündkabel KD7 SD6,3 SD4 everp	6 304 009 4	■	■	■	■	■	■	■	■	■	■	■		

KB372
75 - 300kW

SAFe 44
SAFe 44
SAFe 44
SAFe 44
SAFe 44
SAFe 44

8

Übersetzungsliste List of translations		Liste des traductions Traduzione delle descrizioni		Vertalinglijst Lista de traducciones	
Pos	Description	Denomination	Descrizione	Benaming	Descripción
1A	Element of construction	Groupe de construction	Gruppo di costruzione	Montagegroep	Grupo de construcción
1	Boiler Block CLA-1 3sec (r) everp	Bloc chaudi#re 3sec (r)	Corpo caldaia 3sec (r)	Ketelblok 3sec (r)	Cuerpo de caldera 3sec (r)
1	Boiler Block CLA-1 3sec (l) sp	Bloc chaudi#re 3sec (l)	Corpo caldaia 3sec (l)	Ketelblok 3sec (l)	Cuerpo de caldera 3sec (l)
2	Red-nipple Rp 3/4xG1/4 MS	Nipple de réduction Rp 3/4"xG1/4" (MS)	Nipplo riduttore Rp 3/4"xG1/4" (MS)	Reductienippel Rp 3/4"xG1/4" GB312	Casquillo acoplamiento de sonda
3	Sensor boiler G1/4 45mm sp	Sonde chaudiere g1/4 45mm	Sonda Caldaia G1/4 45mm	Ketelvoeler G(B)135 G1/4 45mm	Sensor de caldera G1/4 45mm
4	Seal O-Ring 53,34 x 5,33 (14x) sp	Joint torique 53,34x5,33 (14x)	O-ring 53,34x5,33 (14x)	O-ring 53,34x5,33 (14x)	Anillo tórico 53,34x5,33 (14x)
5	Manifold CLA-1 3sec sp	Tube retour CLA-1 3sec	Tubazione di ritorno CLA-1 3sec	Retourleiding CLA-1 3sec	Tubo de retorno CLA-1 3sec
6	Washer ISO 7089 A8,4 A3K (10x)	Rondelle ISO 7089 A8,4 A3K (10x)	Rondella ISO 7089 A8,4 A3K (10x)	Onderlegging ISO 7089 A8,4 A3K (10x)	Arandela ISO 7089 A8,4 A3K (10x)
7	Hexagon nut DIN6923 M8 A3K (10x)	Ecrou hexagonal DIN6923 M8 A3K (10x)	Dado esagonale DIN6923 M8 A3K (10x)	Zeskantmoer DIN6923 M8 A3K (10x)	Tuerca hexagonal DIN6923 M8 A3K (10x)
8	Cap GPN800 G2"PP yellow everp	Capuchon	tappo G2" PP	Kap G2"PP	Tapa G2" PP
9	Seal D60x45x2 Viton everp	Joint D60x45x2 Viton	Guarnizione D60x45x2 Viton	Pakking D60x45x2 Viton	Junta D60x45x2 Viton
10	Gasket insp. cover block CLA-1 (2x)	Joint trappe de visite (2x)	Guarnizione coperchio di pulizia (2x)	Pakking reinigingsdeksel (2x)	Junta tapa de limpieza (2x)
11	Cover inspection CLA-1 sp	Trappe de visite bloc	Coperchio di pulizia blocco	Reinigingsdeksel blok	Tapa de limpieza bloque
12	Nut M6 (8x)	Ecrou hexagonal M6	Dado esagonale M6	Zeskantmoer	Tuerca M6
13	Reducer 1/2x1/4	Réduction 1/2x1/4	Riduzione 1/2x1/4	Reduceerstuk 1/2"x1/4	Manguito de reducción 1/2x1/4
14	SENSOR G1/4 45mm sp	Sonde temperature G1/4 45mm	SENSOR G1/4 45mm	Voeler G1/4 45mm	Sensor individual G1/4 45mm
15	Socket R1/2xG3/8 with seal	Réduction	Riduzione	Verloopnippel	Llave R1/2"xG3/8" con sellador
16	Pressure-Transmitter Typ503 sp	Transmetteur de pression Typ503	Trasmettitore di pressione Typ503	Drukopnemer Typ503	Transmisor de presión Typ 503
17	Reservoir condensate CLA-1 3sec everp	Réservoir # condensats 3sec	Vaschetta di raccolta della condensa 3se	Condensbak 3sec	Depósito de condensados 3sec
21	Lipseal DN110, peroxide set (5x)	Joint # l#vres, peroxyde, DN110 (5 pcs.	Guarnizione di peroxyd DN110 (5x)	Lippendichting DN110, peroxide set (5x)	Sello DN110 , set de peróxido (5x)
22	Sample point cap	Capot de protection	Calotta	Beschermkap	Capuchón protector
25	Drain_cock R1/2	Robinet R1/2 Bekaert 048-250 embf	Rubin. KFE R1/2 Bekaert 048-250 imball.	Drain_cock R1/2	Llave de llenado y vaciado R1/2
26	Syphon	SIPHON	Sifone	Sifon	Sifon
27	Sealing (5x)	Joint DN 18 (5x)	Guarn. anello con spig. di ten. DN18(5x)	Dichtingsring (5x)	Junta DN18 (5x)
28	Pipe drain	Évacuation des condensats	Scarico condensa	Condensafvoer	Drenaje de condensado
29	Silicone Wezilit EV-300 red to 300°C	Silicone Wezilit EV-300 rouge 300°C	Silicone Wezilit EV-300 rosso sino 300°C	Silicone Wezilit EV-300 rood tot 300°C	Silikon Wezilit EV-300rot bis 300°Ceverp
30	Nut PG29	Contre-écrou	Controdado	Borgmoer	Contratuerca
31	Lip seal 29,8 x 6,1 (5x)	Joint 29,8 x 6,1 (5x)	Guarnizione 29,8 x 6,1 (5x)	Lipring 29,8 x 6,1 (5x)	Junta 29,8 x 6,1 (5x)
32	Seal O-ring 177,17x5,33 sp	JOINT TORIQUE NITRILE DIA.17x5,33	Anello di tenuta 17x5,33	O-Ring 17x5,33	Anillo tórico 17x5,33
33	Gasket D33x44x2mm	Joint D33x44x2mm	Guarnizione	Pakking	Junta
34	Plug G 1	BOUCHON G1	Tappo	Stop	Tapon G1
35	Foot M10x51 (4x)	Pieds réglables M10x51 (4x)	Piedini regolabili M10x51 (4x)	Voetjes Boiler HP-270-1	Patas regulables M10x51 (4x)

Übersetzungsliste List of translations		Liste des traductions Traduzione delle descrizioni		Vertalinglijst Lista de traducciones	
Pos	Description	Denomination	Descrizione	Benaming	Descripción
1B	Element of construction	Groupe de construction	Gruppo di costruzione	Montagegroep	Grupo de construcción
1	Boiler Block CLA-1 7sec (r) sp	Bloc chaudi#re 7sec (r)	Corpo caldaia 7sec (r)	Ketelblok 7sec (r)	Cuerpo de caldera 7sec (r)
1	Boiler Block CLA-1 6sec (r) sp	Bloc chaudi#re 6sec (r)	Corpo caldaia 6sec (r)	Ketelblok 6sec (r)	Cuerpo de caldera 6sec (r)
1	Boiler Block CLA-1 5sec (r) sp	Bloc chaudi#re 5sec (r)	Corpo caldaia 5sec (r)	Ketelblok 5sec (r)	Cuerpo de caldera 5sec (r)
1	Boiler Block CLA-1 4sec (r) sp	Bloc chaudi#re 4sec (r)	Corpo caldaia 4sec (r)	Ketelblok 4sec (r)	Cuerpo de caldera 4sec (r)
1	Boiler Block CLA-1 7sec (l) sp	Bloc chaudi#re 7sec (l)	Corpo caldaia 7sec (l)	Ketelblok 7sec (l)	Cuerpo de caldera 7sec (l)
1	Boiler Block CLA-1 6sec (l) sp	Bloc chaudi#re 6sec (l)	Corpo caldaia 6sec (l)	Ketelblok 6sec (l)	Cuerpo de caldera 6sec (l)
1	Boiler Block CLA-1 5sec (l) sp	Bloc chaudi#re 5sec (l)	Corpo caldaia 5sec (l)	Ketelblok 5sec (l)	Cuerpo de caldera 5sec (l)
1	Boiler Block CLA-1 4sec (l) sp	Bloc chaudi#re 4sec (l)	Corpo caldaia 4sec (l)	Ketelblok 4sec (l)	Cuerpo de caldera 4sec (l)
2	Red-nipple Rp 3/4xG1/4 MS	Nipple de réduction Rp 3/4"xG1/4" (MS)	Nipplo riduttore Rp 3/4"xG1/4" (MS)	Reductienippel Rp 3/4"xG1/4" GB312	Casquillo acoplamiento de sonda
3	Sensor boiler G1/4 45mm sp	Sonde chaudiere g1/4 45mm	Sonda Caldaia G1/4 45mm	Ketelvoeler G(B)135 G1/4 45mm	Sensor de caldera G1/4 45mm
4	Seal O-Ring 53,34 x 5,33 (14x) sp	Joint torique 53,34x5,33 (14x)	O-ring 53,34x5,33 (14x)	O-ring 53,34x5,33 (14x)	Anillo tórico 53,34x5,33 (14x)
5	Manifold CLA-1 7sec sp	Tube retour 7sec	Tubazione di ritorno 7sec	Retourleiding 7sec	Tubo de retorno 7sec
5	Manifold CLA-1 6sec sp	Tube retour 6sec	Tubazione di ritorno 6sec	Retourleiding 6sec	Tubo de retorno 6sec
5	Manifold CLA-1 5sec sp	Tube retour 5sec	Tubazione di ritorno 5sec	Retourleiding 5sec	Tubo de retorno 5sec
5	Manifold CLA 4sec sp	Tube retour 4sec	Tubazione di ritorno 4sec	Retourleiding 4sec	Tubo de retorno 4sec
6	Washer ISO 7089 A8,4 A3K (10x)	Rondelle ISO 7089 A8,4 A3K (10x)	Rondella ISO 7089 A8,4 A3K (10x)	Onderlegging ISO 7089 A8,4 A3K (10x)	Arandela ISO 7089 A8,4 A3K (10x)
7	Hexagon nut DIN6923 M8 A3K (10x)	Ecrou hexagonal DIN6923 M8 A3K (10x)	Dado esagonale DIN6923 M8 A3K (10x)	Zeskantmoer DIN6923 M8 A3K (10x)	Tuerca hexagonal DIN6923 M8 A3K (10x)
10	Gasket insp. cover block CLA-1 (2x)	Joint trappe de visite (2x)	Guarnizione coperchio di pulizia (2x)	Pakking reinigungsdeksel (2x)	Junta tapa de limpieza (2x)
11	Cover inspection CLA-1 sp	Trappe de visite bloc	Coperchio di pulizia blocco	Reinigungsdeksel blok	Tapa de limpieza bloque
12	Nut M6 (8x)	Ecrou hexagonal M6	Dado esagonale M6	Zeskantmoer	Tuerca M6
13	Reducer 1/2x1/4	Réduction 1/2x1/4	Riduzione 1/2x1/4	Reduceerstuk 1/2"x1/4	Manguito de reducción 1/2x1/4
14	SENSOR G1/4 45mm sp	Sonde temperature G1/4 45mm	SENSOR G1/4 45mm	Voeler G1/4 45mm	Sensor individual G1/4 45mm
15	Socket R1/2xG3/8 with seal	Réduction	Riduzione	Verloopnippel	Llave R1/2"xG3/8" con sellador
16	Pressure-Transmitter Typ503 sp	Transmetteur de pression Typ503	Trasmittitore di pressione Typ503	Drukopnemer Typ503	Transmisor de presión Typ 503
17	Reservoir condensate CLA-1 4sec (r) sp	Réservoir # condensats CLA-1 4sec (r)	Vaschetta di raccolta della condensa CLA	Condensbak CLA-1 4sec (r)	Depósito de condensados CLA-1 4sec (r)
17	Reservoir condensate CLA-1 5sec (r) sp	Réservoir # condensats CLA-1 5sec (r)	Vaschetta di raccolta della condensa CLA	Condensbak CLA-1 5sec (r)	Depósito de condensados CLA-1 5sec (r)
17	Reservoir condensate CLA-1 6sec (r) sp	Réservoir # condensats CLA-1 6sec (r)	Vaschetta di raccolta della condensa CLA	Condensbak CLA-1 6sec (r)	Depósito de condensados CLA-1 6sec (r)
17	Reservoir condensate CLA-1 7sec (r) sp	Réservoir # condensats CLA-1 7sec (r)	Vaschetta di raccolta della condensa CLA	Condensbak CLA-1 7sec (r)	Depósito de condensados CLA-1 7 sec (r)
18	Drain sump CLA-1 sp	Débordement condensat CLA-1	Trabocco condensa CLA-1	Condensoverloop CLA-1	Desbordamiento de condensado CLA-1
19	Gasket inspection cover sump CLA-1 sp	Joint trappe de visite réservoir # conde	Guarnizione coperchio di pul della cond	Pakking reinigungsdeksel condensbak	Junta tapa de limpieza depósito de conde
20	Cover service sump CLA-1 sp	Trappe de visite réservoir # condensats	Coperchio di pulizia vaschetta di raccol	Reinigungsdeksel condensbak CLA-1	Tapa de limpieza depósito de condensados

Übersetzungsliste List of translations		Liste des traductions Traduzione delle descrizioni		Vertalinglijst Lista de traducciones	
Pos	Description	Denomination	Descrizione	Benaming	Descripción
20	Cover service sump CLA-1 200 sp	Trappe de visite réservoir # condens 200	Coperchio di pulizia vaschetta di ra 200	Reinigingsdeksel condensbak 200	Tapa de limpieza depósito de condens 200
21	Lipseal DN160 Centrotherm	JOINT A LEVRES DN160 CENTROTHERM	Guarnizione ad anello con spigolo di ten	Lippendichting DN160 GB312/4-5	Junta DN160 Centrotherm
21	Lipseal DN200 Centrotherm	JOINT A LEVRES DN200 CENTROTHERM	Guarnizione ad anello con spigolo di ten	Lippendichting DN200 GB312/6-7-8	Junta DN200 Centrotherm
22	Sample point cap	Capot de protection	Calotta	Beschermkap	Capuchón protector
25	Drain_cock R1/2	Robinet R1/2 Bekaert 048-250 embf	Rubin. KFE R1/2 Bekaert 048-250 imball.	Drain_cock R1/2	Llave de llenado y vaciado R1/2
26	Syphon	SIPHON	Sifone	Sifon	Sifon
27	Resonator CLA-1 200 sp	Résonateur CLA-1 200	Risonatore CLA-1 200	Resonator CLA-1 200	Resonador CLA-1 200
28	Elbow 87° DN160 sp	Coude des fumées DN160	Curva del condotto gas combusti DN160	Rookgasafvoerbocht 87° DN160	Codo de gas de escape 87° DN160
28	Elbow 87° DN200 sp	Coude des fumées 87° DN200	Curva del condotto gas combusti 87°DN200	Rookgasafvoerbocht 87° DN200	Codo de gas de escape 87° DN200
29	Silicone Wezilit EV-300 red to 300°C	Silicone Wezilit EV-300 rouge 300°C	Silicone Wezilit EV-300 rosso sino 300°C	Silicone Wezilit EV-300 rood tot 300°C	Silikon Wezilit EV-300rot bis 300°Ceverp
30	Sealing (5x)	Joint DN 18 (5x)	Guarn. anello con spig. di ten. DN18(5x)	Dichtingsring (5x)	Junta DN18 (5x)
31	Nut PG29	Contre-écrou	Controdado	Borgmoer	Contratuercas
32	Pipe drain	Évacuation des condensats	Scarico condensa	Condensafvoer	Drenaje de condensado
33	Lip seal 29,8 x 6,1 (5x)	Joint 29,8 x 6,1 (5x)	Guarnizione 29,8 x 6,1 (5x)	Lipring 29,8 x 6,1 (5x)	Junta 29,8 x 6,1 (5x)
34	Seal O-ring 177,17x5,33 sp	JOINT TORIQUE NITRILE DIA.17x5,33	Anello di tenuta 17x5,33	O-Ring 17x5,33	Anillo tórico 17x5,33
35	Blanking plug G 1 1/4	Raccord aveugle G 1 1/4	Chiusura cieca G 1 1/4	Blindafsluiting G 1 1/4	Conexión ciega G 1 1/4
36	Foot M10x51 (4x)	Pieds réglables M10x51 (4x)	Piedini regolabili M10x51 (4x)	Voetjes Boiler HP-270-1	Patas regulables M10x51 (4x)
2	Element of construction	Groupe de construction	Gruppo di costruzione	Montagegroep	Grupo de construccion
1	Panel front top CLA-1 BU sp	Panneau avant haut CLA-1 BU	Parete anteriore sopra CLA-1 BU	Voorwand boven CLA-1 BU	Pared delantero arriba CLA-1 BU
2	Panel Hood front CLA-1 75-300 sp	Capot avant CLA-1 75-300	Coperchio anteriore CLA-1 75-300	Afdekkap Voor CLA-1 75-300	Carcasa delante CLA-1 75-300
3	Panel Rear hood CLA-1 75/100 sp	Capot arriere CLA-1 75/100	Coperchio posteriore CLA-1 75/100	Afdekkap Achter CLA-1 75/100	Carcasa detrás CLA-1 75/100
3	Panel Rear hood CLA-1 150 sp	Capot arriere CLA-1 150	Coperchio posteriore CLA-1 150	Afdekkap Achter CLA-1 150	Carcasa detrás CLA-1 150
3	Panel Rear hood CLA-1 200-300 everp	Capot arriere 200-300	Coperchio posteriore 200-300	Afdekkap Achter 200-300	Carcasa detrás 200-300
4	Panel side 569 CLA-1 BU everp	Face latérale arriere 569 CLA-1 BU	Parete laterale posteriore 569 CLA-1 BU	Zijwand Achter 569 CLA-1 BU	Pared lateral detrás 569 CLA-1 BU
5	Panel side 472 CLA-1 BU everp	Face latérale arriere 472 CLA-1 BU	Parete laterale posteriore 472 CLA-1 BU	Zijwand Achter 472 CLA-1 BU	Pared lateral detrás 472 CLA-1 BU
6	Panel side 657 CLA-1 BU everp	Face latérale arriere 657 CLA-1 BU	Parete laterale posteriore 657 CLA-1 BU	Zijwand Achter 657 CLA-1 BU	Pared lateral detrás 657 CLA-1 BU
7	Panel front below CLA-1 everp	Panneau avant bas	Parete anteriore sotto	Voorwand Onder	Pared delantero debajo
8	Back panel CLA-1 75-100 (r) everp	Panneau arriere 75-100 (r)	Parete posteriore 75-100 (r)	Achterwand 75-100 (r)	Pared trasera 75-100 (r)
8	Back panel CLA-1 150 (r) everp	Panneau arriere 150 (r)	Parete posteriore 150 (r)	Achterwand 150 (r)	Pared trasera 150 (r)
8	Back panel CLA-1 200-300 (r) everp	Panneau arriere 200-300 (r)	Parete posteriore 200-300 (r)	Achterwand 200-300 (r)	Pared trasera 200-300 (r)
8	Back panel CLA-1 75-100 (l) everp	Panneau arriere 75-100 (l)	Parete posteriore 75-100 (l)	Achterwand 75-100 (l)	Pared trasera 75-100 (l)
8	Back panel CLA-1 150 (l) everp	Panneau arriere 150 (l)	Parete posteriore 150 (l)	Achterwand 150 (l)	Pared trasera 150 (l)

Übersetzungsliste List of translations		Liste des traductions Traduzione delle descrizioni		Vertalinglijst Lista de traducciones	
Pos	Description	Denomination	Descrizione	Benaming	Descripción
8	Back panel CLA-1 200-300 (l) everp	Panneau arri#re 200-300 (l)	Parete posteriore 200-300 (l)	Achterwand 200-300 (l)	Pared trasera 200-300 (l)
9	Bracket top left CLA-1 200-300 everp	Traverse haut (l) 200-300	Traversa sopra (l) 200-300	Traverse Boven (l) 200-300	Mástil de refuerzo arriba (l) 200-300
9	Bracket top left CLA-1 150 everp	Traverse haut (l) 150	Traversa sopra (l) 150	Traverse Boven (l) 150	Mástil de refuerzo arriba (l) 150
9	Bracket top left CLA-1 75-100 everp	Traverse haut (l) 75-100	Traversa sopra (l) 75-100	Traverse Boven (l) 75-100	Mástil de refuerzo arriba (l) 75-100
10	Plate hood rear CLA-1 everp	Couvercle arri#re	Copertura di protezione posteriore	Afdekking achter	Recubrimiento detrás
11	Pan-head screw ST3,9x9,5 A3T (10x)	Vis # t#te plate ST3,9 (10x)	Vite a testa piana ST3,9x9,5 (10x)	Schroef met vlakke kop ST3,9x9,5 (10x)	Tornillo avellanado ST3,9x9,5 (10x)
12	Screw tapping (10x)	VIS GB402 (10x)	Vite (10x)	Schroef (10x)	Tornillo (10x)
13	Cable clip (5x)	ATTACHE RAPIDE (5x)	Angolare (5x)	Kabelhouder (5x)	Sujetacable (5x)
14	Badge Buderus 186mm	Logo Buderus 186mm	Logo Buderus 186mm	Logo Buderus 186mm	Logotipo Buderus 186mm
15	Bracket top right CLA-1 200-300 everp	Traverse haut (r) 200-300	Traversa sopra (r) 200-300	Traverse Boven (r) 200-300	Mástil de refuerzo arriba (r) 200-300
15	Bracket top right CLA-1 150 everp	Traverse haut (r) 150	Traversa sopra (r) 150	Traverse Boven (r) 150	Mástil de refuerzo arriba (r) 150
15	Bracket top right CLA-1 75-100 everp	Traverse haut (r) 150	Traversa sopra (r) 150	Traverse Boven (r) 150	Mástil de refuerzo arriba (r) 150
16	Switch pressure DL10KH-5WZ everp	contact # pression DL10KH-5WZ	Pressostato DL10KH-5WZ	drukverschilskelaar DL10KH-5WZ	presostato DL10KH-5WZ
16	Switch pressure DL10KH-5WZ 9,5 sp	Contact # pression DL10KH-5WZ 9,5	Pressostato DL10KH-5WZ 9,5	Drukverschilskelaar DL10KH-5WZ 9,5	Presostato DL10KH-5WZ 9,5
17	Pipe gas VM322 VM CLA-1 150-300 everp	Raccordement gaz arri#re 150-300	Raccordo gas posteriore 150-300	Gasaansluiting achter 150-300	Conexión de gas detrás 150-300
17	Pipe gas VM CLA-1 75/100 everp	Raccordement gaz arri#re 75/100	Raccordo gas posteriore 75/100	Gasaansluiting achter 75/100	Conexión de gas detrás 75/100
18	Sheet trafo CLA-1 everp	Plaque de jonction trafo	Lamierino trafo	Houderplaat trafo	Placa de unión trafo
19	Panel top CLA-1 150 (l) everp	Tôle haut 150 (l)	Lamierino sopra 150 (l)	Plaat Boven 150 (l)	Chapa arriba 150 (l)
19	Panel top CLA-1 150 everp	Tôle haut 150 (r)	Lamierino sopra 150 (r)	Plaat Boven 150 (r)	Chapa arriba 150 (r)
19	Panel top CLA-1 200-300 (l) everp	Tôle haut 200-300 (l)	Lamierino sopra 200-300 (l)	Plaat Boven 200-300 (l)	Chapa arriba 200-300 (l)
19	Panel top CLA-1 200-300 everp	Tôle haut 200-300 (r)	Lamierino sopra 200-300 (r)	Plaat Boven 200-300 (r)	Chapa arriba 200-300 (r)
20	collector drain flue gas DN250/ DN200	Collecteur de fumées Cascade DN250/DN200	Collettore gas di scarico DN250 / 200	Rookgasverzamelaar Cascade DN250/DN200	Colector de gases de escape DN250 / 200
20	Collector drain flue gas DN200/ DN160	Collecteur de fumées DN200/ DN160	Collettore combusti DN200/160	RGA-collector DN200/DN160	Colector de gases de escape DN200/160
20	collector drain flue gas DN160/ DN110	Collecteur de fumées DN160/ DN110	Collettore combusti DN160/110	RGA-collector DN160/DN110	Colector de gases de escape DN160/110
21	Installation_kit panel front	Kit de montage frontal	Set di montaggio piastra	Montageset plaat	Juego de montaje placa
3	Element of construction	Groupe de construction	Gruppo di costruzione	Montagegroep	Grupo de construccion
1	Insulation return CLA-1 250 everp	Isolation retour 250	Coibentazione ritorno 250	Isolatie retourleiding 250	Aislamiento tetorno 250
1	Insulation return 150/300 everp	Isolation retour 150/300	Coibentazione ritorno 150/300	Isolatie retourleiding 150/300	Aislamiento tetorno 150/300
1	Insulation return CLA-1 200 everp	Isolation retour 200	Coibentazione ritorno 200	Isolatie retourleiding 200	Aislamiento tetorno 200
2	Insulation front CLA -1 75-500	Isolation avant 75-500	Coibentazione anteriore 75-500	Isolatie voor 75-500	Aislamiento delante 75-500
3	Insulation back CLA -1 75-500	Isolation arri#re 75-500	Coibentazione posteriore 75-500	Isolatie achter 75-500	Aislamiento detrás 75-500
4	Insulation boiler bl. CLA-1 75/100 everp	Isolation bloc chaudi#re 75/100	Coibentazione corpo caldaia 75/100	Isolatie ketelblok 75/100	Aislamiento cuerpo de caldera 75/100

Übersetzungsliste List of translations		Liste des traductions Traduzione delle descrizioni		Vertalinglijst Lista de traducciones	
Pos	Description	Denomination	Descrizione	Benaming	Descripción
4	Insulation boiler block CLA-1 150 everp	ISolation bloc chaudi#re 150	Coibentazione corpo caldaia 150	Isolatie ketelblok 150	Aislamiento cuerpo de caldera 150
4	Insulation boiler block CLA-1 200 everp	ISolation bloc chaudi#re 200	Coibentazione corpo caldaia 200	Isolatie ketelblok 200	Aislamiento cuerpo de caldera 200
4	Insulation boiler block CLA-1 250 everp	ISolation bloc chaudi#re 250	Coibentazione corpo caldaia 250	Isolatie ketelblok 250	Aislamiento cuerpo de caldera 250
4	Insulation boiler block CLA-1 300 everp	ISolation bloc chaudi#re 300	Coibentazione corpo caldaia 300	Isolatie ketelblok 300	Aislamiento cuerpo de caldera 300
5	Insulation Serv. Cov. CLA-1 75/100 everp	Isolation trappe de visite 75/100	Coibentazione coperchio di pul 75/100	Isllatie reinigingsdeksel 75/100	Aislamiento tapa de limpieza 75/100
5	Insulation Service cover CLA-1 150 everp	Isolation trappe de visite 150	Coibentazione coperchio di pul 150	Isllatie reinigingsdeksel 150	Aislamiento tapa de limpieza 150
5	Insulation Service cover CLA-1 200 everp	Isolation trappe de visite 200	Coibentazione coperchio di pul 200	Isllatie reinigingsdeksel 200	Aislamiento tapa de limpieza 200
5	Insulation Service cover CLA-1 250 everp	Isolation trappe de visite 250	Coibentazione coperchio di pul 250	Isllatie reinigingsdeksel 250	Aislamiento tapa de limpieza 250
5	Insulation Service cover CLA-1 300 everp	Isolation trappe de visite 300	Coibentazione coperchio di pul 300	Isllatie reinigingsdeksel 300	Aislamiento tapa de limpieza 300
6	Insulation flow CLA-1 250 everp	Isolation départ 250	Coibentazione mandata 250	Isllatie aanvoer 250	Aislamiento alimentación 250
6	Insulation flow CLA-1 150/300 everp	Isolation départ 150/300	Coibentazione mandata 150/300	Isllatie aanvoer 150/300	Aislamiento alimentación 150/300
6	Insulation flow CLA-1 200 everp	Isolation départ 200	Coibentazione mandata 200	Isllatie aanvoer 200	Aislamiento alimentación 200
7	Tensi springs	RESSORT DE TENSION GB402	Molla di tensione	Spanveer	Muelle tensor
8	Insulation Clamp (10x)	Ressorts de retenue d 0.8 (10x)	Molla di tenuta (10x)	Borgveer (10x)	Muelle tensor para aislamientos (10x)
4	Element of construction	Groupe de construction	Gruppo di costruzione	Montagegroep	Grupo de construccion
1	Extension G1x120 V2	Rallonge G1x120 V2	Prolunga	Verlenging	Prolongacion G1x120 V2
1	Extension G1#x120 V2	rallonge G1#x120 V2 côté	prolunga G1#x120 V2 laterale	verlenging G1#x120 V2 zijkant	prolongacion G1#x120 V2 lateral
3	Safety Group 4-6 Bar 1 1/4"(150 - 300kW)	Set de sécurité 1 1/4" 4-6bar	Set sicurezza 150-300 kW 1"1/4 4-6 bar	Veiligheidsset 1 1/4" 4-6 BAR	Kit Seguridad Caldera 1 1/4" 4-6bar
4	Pressure gauge 100mm D1/2" 0-10bar	Manometre d:100 mm, 0-10bar 1/2"	Manometro davanti d:100mm, 0-10bar 1/2"	Manometer vooraan d:100mm, 0-10bar 1/2"	Manómetro delante d:100mm, 0-10bar 1/2"
5	Air_vent automatic purging system 3/8"	Pot de ventilateur 3/8"	Valvola di sfiato 3/8"	Ontluchtingsdeksel 3/8"	Separador de aire 3/8"
6	Gasket PN16 DN32 43x82x2	JOINT PLAT PN16 DN32 43x82x2 GB402	Guarnizione ad anello piano	Vlakke afdichting	Junta plana PN16 DN32 43x82x2
7	PRESSURE RELEASE VALVE 32/50 6.0 BAR	ARI-SAFE-12903, DN32/50, PN16, EN-JL1040 6b	ARI-SAFE-12903, DN32/50, PN16, EN-JL1040 6b	Ari-Safe-12903, Dn32/50, Pn16, EN-JI1040 6b	Válvula seguridad 6 bar (GB402)
8	PRESSURE RELEASE VALVE 32/50 4 BAR	Ari-safe-12903, DN32/50, pn16, en-jl1040 4b	ARI-SAFE-12903, DN32/50, PN16, EN-JL1040 4b	Ari-Safe-12903, Dn32/50, Pn16, EN-JI1040 4b	Válvula seguridad 4 bar (GB402)
9	PRESSURE RELEASE VALVE 32/50 5 BAR	ARI-SAFE-12903, DN32/50, PN16, EN-JL1040 5b	ARI-SAFE-12903, DN32/50, PN16, EN-JL1040 5b	Ari-Safe-12903, Dn32/50, Pn16, EN-JI1040 5b	Válvula seguridad 5 bar (GB402)
10	Distributor R1	Collecteur R1	Distributore	Kortsluitleiding	Distribuidor R1
10	Distributor R11/4 160-280 everp	CollecteurR11/4 160-280	Distributore	Kortsluitleiding	Distribuidor R11/4 160-280kW
11	Distributor R11/4 160-280 everp	CollecteurR11/4 160-280	Distributore	Kortsluitleiding	Distribuidor R11/4 160-280kW
11	Safety valve	Soupape de sécurité 1 1/4	Valvola di sicurezza	Veiligheidsklep	Logafix Válvula de Seguridad 1 1/4" 3bar
12	Safety valve	Soupape de sécurité 1 1/4	Valvola di sicurezza	Veiligheidsklep	Logafix Válvula de Seguridad 1 1/4" 3bar
16	Pressure gauge for closed conn.,	Manometre pr install fermees 2.5 bar	Manometro 2,5bar 63mm AE D3/8"U	Manometer 2,5bar 63mm AE D3/8"U	Manómetro 2,5bar 63mm AE D3/8"U
5A	Element of construction	Groupe de construction	Gruppo di costruzione	Montagegroep	Grupo de construccion

Übersetzungsliste List of translations		Liste des traductions Traduzione delle descrizioni		Vertalinglijst Lista de traducciones	
Pos	Description	Denomination	Descrizione	Benaming	Descripción
1	Burner unit 75 & 100 kW packed	unité de br#leur 75 & 100 kW	gruppo bruciatore 75 & 100 kW	brander eenheid 75 & 100 kW	quemador 75 & 100 kW
2	Burner unit 150 kW packed	unité de br#leur 150 kW	gruppo bruciatore 150 kW	brander eenheid 150 kW	quemador 150 kW
3	Burner unit 200 kW packed	unité de br#leur 200 kW	gruppo bruciatore 200 kW	brander eenheid 200 kW	quemador 200 kW
3	Burner unit 250 kW packed	unité de br#leur 250 kW	gruppo bruciatore 250 kW	brander eenheid 250 kW	quemador 250 kW
3	Burner unit 300 kW packed	unité de br#leur 300 kW	gruppo bruciatore 300 kW	brander eenheid 300 kW	quemador 300 kW
4	Service set KB372 / Condens 7000F packed	Set de service KB372 / Condens 7000F emb	Imballato KB372 / Condens 7000F di servi	Service set KB372 / Condens 7000F verpak	Conjunto de servicio KB372 / Condens 700
5B	Element of construction	Groupe de construction	Gruppo di costruzione	Montagegroep	Grupo de construccion
1	Burner tube d114,8-L367,4 (200kW) packed	rampe de combustion d114,8-L367,4(200kW)	torcia del bruciatore d114,8-L367,4	staafrander d114,8-L367,4 (200kW)	barra combustible d114,8-L367,4 (200kW)
1	Burner tube d114,8-L185,4 (100kW) packed	rampe de combustion d114,8 - L185,4(100kW)	torcia del bruciatore d114,8 - L185,4	staafrander d114,8 - L185,4 (100kW)	barra combustible d114,8 - L185,4(100kW)
1	Burner tube d114,8-L276,4 (150kW) packed	rampe de combustion d114,8 - L276,4(150kW)	torcia del bruciatore d114,8 - L276,4	staafrander d114,8 - L276,4 (150kW)	barra combustible d114,8 - L276,4(150kW)
1	Burner tube d114,8-L465,4 (250kW) packed	rampe de combustion d114,8-L465,4 (250kW)	torcia del bruciatore d114,8-L465,4	staafrander d114,8 - L465,4 (250kW)	barra combustible d114,8 - L465,4(250kW)
1	Burner tube d114,8-L556,4 (300kW) packed	rampe de combustion d114,8-L556,4(300kW)	torcia del bruciatore d114,8 - L556,4	staafrander d114,8 - L556,4 (300kW)	barra combustible d114,8 - L556,4(300kW)
2	Gasket burner rod VM G-Unit packed	Joint rampe de combustion VM G-Unit	Guarnizione torcia del bruciatore VM G-U	Pakking staafrander VM G-Unit	Junta barra combustible VM G-Unit
3	Nut M4 (10x) packed	Ecrou M4 (10x)	Dado M4 (10x)	Moer M4 (10x)	Tuerca hexagonal M4 (10x)
4	Glass_sight M16x1 kpl	verre du viseur M16x1	vetrino M16x1	kijkglas M16x1	mirilla M16x1
5	Switch bimetal 130°C packed	Interrupteur 130°C	Interruttore 130°C	Schakelaar 130°C	Limitador 130°C"
6	Pressure tapping G1/8"	Prise de pression G1/8"	Presa pressione G1/8"	Meetnippel gasklep G1/8"	Toma presiones 1/8
7	Bolt threaded M4x22 (10x) packed	tige filetée M4 x 22 (10x)	Perno filettato M4 x 22 (10x)	draadstift M4 x 22 (10x)	tornillo de sujeción M4 x 22 (10x)
8	Electrode ionisation VM G-Unit packed	électrode de contrôle VM G-Unit	elettrodo di controllo VM G-Unit	ionisatie-elektrode VM G-Unit	electrodo de control VM G-Unit
9	Ignition electrode VMU G-Unit packed	électrode d'allumage VM G-Unit	elettrodo di accensione VM G-Unit	ontstekingselektrode VM G-Unit	electrodo de encendido VM G-Unit
10	Seal electrode (2x)	Joint électrode (2x)	Guarnizione Elettrodo (2x)	Pakking elektrode (2x)	Junta electrodo (2x)
11	Burner hood VM G-Unit 75-150 kW packed	Coude VM G-Unit 75-150 kW	Curva VM G-Unit 75-150 kW	Bocht VM G-Unit 75-150 kW	Arco VM G-Unit 75-150 kW
11	Burner hood VM G-Unit 200-300 kW packed	Coude VM G-Unit 200-300 kW	Curva VM G-Unit 200-300 kW	Bocht VM G-Unit 200-300 kW	arco VM G-Unit 200-300 kW
12	Rod M6x 50 (6x) packed	boulon fileté M6 x 50 (6x)	bullone M6 x 50 (6x)	bout M6 x 50 (6x)	perno roscado M6 x 50 (6x)
13	Nut M6 EN 1661 - 8.8 A3K packed (10x)	écrou M6 EN 1661 - 8.8A3K (10x)	dado M6 EN 1661 - 8.8A3K (10x)	moer M6 EN 1661 - 8.8A3K (10x)	tuerca M6 EN 1661 - 8.8A3K (10x)
14	Gasket flange 134,08x109,08x5,33 packed	joint torique 134,08x109,08x5,33 mm (3x)	o-ring 134,08x109,08x5,33 mm (3x)	O-ring 134,08x109,08x5,33 mm (3x)	anillo tórico 134,08x109,08x5,33 mm (3x)
15	Nut M8 EN 1661 (10x) packed	écrou M8 EN 1661 (10x)	dado M8 EN 1661 (10x)	moer M8 EN 1661 (10x)	tuerca M8 EN 1661 (10x)
17	Gasket flange 67,4x67,4x3,0 (3x) packed	joint profilé 67,4x 67,4x 3 mm (3x)	Guarnizione profilata 67,4x 67,4x 3 mm (3x)	vormafdichting 67,4x 67,4x 3 mm (3x)	junta moldeada 67,4x 67,4x 3 mm (3x)
18	Nut - M5 - A2-70 knurled (10 pc) packed	écrou M5-A2-70 sperrv(10 St)	dado M5-A2-70 sperrv(10 St)	moer M5-A2-70 sperrv(10 St)	tuerca M5-A2-70 sperrv(10 St)
19	Bolt threaded M5 x 25 mm (10x) packed	tige filetée M5 x 25 mm (10x)	Perno filettato M5 x 25 mm (10x)	draadstift M5 x 25 mm (10x)	tornillo de sujeción M5 x 25 mm (10x)
20	Seal O-ring 177,17x5,33 sp	JOINT TORIQUE NITRILE DIA.17x5,33	Anello di tenuta 17x5,33	O-Ring 17x5,33	Anillo tórico 17x5,33
6A	Element of construction	Groupe de construction	Gruppo di costruzione	Montagegroep	Grupo de construccion

Übersetzungsliste List of translations		Liste des traductions Traduzione delle descrizioni		Vertalinglijst Lista de traducciones	
Pos	Description	Denomination	Descrizione	Benaming	Descripción
1	Gas valve VR4615 (100 kW) packed	bloc gaz VR 4615 (100 kW)	valvola del gas VR 4615 (100 kW)	gasregelblok VR 4615 (100 kW)	válvula del gas VR 4615 (100 kW)
1	Gas valve VR 4615 (75 kW) packed	bloc gaz VR 4615 (75 kW)	valvola del gas VR 4615 (75 kW)	gasregelblok VR 4615 (75 kW)	válvula del gas VR 4615 (75 kW)
2	Gas valve VR415 packed	bloc gaz VR 415	valvola del gas VR 415	gasregelblok VR 415	válvula del gas VR 415
3	Sealing 33x24x3.5 (10x)	Joint 33x24x3,5 (10x)	Guarnizione 33x24x3,5 (10x)	Pakking 33x24x3,5 (10x)	Sealing 33x24x3.5 (10x)
4	O-ring 52,39x3,53	Joint torique 52,39x3,53	Anello tenuta 52,39x3,53	O-ring 52,39x3,53	Anillo tórico 52,39x3,53
5	Screw in socket GES4/R1/8 straight (3x)	raccord NW4XR1/8 droit (3x)	Raccordo filettato NW4XR1/8 in linea(3x)	draadstuk NW4XR1/8 recht (3x)	racor de conexión macho NW4XR1/8 (3x)
6	cheese- head screw DIN 912 M5x16 (8x)	Fillister(cheese)-head DIN 912 M5x16(8x)	cheese- head screw DIN 912 M5x16 (8x)	Cilinderschroef DIN 912 M5x16(8x)	Tornillo DIN 912 M5x16 (8x)
7	Adaptor connection out VR4615 G1 packed	bride VR4615	Flangia VR4615	flens VR4615	brida VR4615
8	Flange VR4XX 1" packed	bride VR4XX 1"	Flangia VR4XX 1"	flens VR4XX 1"	brida VR4XX 1
9	Tube gas flex DN20 CLA-1 packed	tuyau flexible DN20 CLA-1	tubo flessibile DN20 CLA-1	flex pijp DN20 CLA-1	tubo de flexión DN20 CLA-1
10	Seal D24x30,5x2 AFM34 (1x) packed	Joint D24x30,5x2 AFM34 (1x)	Guarnizione D24x30,5x2 AFM34 (1x)	Pakking D24x30,5x2 AFM34 (1x)	Junta D24x30,5x2 AFM34 (1x)
11	Fan EBM NRG-137 75-100KW packed	ventilateur EBM NRG-137 - 75-100 kW	ventilatore EBM NRG-137 - 75-100 kW	ventilator EBM NRG-137 - 75-100 kW	ventilador EBM NRG-137 - 75-100 kW
12	Fan EBM NRG-137 150KW packed	ventilateur EBM NRG-137 - 150 kW	ventilatore EBM NRG-137 - 150 kW	ventilator EBM NRG-137 - 150 kW	ventilador EBM NRG-137 - 150 kW
15	Connector VM G-Unit 75-300 kW packed	connecteur VM G-Unit 75-300	spina VM G-Unit 75-300	connector VM G-Unit 75-300	enchufe VM G-Unit 75-300
16	O-Ring 6,07 x 1,78 (5x) packed	joint torique 6,07 x 1,78 (5x)	o-ring 6,07 x 1,78 (5x)	O-ring 6,07 x 1,78 (5x)	anillo tórico 6,07 x 1,78 (5x)
17	Hose compensation packed	LIGNE DE COMPENSATION	Risarcimento	Compensatie	Tubo venturi
18	Hose protection (Clamp) (10) packed	fusible de tube (10x)	fusibile tubo (10x)	buis zekering (10x)	fusible de tubo (10x)
19	Throttle gas VR4615 D=8,70 mm packed	réglage de gaz VR4615 D=8,70 mm	valvola a farfalla VR4615 D=8,70 mm	gassmoorklep VR4615 D=8,70 mm	estrangulador de gas VR4615 D=8,70 mm
19	Throttle gas VR4615 D=9,90 mm packed	réglage de gaz VR4615 D=9,90 mm	valvola a farfalla VR4615 D=9,90 mm	gassmoorklep VR4615 D=9,90 mm	estrangulador de gas VR4615 D=9,90 mm
20	Throttle gas VR46XX D=9,80 mm packed	réglage de gaz VR46XX D=9,80 mm	valvola a farfalla VR46XX D=9,80 mm	gassmoorklep VR46XX D=9,80 mm	estrangulador de gas VR46XX D=9,80 mm
20	Throttle gas VR4XX D=20,00 mm packed	réglage de gaz VR4XX D=20,00 mm	valvola a farfalla VR4XX D=20,00 mm	gassmoorklep VR4XX D=20,00 mm	estrangulador de gas VR4XX D=20,00 mm
20	Throttle gas VR46XX D=6,80 mm packed	réglage de gaz VR46XX D=6,80 mm	valvola a farfalla VR46XX D=6,80 mm	gassmoorklep VR46XX D=6,80 mm	estrangulador de gas VR46XX D=6,80 mm
20	Throttle gas VR4XX D = 8,50 mm packed	réglage de gaz VR4XX D = 8,50 mm	valvola a farfalla VR4XX D = 8,50 mm	gassmoorklep VR4XX D = 8,50 mm	estrangulador de gas VR4XX D = 8,50 mm
20	Throttle gas VR4XX D = 12,30 mm packed	réglage de gaz VR4XX D = 12,30 mm	valvola a farfalla VR4XX D = 12,30 mm	gassmoorklep VR4XX D = 12,30 mm	estrangulador de gas VR4XX D = 12,30 mm
20	Throttle gas VR4XX D = 21,00 mm packed	réglage de gaz VR4XX D = 21,00 mm	valvola a farfalla VR4XX D = 21,00 mm	gassmoorklep VR4XX D = 21,00 mm	estrangulador de gas VR4XX D = 21,00 mm
6B	Element of construction	Groupe de construction	Gruppo di costruzione	Montagegroep	Grupo de construccion
1	Gas valve VR420 (200 kW) packed	bloc gaz VR 420 (200 kW)	valvola del gas VR 420 (200 kW)	gasregelblok VR 420 (200 kW)	válvula del gas VR 420 (200 kW)
1	Gas valve VR420 (250 kW) packed	bloc gaz VR 420 (250 kW)	valvola del gas VR 420 (250 kW)	gasregelblok VR 420 (250 kW)	Válvula del gas VR 420 (250 kW)
1	Gas valve VR425 packed	bloc gaz VR 425	valvola del gas VR 425	gasregelblok VR 425	válvula del gas VR 425
2	O-ring 52,39x3,53	Joint torique 52,39x3,53	Anello tenuta 52,39x3,53	O-ring 52,39x3,53	Anillo tórico 52,39x3,53
3	Flange VR4XX 1 1/8" packed	bride VR4XX 1 1/8"	Flangia VR4XX 1 1/8"	flens VR4XX 1 1/8"	brida VR4XX 1 1/8
4	Screw in socket GES4/R1/8 straight (3x)	raccord NW4XR1/8 droit (3x)	Raccordo filettato NW4XR1/8 in linea(3x)	draadstuk NW4XR1/8 recht (3x)	racor de conexión macho NW4XR1/8 (3x)

Übersetzungsliste List of translations		Liste des traductions Traduzione delle descrizioni		Vertalinglijst Lista de traducciones	
Pos	Description	Denomination	Descrizione	Benaming	Descripción
5	cheese- head screw DIN 912 M5x16 (8x)	Fillister(cheese)-head DIN 912 M5x16(8x)	cheese- head screw DIN 912 M5x16 (8x)	Cilinderschroef DIN 912 M5x16(8x)	Tornillo DIN 912 M5x16 (8x)
6	Tube gas flex DN25 CLA-1 packed	tuyau flexible DN25 CLA-1	tubo flessibile DN25 CLA-1	flex pijp DN25 CLA-1	tubo de flexión DN25 CLA-1
7	seal set D27x38x2mm (Set 5 Pice)	JOINT D27x38x2MM (X5)	Set guarnizioni D27x38x2mm (set 5 pz.)	Afdichtingsset D27x38x2mm (set 5 st)	Juego de juntas D27x38x2mm (5x)
8	Fan EBM G1G170 packed	ventilateur EBM G1G170	ventilatore EBM G1G170	ventilator EBM G1G170	ventilador EBM G1G170
9	Venturi VMU 185 packed	Venturi VMU 185	Venturi VMU 185	Venturi VMU 185	Venturi VMU 185
9	Venturi VMU 300 packed	Venturi VMU 300	Venturi VMU 300	Venturi VMU 300	Venturi VMU 300
10	Seal Venturi	Joint Venturi	Guarnizione Venturi	Dichting voor ventilator GB312	Junta Venturi valvula de gas GB312
11	Nut M8 EN 1661 (10x) packed	écrou M8 EN 1661 (10x)	dado M8 EN 1661 (10x)	moer M8 EN 1661 (10x)	tuerca M8 EN 1661 (10x)
12	Air throttle D20	CLAPET D'AIR D20	Valvola a farfalla D20	Gasinspuitter D20	Estrangulación de aire D20
12	Air throttle D27 packed	CLAPET D'AIR D27	Valvola a farfalla D27	Gasinspuitter D27	Estrangulación de aire D27
13	Screw - Hexagon-head M8x12 (8Pc) mverp	Vis # #t#te hexagonale M8x12 (8x)	Vite M8x12 (8x)	Schroef M8x12 (8x)	Tornillo M8x12 (8x)
14	Flange G1 1/8" packed	bride G 1 1/8"	Flangia G 1 1/8"	flens G 1 1/8"	brida G 1 1/8
15	Connector VM G-Unit 75-300 kW packed	connecteur VM G-Unit 75-300	spina VM G-Unit 75-300	connector VM G-Unit 75-300	enchufe VM G-Unit 75-300
16	O-Ring 6,07 x 1,78 (5x) packed	joint torique 6,07 x 1,78 (5x)	o-ring 6,07 x 1,78 (5x)	O-ring 6,07 x 1,78 (5x)	anillo tórico 6,07 x 1,78 (5x)
17	Hose compensation packed	LIGNE DE COMPENSATION	Risarcimento	Compensatie	Tubo venturi
18	Hose protection (Clamp) (10) packed	fusible de tube (10x)	fusibile tubo (10x)	buis zekering (10x)	fusible de tubo (10x)
19	Throttle gas VR4XX D=18,00 mm packed	réglage de gaz VR4XX D=18,00 mm	valvola a farfalla VR4XX D=18,00 mm	gassmoorklep VR4XX D=18,00 mm	Estrangulador de gas VR4XX D=18,00 mm
19	Throttle gas VR4XX D=25,40 mm packed	réglage de gaz VR4XX D=25,40 mm	valvola a farfalla VR4XX D=25,40 mm	gassmoorklep VR4XX D=25,40 mm	Estrangulador de gas VR4XX D=25,40 mm
19	Throttle gas VR4XX D=25,20 mm packed	réglage de gaz VR4XX D=25,20 mm	valvola a farfalla VR4XX D=25,20 mm	gassmoorklep VR4XX D=25,20 mm	Estrangulador de gas VR4XX D=25,20 mm
19	Throttle gas VR4XX D = 10,30 mm packed	réglage de gaz VR4XX D = 10,30 mm	valvola a farfalla VR4XX D = 10,30 mm	gassmoorklep VR4XX D = 10,30 mm	Estrangulador de gas VR4XX D = 10,60 mm
19	Throttle gas VR4XX D = 11,30 mm packed	réglage de gaz VR4XX D = 11,30 mm	valvola a farfalla VR4XX D = 11,30 mm	gassmoorklep VR4XX D = 11,30 mm	Estrangulador de gas VR4XX D = 11,30 mm
19	Throttle gas VR4XX D = 12,10 mm packed	réglage de gaz VR4XX D = 12,10 mm	valvola a farfalla VR4XX D = 12,10 mm	gassmoorklep VR4XX D = 12,10 mm	Estrangulador de gas VR4XX D = 12,10 mm
19	Throttle gas VR4XX D = 14,40 mm packed	réglage de gaz VR4XX D = 14,40 mm	valvola a farfalla VR4XX D = 14,40 mm	gassmoorklep VR4XX D = 14,40 mm	estrangulador de gas VR4XX D = 14,40 mm
19	Throttle gas VR4XX D = 19,00 mm packed	réglage de gaz VR4XX D = 19,00 mm	valvola a farfalla VR4XX D = 19,00 mm	gassmoorklep VR4XX D = 19,00 mm	estrangulador de gas VR4XX D = 19,00 mm
19	Throttle gas VR4XX D = 16,30 mm packed	réglage de gaz VR4XX D = 16,30 mm	valvola a farfalla VR4XX D = 16,30 mm	gassmoorklep VR4XX D = 16,30 mm	estrangulador de gas VR4XX D = 16,30 mm
19	Throttle gas VR4XX D = 25,60 mm packed	réglage de gaz VR4XX D = 25,60 mm	valvola a farfalla VR4XX D = 25,60 mm	gassmoorklep VR4XX D = 25,60 mm	estrangulador de gas VR4XX D = 25,60 mm
19	Throttle gas VR4XX D = 17,30 mm packed	réglage de gaz VR4XX D = 17,30 mm	valvola a farfalla VR4XX D = 17,30 mm	gassmoorklep VR4XX D = 17,30 mm	estrangulador de gas VR4XX D = 17,30 mm
19	Throttle gas VR4XX D = 26,00 mm packed	réglage de gaz VR4XX D = 26,00 mm	valvola a farfalla VR4XX D = 26,00 mm	gassmoorklep VR4XX D = 26,00 mm	estrangulador de gas VR4XX D = 26,00 mm
20	O-Ring 110,0 x 3,2 mm packed (3x)	joint torique 110,0 x 3,2 mm (3x)	o-ring 110,0 x 3,2 mm (3x)	O-ring 110,0 x 3,2 mm (3x)	anillo tórico 110,0 x 3,2 mm (3x)
21	Seal adaptor VMU (3x) packed	joint VMU (3x)	guarnizione VMU (3x)	pakking VMU (3x)	junta VMU (3x)
22	Gasket flange 134,08x109,08x5,33 packed	joint torique 134,08x109,08x5,33 mm (3x)	o-ring 134,08x109,08x5,33 mm (3x)	O-ring 134,08x109,08x5,33 mm (3x)	anillo tórico 134,08x109,08x5,33 mm (3x)
23	Nut liike EN1663 - M5 -8 blk (10x) pack	écrou EN1663 -M5 -8 sw(10x)	dado EN1663 -M5 -8 sw(10x)	moer EN1663 -M5 -8 sw(10x)	tuerca EN1663 -M5 -8 sw(1x)

Übersetzungsliste List of translations		Liste des traductions Traduzione delle descrizioni		Vertalinglijst Lista de traducciones	
Pos	Description	Denomination	Descrizione	Benaming	Descripción
7	Element of construction	Groupe de construction	Gruppo di costruzione	Montagegroep	Grupo de construcción
1	Adaptor RLU DN110 packed	adaptateur RLU DN110	adattore RLU DN110	adapter RLU DN110	adaptador RLU DN110
2	Adaptor RLU DN160 packed	adaptateur RLU DN160	adattore RLU DN160	adapter RLU DN160	adaptador RLU DN160
3	Clamp DN 140 packed	Support d=140mm	Staffa d=140mm	Klembeugel d=140mm	abrazadera d=140mm
4	Seal adaptor RLU Di=122 (3x) packed	joint RLU Di=122 (3x)	guarnizione RLU Di=122 (3x)	pakking RLU Di=122 (3x)	junta RLU Di=122 (3x)
5	Flap supply VM G-Unit packed	clapet d'air VM G-Unit	valvola dell'aria VM G-Unit	luchtklep VM G-Unit	tapa de aire VM G-Unit
6	Plug holding air flap (10x) packed	bouchon (10x)	tappo (10x)	stop (10x)	tapon (10x)
7	Adaptor suction NRG packed	Raccord NRG	Adattore NRG	Adapter NRG	Adaptador NRG
8	Adaptor suction VMU 200 kW packed	Adaptateur d'aspiration VMU 200 kW embal	Imballaggio adattatore VMU 200 kW	Adapterzuiger VMU 200 kW verpakt	Adaptador de succión VMU 200 kW embalado
8	Adaptor suction VMU packed	Raccord VMU	Adattore VMU	Adapter VMU	Adaptador VMU
9	Screw hex M6x12 ISO4017 (10x) packed	Vis # t#te hexagonale M6x12 ISO4017 (10x)	Vite M6x12 ISO4017 (10x)	Schroef M6x12 ISO4017 (10x)	Tornillo M6x12 ISO4017 (10x)
10	Seal adaptor NRG (3x) packed	joint NRG (3x)	guarnizione NRG (3x)	pakking NRG (3x)	junta NRG (3x)
11	Seal adaptor VMU (3x) packed	joint VMU (3x)	guarnizione VMU (3x)	pakking VMU (3x)	junta VMU (3x)
12	Hose band clip NRG (3x) packed	collier de serrage NRG (3x)	fascetta stringitubo NRG (3x)	slangklem NRG (3x)	abrazadera de manguera NRG (3x)
13	Nut M6 EN 1661 - 8.8 A3K packed (10x)	écrou M6 EN 1661 - 8.8A3K (10x)	dado M6 EN 1661 - 8.8A3K (10x)	moer M6 EN 1661 - 8.8A3K (10x)	tuerca M6 EN 1661 - 8.8A3K (10x)
14	Cover air filter box packed	couvercle air ambiant	coperchio camera aria	luchtdicht kastdeksel	tapa de la cámara de aire
15	Panel front air box packed	panneau avant caisson	parete anteriore camera aria	voorwand luchtomspoelde ruimte	pared delantero cámara de aire
16	Air filter D220x404 mm packed	Filtre # air D220x404 mm	Filtro dell'aria D220x404 mm	luchtfilters D220x404 mm	Filtro de aire D220x404 mm
17	Hose DN160 air 450 mm packed	tuyau DN160-450 mm	tubo flessibile DN160-450 mm	slang DN160-450 mm	manguera DN160-450 mm
18	Fill level indicator packed	indicateur de niveau	Indicatore di livello	niveau-aanduiding	indicación de nivel
8	Element of construction	Groupe de construction	Gruppo di costruzione	Montagegroep	Grupo de construcción
1	SAFE 44 V3 sp	SAFE 44 V3	SAFE 44 V3	SAFE 44 V3	SAFE 44 V3
2	Housing Terminal cover SAFE	Couvercle safe GB402	Coperchio SAFE	Behuizing klemmenstrook SAFE	Carcasa cubre conexiones SAFE
3	Module BIM44 6501-V5 KB372-75 sp	module BIM44 6501-V5 KB372-75	Modulo BIM44 6501-V5 KB372-75	module BIM44 6501-V5 KB372-75	módulo BIM44 6501-V5 KB372-75
3	Module BIM44 6502-V5 KB372-100 sp	module BIM44 6502-V5 KB372-100	Modulo BIM44 6502-V5 KB372-100	module BIM44 6502-V5 KB372-100	módulo BIM44 6502-V5 KB372-100
3	Module BIM44 6503-V5 KB372-150 sp	module BIM44 6503-V5 KB372-150	Modulo BIM44 6503-V5 KB372-150	module BIM44 6503-V5 KB372-150	módulo BIM44 6503-V5 KB372-150
3	Module BIM44 6504-V5 KB372-200 sp	module BIM44 6504-V5 KB372-200	Modulo BIM44 6504-V5 KB372-200	module BIM44 6504-V5 KB372-200	módulo BIM44 6504-V5 KB372-200
3	Module BIM44 6505-V5 KB372-250 sp	module BIM44 6505-V5 KB372-250	Modulo BIM44 6505-V5 KB372-250	module BIM44 6505-V5 KB372-250	módulo BIM44 6505-V5 KB372-250
3	Module BIM44 6506-V5 KB372-300 sp	module BIM44 6506-V5 KB372-300	Modulo BIM44 6506-V5 KB372-300	module BIM44 6506-V5 KB372-300	módulo BIM44 6506-V5 KB372-300
4	Cable Fan PWM WIDW 900/2740 everp	CABLE DE LIAISON VENTIL PWM WIDW900/2740	Tubazione di collegamento PWM WIDW	Verbindingsleiding PWM WIDW 900/2740	Cable de conexión ventilador PWM WIDW
4	Cable Fan WM WIDW 920/3300 everp	CABLE DE LIAISON VENTIL WM WIDW 920/3300	Tubazione di collegamento WM WIDW 920/33	Verbindingsleiding WM WIDW 920/3300	Cable de conexión ventilador WM WIDW 920/
5	Cable Ionisation cpl everp	câbles d'ionisation	Cavo di ionizzazione	ionisatiekabel	conjunto cables de ionización

Übersetzungsliste List of translations		Liste des traductions Traduzione delle descrizioni		Vertalinglijst Lista de traducciones	
Pos	Description	Denomination	Descrizione	Benaming	Descripción
6	Cable pressure switch 3Y 290/2600 everp	câble de connexion contrôleur de pressio	tubazione di collegamento Pressostato 3Y	verbindingsbuis drukwachter 3Y 290/2600	tubo de conexión presostato 3Y 290/2600
6	Cable pressure switch 3Y 290/760 everp	câble de connexion contrôleur de pressio	tubazione di collegamento Pressostato 3Y	verbindingsbuis drukwachter 3Y 290/760	tubo de conexión presostato 3Y 290/760
7	Cable FF/Return Sensor 1450/2600 everp	CABLE DE SONDE DEPART/RETOUR 1450/2600	Tubazione di collegamento 1450/2600	Verbindingsleiding 1450/2600	Conexión impulsión/retorno 1450/2600
7	Cable FF/Return Sensor 2000/3450 everp	CABLE DE SONDE DEPART/RETOUR 2000/3450	Tubazione di collegamento 2000/3450	Verbindingsleiding 2000/3450	Conexión impulsión/retorno 2000/3450
8	Con cable sensor SAFe socket	Conduite de raccordement SAFe	Tubazione di collegamento SAFe	Verbindingsleiding SAFe	Tubo de conexión SAFe
9	Data cable SAFe MC10 BE	Cable bus safe - MC10	Tubazione di collegamento SAFe MC10 BE	Verbindingsleiding Safe MC10 BE	Cable de datos SAFe MC 10 BE
10	Cable MV1 MV2 1300 everp	câble de connexion MV1 MV2 1300	tubazione di collegamento MV1 MV2 1300	verbindingsbuis MV1 MV2 1300	tubo de conexión MV1 MV2 1300
10	Cable MV1 MV2 1100 everp	câble de connexion MV1 MV2 1100	tubazione di collegamento MV1 MV2 1100	verbindingsbuis MV1 MV2 1100	tubo de conexión MV1 MV2 1100
11	Cable Ignition 1200 everp	Conduite de raccordement SAFe-Allumage	Tubazione di collegamento SAFe-Accension	verbindingsleiding SAFe- Ontsteking 1200	tubo de conexión SAFe-De encendido 1200
12	Y- Cable SAFe Fan 980/650 everp	Y-câble SAFe ventilateur 980/650	Y-cavo SAFe ventilatore 980/650	Y-kabel SAFe ventilator 980/650	Y-cables SAFe ventilador 980/650
13	Y- Cable SAFe Fan 1400/1100 everp	Y-câble SAFe ventilateur 1400/1100	Y-cavo SAFe ventilatore 1400/1100	Y-kabel SAFe ventilator 1400/1100	Y-cables SAFe ventilador 1400/1100
14	Switch pressure DL10KH-5WZ everp	contact # pression DL10KH-5WZ	Pressostato DL10KH-5WZ	drukverschilskakelaar DL10KH-5WZ	presostato DL10KH-5WZ
14	Switch pressure DL10KH-5WZ 9,5 sp	Contact # pression DL10KH-5WZ 9,5	Pressostato DL10KH-5WZ 9,5	Drukverschilskakelaar DL10KH-5WZ 9,5	Presostato DL10KH-5WZ 9,5
15	SwitchPressure Typ 605 23/15Pa cpl everp	contact # pression 605 23/15Pa	Pressostato 605 23/15Pa	drukverschilskakelaar 605 23/15Pa	presostato 605 23/15Pa
16	Inductor for NRG137 everp	Diaphragme NRG137	Disco strozzatore NRG137	DIAFRAGMA NRG137	Disco de estrangulación NRG137
17	Ignition Danfoss EBI V4 spare part	Transformateur allumage ebi danfoss v4	Dispositivo di accensione Danfoss EBI V4	Ontstekingsunit Danfoss EBI V4	Transformador de encendido EBI V4
18	Gloeikabel vm312 D7 SD6,3 SD4	CABLE D'ALLUMAGE D7 SD6,3 SD4	Cavetto accensione D7 SD6,3 SD4	Ontstekingskabel D7 SD6,3 SD4	Cable de encendido D7 SD6,3 SD4

Gerätetypen Types of appliances	Types de chaudières Tipo apparecchi	Toesteltypes Tipos de aplicaciones	Bemerkungen Remarks Remarques Osservazioni Opmerkingen Observaciones
Gerät Appliance Chaudière Apparecchio Toestel Aparato	Bestell-Nr. Ordering no. Numéro de commande N° d'ordine Bestelnummer Número el ordenar	Land Country Pays Paese Land Paese	
KB372-100 H (L)	8 732 908 034	Belgien, Deutschland, Estland, Griechenland	
KB372-100 H (R)	8 732 907 691	Belgien, Deutschland, Estland, Griechenland	
KB372-150 H (L)	8 732 908 035	Belgien, Deutschland, Estland, Griechenland	
KB372-150 H (R)	8 732 907 692	Belgien, Deutschland, Estland, Griechenland	
KB372-200 H (L)	8 732 908 036	Belgien, Deutschland, Estland, Griechenland	
KB372-200 H (R)	8 732 907 693	Belgien, Deutschland, Estland, Griechenland	
KB372-250 H (L)	8 732 908 037	Belgien, Deutschland, Estland, Griechenland	
KB372-250 H (R)	8 732 907 694	Belgien, Deutschland, Estland, Griechenland	
KB372-300 H (L)	8 732 908 038	Belgien, Deutschland, Estland, Griechenland	
KB372-300 H (R)	8 732 907 695	Belgien, Deutschland, Estland, Griechenland	
KB372-75 H (l)	8 732 908 033	Belgien, Deutschland, Estland, Griechenland	
KB372-75 H (r)	8 732 907 690	Belgien, Deutschland, Estland, Griechenland	
KB372-100 (L)	7 736 603 283	Türkei	
KB372-100 (R)	7 736 603 277	Türkei	
KB372-150 (L)	7 736 603 284	Türkei	
KB372-150 (R)	7 736 603 278	Türkei	
KB372-200 (L)	7 736 603 285	Türkei	
KB372-200 (R)	7 736 603 279	Türkei	
KB372-250 (L)	7 736 603 286	Türkei	
KB372-250 (R)	7 736 603 280	Türkei	
KB372-300 (L)	7 736 603 287	Türkei	
KB372-300 (R)	7 736 603 281	Türkei	
KB372-75 (l)	7 736 603 282	Türkei	
KB372-75 (r)	7 736 603 276	Türkei	

Bosch Thermotechnik GmbH
Sophienstr. 30-32
D-35576 Wetzlar / Germany

Buderus