

SE625 / SE725

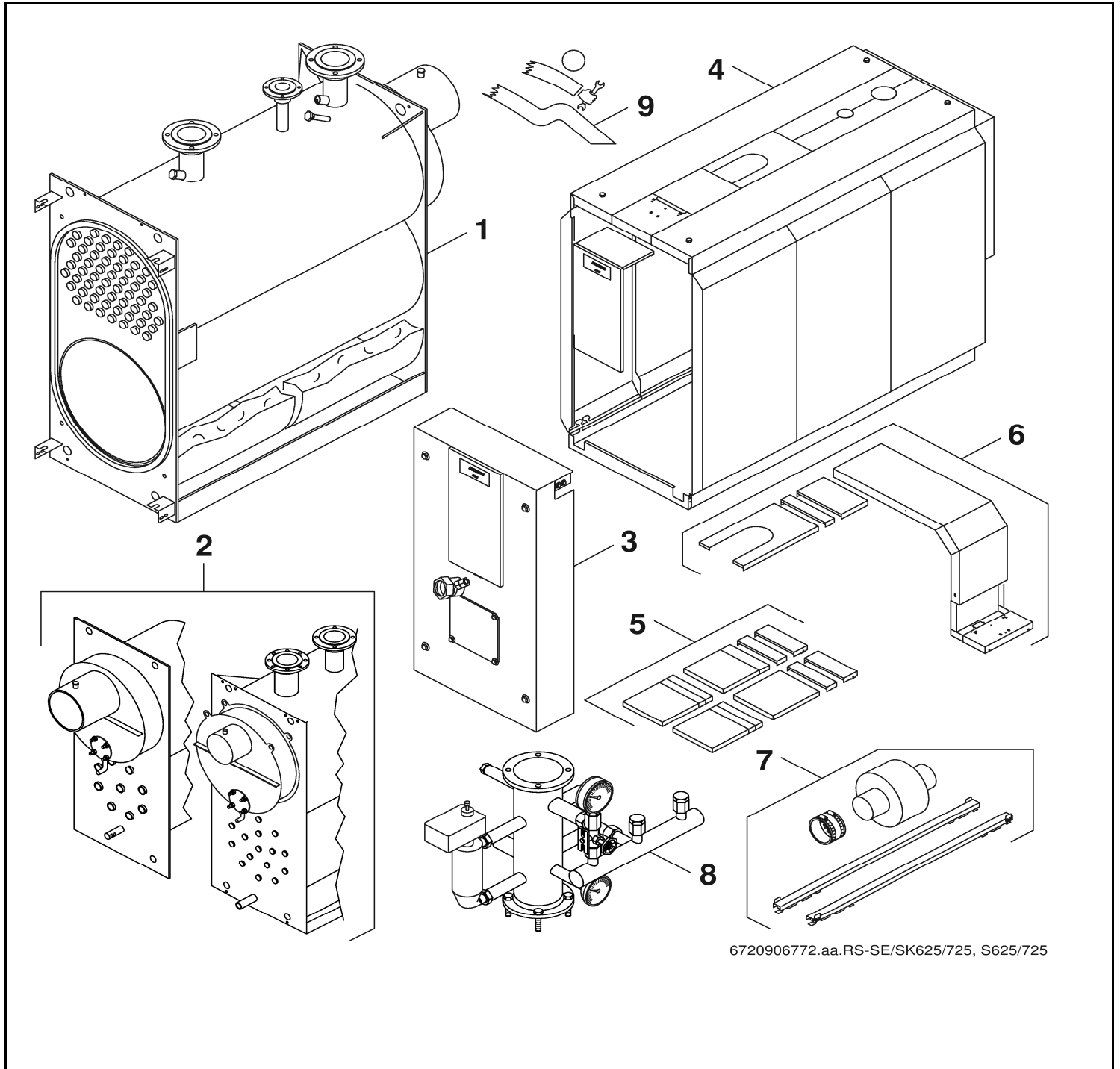

6720906772.aa.RS-SE/SK625/725, S625/725

Buderus

[de] Wichtige Hinweise zur Installation/Montage

Die Installation/Montage muss durch eine für die Arbeiten zugelassene Fachkraft unter Beachtung der geltenden Vorschriften erfolgen.

[en] Important notes on installation/assembly

The installation/assembly must be carried out by a professional who is authorised to do the work, and with due regard to the relevant regulations.

[fr] Instructions importantes pour l'installation/le montage

L'installation/le montage doit être effectué(e) par un spécialiste qualifié pour les opérations concernées et dans le respect des prescriptions applicables.

[bg] Важни указания във връзка с инсталацията/монтажа

Инсталацията/монтажът трябва да се извършва от лицензиран за работите специалист в съответствие с приложените разпоредби.

[cs] Důležité pokyny k instalaci/montáži

Instalaci/montáž musí při dodržení platných předpisů provést odborný pracovník s příslušným oprávněním pro tyto práce.

[da] Vigtige anvisninger til installationen/monteringen

Installationen/monteringen skal foretages af en godkendt installatør under overholdelse af de gældende forskrifter.

[el] Σημαντικές υποδείξεις για την εγκατάσταση/συναρμολόγηση

Η εγκατάσταση/συναρμολόγηση πρέπει να πραγματοποιείται από εξουσιοδοτημένο για τις εργασίες αυτές τεχνικό προσωπικό, το οποίο θα πρέπει να φροντίζει ώστε να τηρούνται οι ισχύουσες διατάξεις.

[es] Indicaciones importantes para instalación/montaje

La instalación/el montaje lo debe realizar personal especializado autorizado para los trabajos, respetando las prescripciones vigentes.

[et] Olulised juhised paigaldamiseks/montaažiks

Paigaldamist/montaaži tohib läbi viia selleks volitusi omav spetsialist, arvestades kehtivaid nõudeid.

[fi] Belangrijke aanwijzingen betreffende de installatie/montage

De installatie/montage moet worden uitgevoerd door een voor de werkzaamheden geautoriseerde installateur. Hij moet rekening houden met de geldende voorschriften.

[fr] Tärkeitä asennus- ja kokoonpano-ohjeita

Näihin töihin hyväksytyn ammattiasentajan pitää suorittaa asennus- ja kokoonpanotyöt voimassa olevien määräysten mukaisesti.

[hu] Fontos tudnivalók az installáláshoz/szereléshez

Az installálást/szerelést egy, a munkákra felhatalmazott szakembernek kell végeznie, az érvényes előírások figyelembevételével.

[it] Avvertenze importanti per l'installazione/il montaggio

L'installazione/il montaggio deve aver luogo ad opera di una ditta specializzata ed autorizzata in osservanza delle disposizioni vigenti.

[he] מניפולציות מותנהות על ידי הספקת/התקנת המוצר

התקנת המוצר/התקנת המוצר חייבת להיעשות על ידי מומחה מוסמך, תוך שמירה על כללי הבטיחות וההגנה הנדרשים.

[lt] Svarbios instaliavimo ir (arba) montavimo nuorodos

Instaliuoti ir montuoti, laikantis galiojančių taisyklių, leidžiama kvalifikuotiems specialistams, kurie buvo įgalioti šiems darbams atlikti.

[lv] Svarīgi norādījumi par iekārtas uzstādīšanu / montāžu

Iekārtas uzstādīšanu/montāžu ir jāveic specializētam sertificētam speciālistam, ievērojot spēkā esošos noteikumus.

[nl] Belangrijke aanwijzingen betreffende de installatie/montage

De installatie/montage moet worden uitgevoerd door een voor de werkzaamheden geautoriseerde installateur rekening houdend met de geldende voorschriften.

[no] Viktig informasjon om installasjon/montering

Installasjonen/monteringen skal gjennomføres av autoriserte installatører, og gjeldende forskrifter skal følges.

[pl] Ważne wskazówki dotyczące instalacji/montażu

Instalacja/montaż muszą być wykonane przez uprawnionego do tego rodzaju prac specjalistę przy zachowaniu obowiązujących przepisów.

[pt] Indicações importantes relativas à instalação/montagem

A instalação/montagem deve ser efetuada por um técnico especializado com qualificações para estes trabalhos, tendo em atenção os regulamentos em vigor.

[ro] Indicații importante privind instalarea/montajul

Instalarea/montajul trebuie realizate de către un specialist autorizat pentru lucrările respective, respectându-se prescripțiile valabile.

[ru] Важные указания по подключению/монтажу

Подключение/монтаж должны выполнять специалисты, имеющие допуск к выполнению таких работ, при соблюдении действующих норм и правил.

[sk] Dôležité pokyny týkajúce sa inštalácie/montáže

Inštaláciu/montáž musí realizovať odborník s oprávnením na výkon týchto prác, pričom musí dodržiavať platné predpisy.

[sl] Pomembni napotki za namestitvev/montažo

Namestitvev/montažo mora izvesti strokovnjak, pristojen za tovrstna dela, ob upošte vanju veljavnih predpisov.

[sr] Važna uputstva za ugradnju i montažu

Ugradnju i montažu moraju da obave samo stručna lica ovlašćena za izvođenje takvih radova koja će poštovati važeće propise.

[sv] Viktiga anvisningar för installation/montering

Installationen/monteringen måste utföras av en behörig och fackkunnig person enligt gällande föreskrifter.

[tr] Kurulum/Montaj ile ilgili önemli uyarılar

Kurulum/Montaj çalışmaları sadece yetkili bayiler tarafından aşağıda belirtilen talimatlar dikkate alınarak yapılmalıdır.

[uk] Важливі вказівки щодо установки/монтажу

Установку/монтаж мають здійснювати фахівці, що мають дозвіл на проведення цих робіт, із дотримання чинних приписів.

[zh] 安裝方面的重要提示

必须由受到许可承担该项工作的专业人员遵照相关法规进行安装。

[ar] ملاحظات هامة للتثبيت/التجميع

يجب أن يتم التثبيت/التجميع من قبل متخصص مصرح له بالعمل، مع مراعاة اللوائح السارية.

[fa] تذکرات مهم دربارہ نصب/مونٹاژ

نصب/مونٹاژ باید توسط فردی حرفه ای که مجاز به انجام این کار است، و همچنین با توجه کامل به مقررات مربوطه انجام شود.

Ersatzteilliste
Spare parts list

Liste des pièces de rechange
Lista parti di ricambio

Onderdelenlijst
Lista de repuestos

SE625/SE725

230kW - 20x - 1350/1710mm
 310kW - 27x - 1350/1710mm
 410kW - 32x - 1350/1890mm
 530kW - 42x - 1500/1890mm
 690kW - 52x - 1650/1890mm
 870kW - 58x - 1650/2120mm
 1070kW - 64x - 1650/2240mm
 1320kW - 83x - 1650/2240mm
 1600kW - 103x - 1650/2340mm

SK625/SK725

230kW - 20x - 1000/1710mm
 310kW - 27x - 1000/1710mm
 410kW - 34x - 1150/1890mm
 530kW - 42x - 1150/1890mm
 690kW - 52x - 1150/1890mm
 870kW - 67x < 31.01.1998 - 1100/2120mm
 870kW - 58x > 01.02.1998 - 1250/2120mm
 1070kW - 64x - 1250/2240mm
 1320kW - 83x - 1250/2240mm
 1600kW - 103x - 1250/2340mm

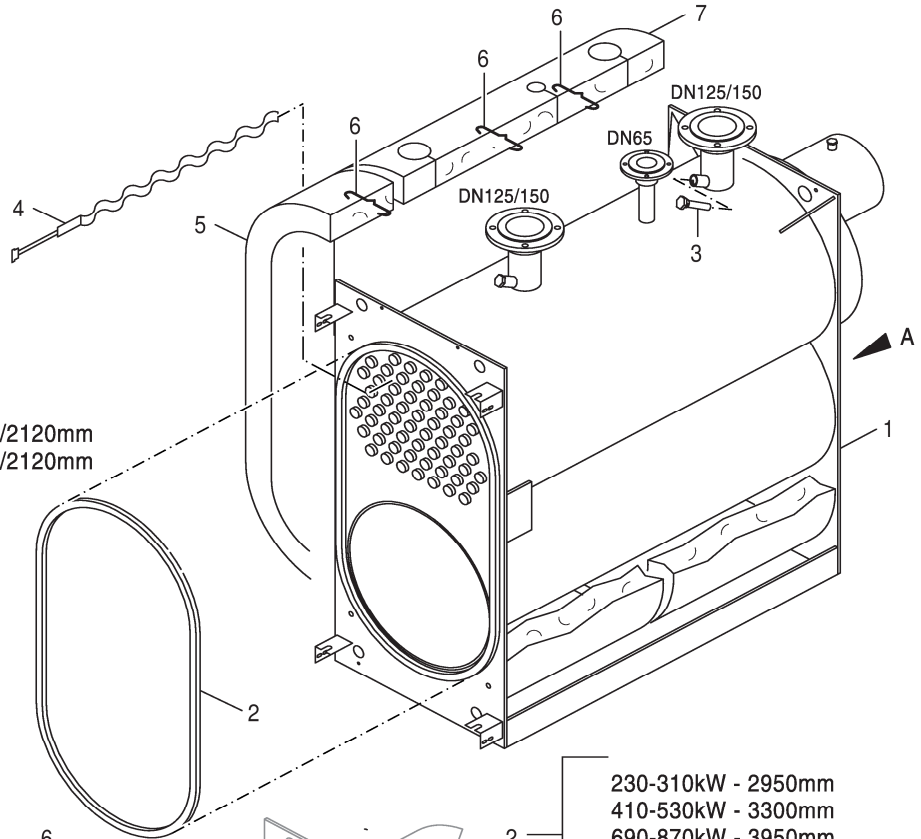

Ansicht A
180° gedreht

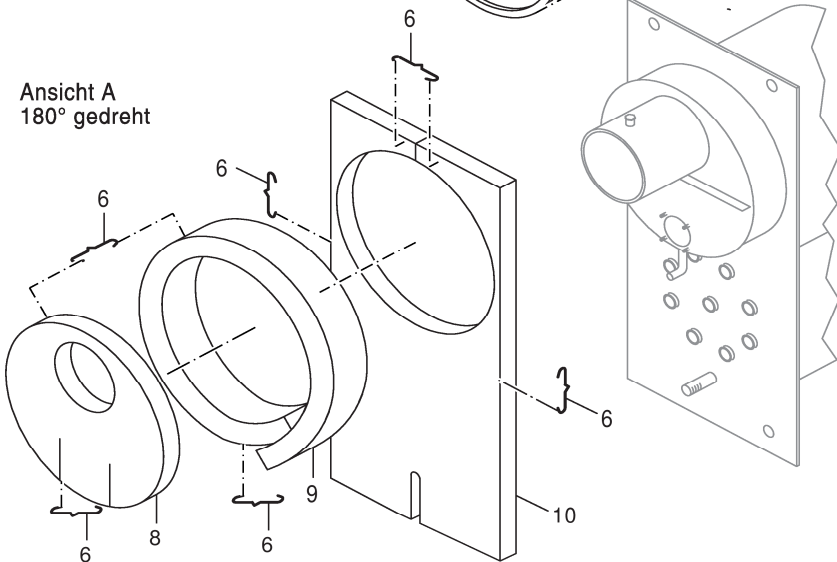

230-310kW - 2950mm
 410-530kW - 3300mm
 690-870kW - 3950mm
 1070-1320kW - 4750mm
 1600kW - 5100mm

99906986.ab.RS-Kesselblock SE/SK625-SE/SK725

1 Kesselblock SE/SK 625/725
 Boiler block SE/SK 625/725
 Corps de chauffe SE/SK 625/725
 Corpo caldaia SE/SK 625/725
 Ketelblok SE/SK 625/725
 Cuerpo de caldera SE/SK 625/725

SE625 / SE725

Pos	Bezeichnung Description Dénomination Descrizioni Benaming Descripción	Bestell-Nr. Ordering no. Numéro de commande N° d'ordine Bestelnummer Número el ordenar	SE625-230	SE625-310	SE625-410	SE625-530	SE625-690	SE725-870	SE725-1070	SE725-1070 S	SE725-1320	SE725-1320 S	SE725-1600	SE725-1600 S				Bemerkungen Remarks Remarques Osservazioni Opmerkingen Observaciones
2	Dichtschnur 20x25x3120mm lang	7057042	■	■														230-310KW
2	Dichtschnur 20x25x3520mm lang	7057044			■	■												410-530KW
2	Dichtschnur 20x25x4050mm lang	7057048					■	■										690-870KW
2	Dichtschnur 20x25x5100mm	9556026							■	■	■	■	■	■				690-870KW
3	Tauchhülse R 3/4"x150mm	5446085	■	■	■	■	■	■	■	■	■	■	■	■				
4	Turbulator 1350/1710 mm lang SE625	5059280	■	■														230-310KW
4	Turbulator 1350/1890 mm lang SE625	5059284			■													410KW
4	Turbulator 1500/1890 mm lang SE625	5059282				■												530KW
4	Turbulator 1650/1890 mm lang SE625	5059286					■											690KW
4	Turbulator 1650/2120 mm lang SE725	5059290						■										690KW
4	Turbulator 1650/2240 mm lang SE725	5059292							■	■	■	■						690KW
4	Turbulator 1650/2340 mm lang SE725	5059294											■	■				690KW
5	Wärmeschutz Teil2 S625-230/310	5782922	■	■														
5	Wärmeschutz Teil2 S625-410/530	5782932			■	■												
5	Wärmeschutz Teil2 S625-690	5782936					■											
5	Wärmeschutz Teil2 S725-870	5782938						■										
5	Wärmeschutz Teil2 S725-1070/1320	5782890							■	■	■	■						
5	Wärmeschutz Teil2 S725-1600	5782984											■	■				
6	Haltefeder (10x)	7 747 016 084	■	■	■	■	■	■	■	■	■	■	■	■				
7	Wärmeschutz Teil1 S625-230/310	5782920	■	■														
7	Wärmeschutz Teil1 S625 410/530	5782930			■	■												
7	Wärmeschutz Teil1 S625-690	5782731					■											
7	Wärmeschutz Teil1 S725-870	5782879						■										
7	Wärmeschutz Teil1 S725-1070/1320	5782888							■	■	■	■						
7	Wärmeschutz Teil1 S725-1600	5782982											■	■				
8	Wärmeschutz Teil5 S625-230/310	5782928	■	■														
8	Wärmeschutz Teil5 S625-410/530	5782722			■	■												
8	Wärmeschutz Teil5 S625-690	5782727					■											
8	Wärmeschutz Teil5 S725-870	5782886						■										
8	Wärmeschutz Teil5 S725-1070/1320	5782896							■	■	■	■						
8	Wärmeschutz Teil5 S725-1600	5782906											■	■				
9	Wärmeschutz Teil3 S625-230/310	5782924	■	■														
9	Wärmeschutz Teil3 S625-410/530	5782934			■	■												
9	Wärmeschutz Teil3 S625-690	5782725					■											
9	Wärmeschutz Teil3 S725-870	5782882						■										
9	Wärmeschutz Teil3 S725-1070/1320	5782892							■	■	■	■						
9	Wärmeschutz Teil3 S725-1600	5782902											■	■				
10	Wärmeschutz Teil4 S625-230/310	5782926	■	■														
10	Wärmeschutz Teil4 S625-410/530	5782721			■	■												
10	Wärmeschutz Teil4 S625-690	5782726					■											
10	Wärmeschutz Teil4 S725-870	5782884						■										
10	Wärmeschutz Teil4 S725-1070/1320	5782894							■	■	■	■						
10	Wärmeschutz Teil4 S725-1600	5782904											■	■				

SE625 / SE725

Kesselblock SE/SK 625/725
 Boiler block SE/SK 625/725
 Corps de chauffe SE/SK 625/725
 Corpo caldaia SE/SK 625/725
 Ketelblok SE/SK 625/725
 Cuerpo de caldera SE/SK 625/725

1

Ersatzteilliste
Spare parts list

Liste des pièces de rechange
Lista parti di ricambio

Onderdelenlijst
Lista de repuestos

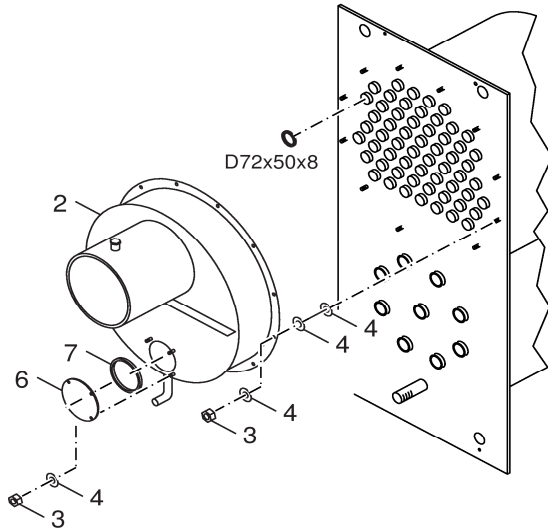

Hinweis:
Bei Defekt der Dichtung D72x50x8mm bitte
Austausch-Abgassammler Pos. 9 bestellen

Notes for the user:
The faulty sealing D72x50x8mm, please order
exchange-waste gas collector position No. 9

SK625/725
< 05/99
Serienstand 00
Series version 00

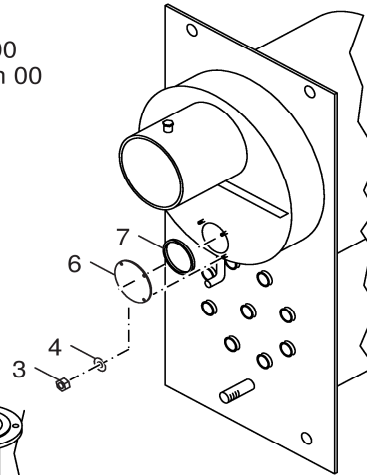

SK625/725
> 05/99
Serienstand 01
Series version 01

Abgassammler Rückwand
(wird bei Austausch an die
Heizgasrohre angeschweißt)

Waste gas collector rear panel
(is welded on by exchange
on the heating gas pipes)

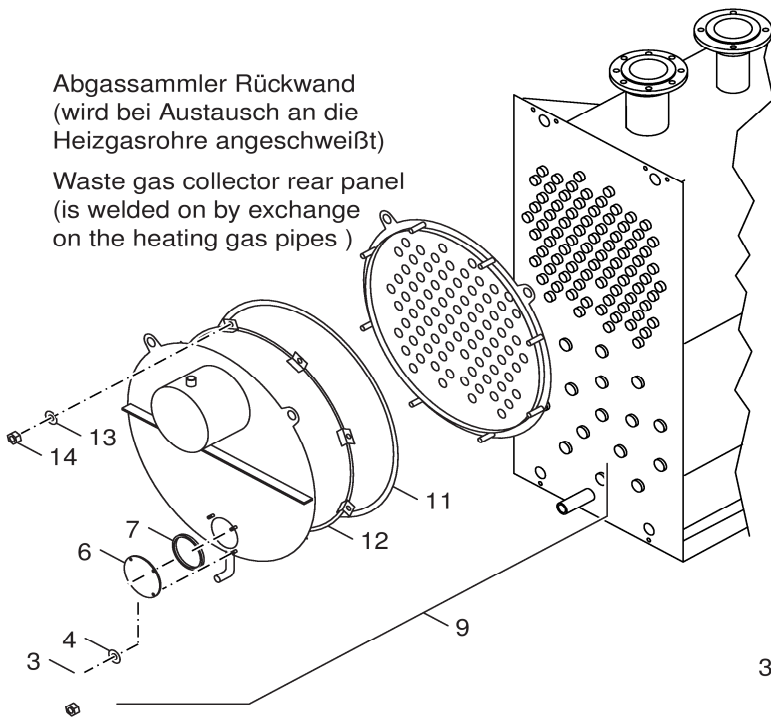

SE625/725
< 05/99
Serienstand 00
Series version 00

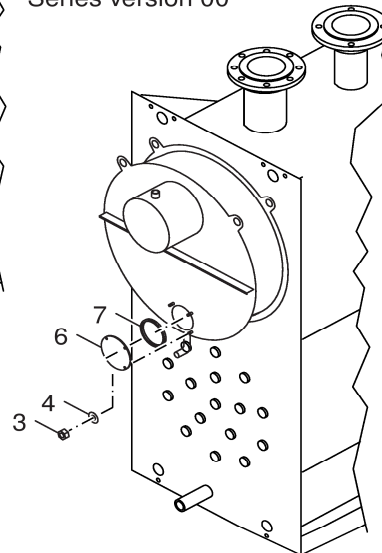

SE625/725
> 05/99
Serienstand 01
Series version 01

99908163.aa.RS-Abgassammler SE/SK625/725

2

Abgassammler SE/SK 625/725
exhaust collector SE/SK 625/725
Coupe-tirage anti-refouleur SE/SK625/725
Collettore combusti SE/SK 625/725
Rookgascollector SE/SK 625/725
Colector de gases de escape SE/SK625/725

SE625 / SE725

Pos	Bezeichnung Description Dénomination Descrizioni Benaming Descripción	Bestell-Nr. Ordering no. Número de commande N° d'ordine Bestelnummer Número el ordenar	SE625-230	SE625-310	SE625-410	SE625-530	SE625-690	SE725-870	SE725-1070	SE725-1070 S	SE725-1320	SE725-1320 S	SE725-1600	SE725-1600 S				Bemerkungen Remarks Remarques Osservazioni Opmerkingen Observaciones
3	6kt-Mutter ISO4032 M8 8 A3K	82585180	■	■	■	■	■	■	■	■	■	■	■	■				
4	Unterlegscheibe ISO 7089 A8,4 A3K (10x)	8 718 571 269 0	■	■	■	■	■	■	■	■	■	■	■	■				
6	Reinigungsdeckel S625/725 D178	63022146	■	■	■	■	■	■	■	■	■	■	■	■				
7	Dichtung D148X132X8 GP Reinigungsdeckel	63001614	■	■	■	■	■	■	■	■	■	■	■	■				
9	Abgassammler SE625-230 A kpl	67902921	■															
9	Abgassammler SE625-310 A kpl	67902922		■														
9	Abgassammler SE625-410 A kpl	67902923			■													
9	Abgassammler SE625-530 A kpl	67902924				■												
9	Abgassammler SE625-690 A kpl	67902925					■											
9	Abgassammler SE725-870 A kpl	67902929						■										
9	Abgassammler SE725-1070 A kpl	67902926							■	■	■	■						
9	Abgassammler SE725-1600 A kpl	67902928												■	■			
11	Dichtschnur 18x3300 GP	63020974	■	■	■	■	■	■	■	■	■	■	■	■				
12	Abgassammler SE625-230/310 A geschw	63001224	■	■														
12	Abgassammler SE625-410/530 A geschw	63001227			■	■												
12	Abgassammler SE625/725-690/870 A geschw	63001228					■	■										
12	Abgassammler SE725-1070/1320 A geschw	63001231							■	■	■	■						
12	Abgassammler SE725-1600 A geschw	63001232												■	■			
13	Unterlegscheibe ISO 7089 10,5x2 (10x)	8 718 571 270 0	■	■	■	■	■	■	■	■	■	■	■	■				
14	6kt-Mutter ISO4032 M10 8 A3K (4x)	8 718 583 603	■	■	■	■	■	■	■	■	■	■	■	■				

SE625 / SE725

Abgassammler SE/SK 625/725
exhaust collector SE/SK 625/725
Coupe-tirage anti-refouleur SE/SK625/725
Collettore combusti SE/SK 625/725
Rookgascollector SE/SK 625/725
Colector de gases de escape SE/SK625/725

Ersatzteilliste
Spare parts list

Liste des pièces de rechange
Lista parti di ricambio

Onderdelenlijst
Lista de repuestos

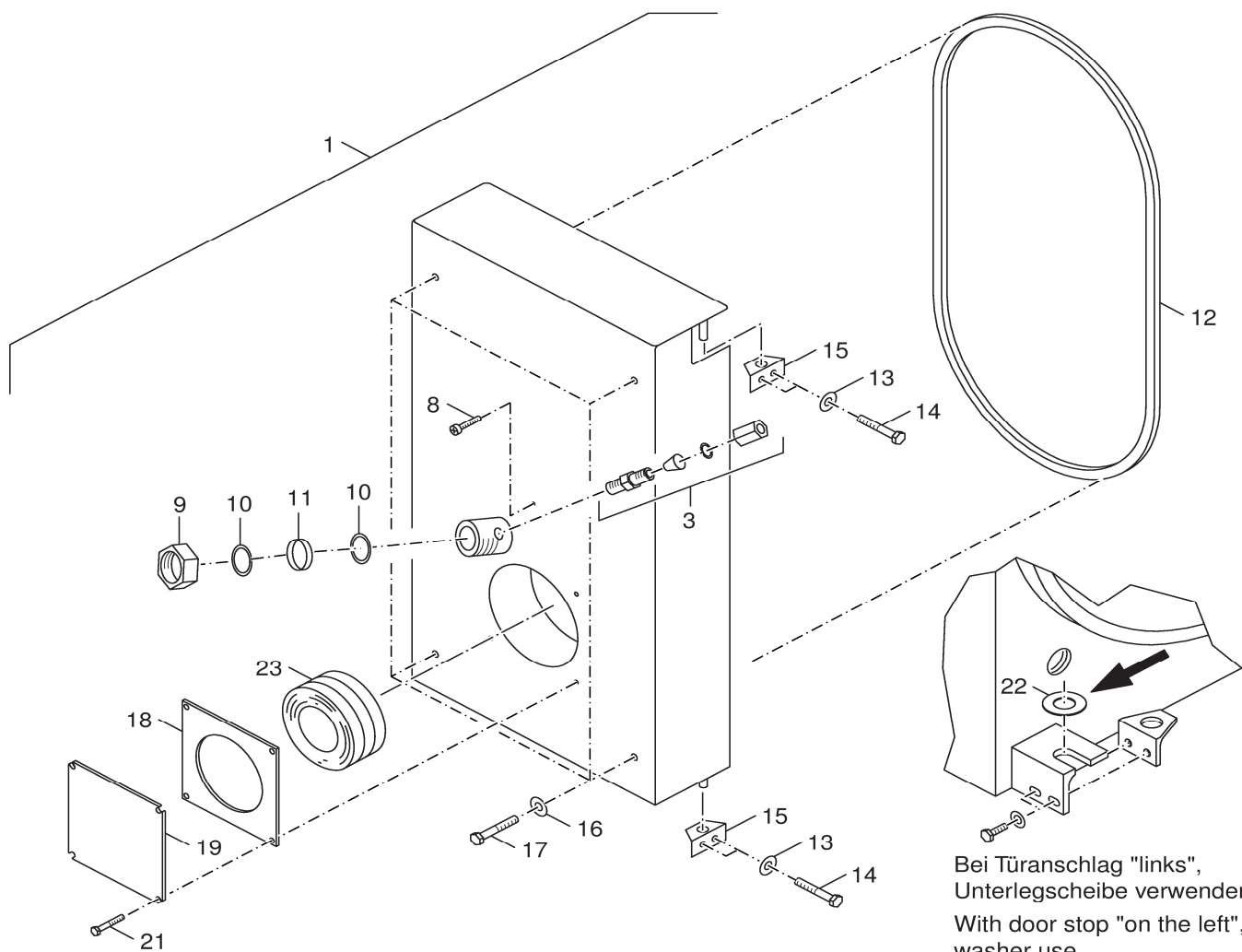

Typ	Leistung in kW		Typ	Leistung in kW	Typ	Leistung in kW
SE/SK625	230	ersetzt to replace	S625	210		
SE/SK625	310		S625	270		
SE/SK625	410		S625	370		
SE/SK625	530		S625	480		
SE/SK625	690		S625	600		
SE/SK725	870		S725	750	SB725	770
SE/SK725	1070		S725	920	SB725	950
SE/SK725	1320		S725	1150	SB725	1200
SE/SK725	1600		S725	1350	SB725	1500

99909000.aa.RS-Brennertür SE/SK625/725

3

Brennertür SE/SK 625/725
Burner door SE/SK 625/725
Porte de brûleur SE/SK 625/725
Porta del bruciatore SE/SK 625/725
Branderdeur SE/SK 625/725
Puerta del quemador SE/SK 625/725

SE625 / SE725

Pos	Bezeichnung Description Dénomination Descrizioni Benaming Descripción	Bestell-Nr. Ordering no. Numéro de commande N° d'ordine Bestelnummer Número el ordenar	SE625-230	SE625-310	SE625-410	SE625-530	SE625-690	SE725-870	SE725-1070	SE725-1070 S	SE725-1320	SE725-1320 S	SE725-1600	SE725-1600 S				Bemerkungen Remarks Remarques Osservazioni Opmerkingen Observaciones
1	Brennertür S625-230/310 kpl	5806370	■	■														
1	Brennertür S625-410/530 kpl	5806372			■	■												
1	Brennertür S625/S725-690/870	5806374					■	■										
1	Brennertür S725-1070/1320	5806376							■	■	■	■						
1	Brennertür S725-1600	5806378											■	■				
3	Einschraubversch. GE 10-Ir Ermeto	8 718 584 411	■	■	■	■	■	■	■	■	■	■	■	■				
8	Schneidschraube DIN7516 A M5x10 A3K	5278060	■	■	■	■	■	■	■	■	■	■	■	■				FD >23.10.2000
9	Überwurfmutter 4374 2"	328950	■	■	■	■	■	■	■	■	■	■	■	■				FD <18.11.1996
9	Überwurfmutter G1 1/2"x19 Ms	8 718 585 261	■	■	■	■	■	■	■	■	■	■	■	■				FD <18.11.1996,FD >19.11.1996
10	Dichtring DIN7603 A 50x57	7057260	■	■	■	■	■	■	■	■	■	■	■	■				FD <18.11.1996,FD >19.11.1996
10	Dichtring 39x45x2mm	7057264	■	■	■	■	■	■	■	■	■	■	■	■				FD <18.11.1996,FD >19.11.1996
11	Schauglas D55x5mm	7 747 026 280	■	■	■	■	■	■	■	■	■	■	■	■				FD <18.11.1996,FD >19.11.1996
11	Schauglas 44 S=4,5-5,5 (1x)	7 747 026 281	■	■	■	■	■	■	■	■	■	■	■	■				FD >19.11.1996
12	Dichtschnur D30x3120mm lang	7057062	■	■														230-310kW, auf 2950mm ablängen
12	Dichtschnur D30x3720mm	7057066			■	■												410-530kW, auf 3300mm ablängen
12	Dichtschnur D30x4050mm lang	7057068					■	■										690-870kW, auf 3950mm ablängen
12	Dichtschnur D30x5100mm lang	9556025							■	■	■	■	■	■				690-870kW, auf 3950mm ablängen
13	Scheibe ISO 7089 A17 A3K (2x)	8 718 584 403	■	■	■	■	■	■	■	■	■	■	■	■				
14	6kt-Schraube DIN6921 M10x25 (10x)	8 718 575 500 0	■	■	■	■	■	■	■	■	■	■	■	■				
15	Scharnierteil II	20002315	■	■	■	■	■	■	■	■	■	■	■	■				
16	Scheibe DIN7349 17 A3K (10x)	8 718 577 728 0	■	■	■	■	■	■	■	■	■	■	■	■				
17	6kt-Schraube ISO4014 M16x280 8.8 A3K	5090162	■	■														230-310KW
17	6kt-Schraube ISO4014 M16x320 8.8 A3K	5090170			■	■												410-530KW
17	6kt-Schraube ISO4014 M16x380 8.8 A3K	5090164					■	■	■	■	■	■	■	■				690-1600KW
18	Dichtung Brpl S625-230/310	63031752	■	■														
18	Dichtung Brennerplatte 338x338x8mm	63031753			■	■	■	■										410-870KW
18	Dichtung Brennerpl 430x430x8 S725	63031751							■	■	■	■	■	■				410-870KW
19	Brennerplatte ungebohrt 10x298x298mm	8 718 575 189	■	■														230-310KW
19	Brennerplatte ungebohrt 10x338x338mm	63025209			■	■	■	■										410-870KW
19	Brennerplatte Standart (blind)430x430x10	7057296							■	■	■	■	■	■				410-870KW
21	6kt-Schraube ISO4017 M12x45 (10x)	8 718 575 468 0	■	■	■	■	■	■	■	■	■	■	■	■				
22	Scheibe ISO 7089-A13-A3K (5x)	8 718 584 413	■	■	■	■	■	■	■	■	■	■	■	■				
23	Isoliering Br-Tür S625-230/310 verp	63009441	■	■														
23	Isoliering-Set Br-Tür S625-410/530 verp	63009442			■	■												
23	Isoliering Br-Tür S625/725 690-1600verp	63009443					■	■	■	■	■	■	■	■				690-1600KW
	Reparaturmasse Calde Stix14 G3, 25kg	63006405	■	■	■	■	■	■	■	■	■	■	■	■				Nur für WKD !!!!!!!
	Lacksprühdose RAL5015 150ml (himmelblau)	8 718 576 634 0	■	■	■	■	■	■	■	■	■	■	■	■				Buderus blau
	Reparaturmasse Fibrefrax 140 - 300ml	8 732 908 640	■	■	■	■	■	■	■	■	■	■	■	■				Nur für WKD !!!!!!!

SE625 / SE725

Brennertür SE/SK 625/725
 Burner door SE/SK 625/725
 Porte de brûleur SE/SK 625/725
 Porta del bruciatore SE/SK 625/725
 Branderdeur SE/SK 625/725
 Puerta del quemador SE/SK 625/725

3

Ersatzteilliste
Spare parts list

Liste des pièces de rechange
Lista parti di ricambio

Onderdelenlijst
Lista de repuestos

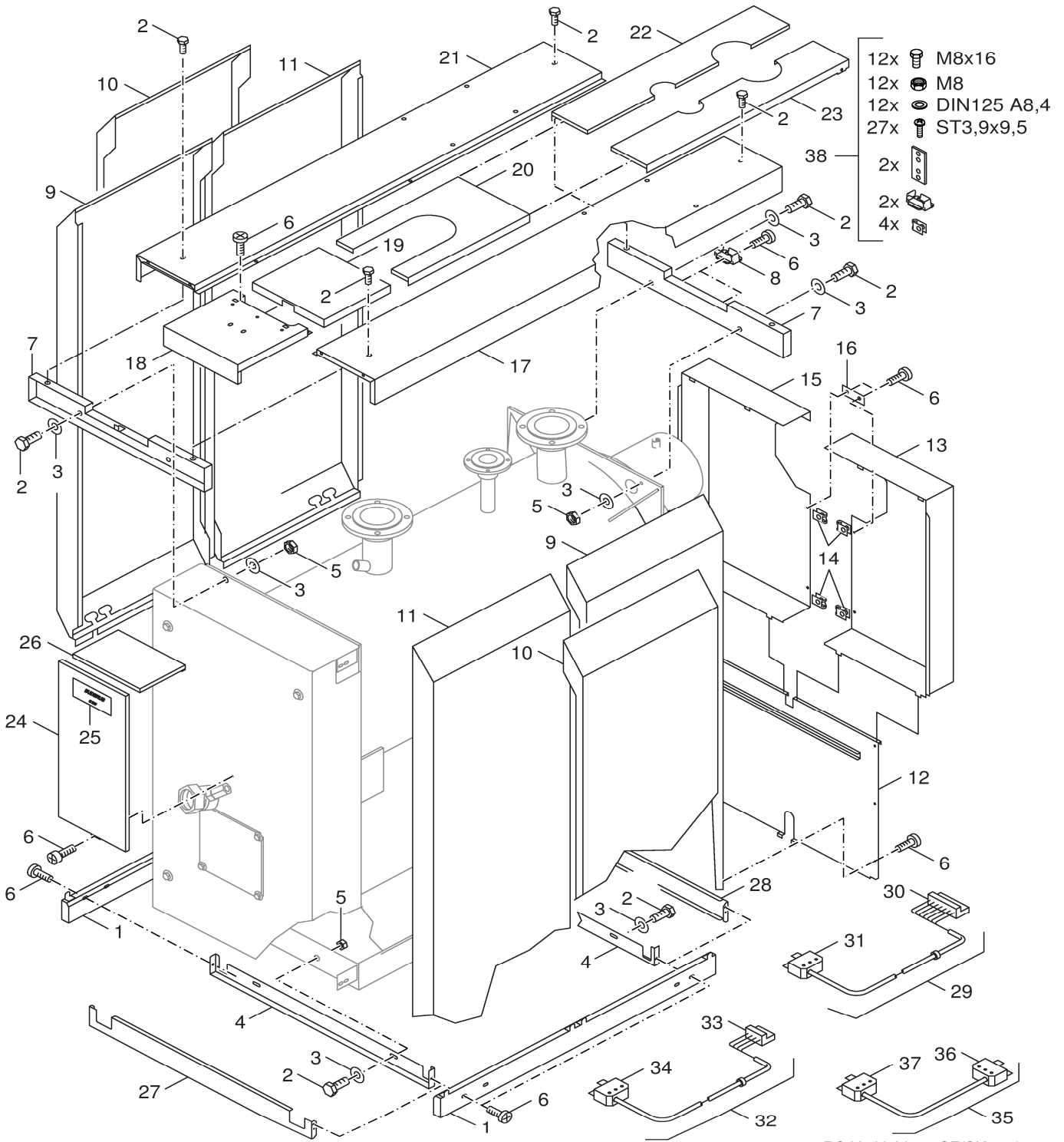

4
Verkleidung SE/SK 625/725
Casing SE/SK 625/725
Carénage SE/SK 625/725
Rivestimento SE/SK 625/725
Bekleding SE/SK 625/725
Revestimiento SE/SK 625/725

SE625 / SE725

Pos	Bezeichnung Description Dénomination Descrizioni Benaming Descripción	Bestell-Nr. Ordering no. Numéro de commande N° d'ordine Bestelnummer Número el ordenar	SE625-230	SE625-310	SE625-410	SE625-530	SE625-690	SE725-870	SE725-1070	SE725-1070 S	SE725-1320	SE725-1320 S	SE725-1600	SE725-1600 S				Bemerkungen Remarks Remarques Osservazioni Opmerkingen Observaciones
1	Socket längs lackiert S625-230/310	5158460	■	■														
1	Socket längs lackiert S625-410/530/690	5158462			■	■	■											
1	Socket längs lackiert S725-870	5785460						■										
1	Socket längs lackiert S725-1070/1320	5785462							■	■	■	■						
1	Socket längs lackiert S725-1600	5785464											■	■				
2	Schraube M8x16 (4x)	8 718 584 325	■	■	■	■	■	■	■	■	■	■	■	■				
3	Unterlegscheibe ISO 7089 A8,4 A3K (10x)	8 718 571 269 0	■	■	■	■	■	■	■	■	■	■	■	■				
4	Traverse unten vo/hi S625 230-310kW	5158437	■	■														
4	Traverse unten vo/hi S625 410-530kW	5158439			■	■												
4	Traverse unten vo/hi S625/S725 690-870KW	5158440					■	■										
4	Traverse unten vo/hi S725 V2 1070-1320kW	63007727							■	■	■	■						
4	Traverse unten vo/hi S725 V2 1600kW	63007728											■	■				
5	6kt-Mutter ISO4032 M8 8 A3K	82585180	■	■	■	■	■	■	■	■	■	■	■	■				
6	Flachkopfschraube ST3,9x9,5 A3T (10x)	7 747 026 999	■	■	■	■	■	■	■	■	■	■	■	■				
7	Traverse ob S625-230/310	5158442	■	■														
7	Traverse ob S625-410/530	5158444			■	■												
7	Traverse ob S625-690/S725-870	5158448					■	■										
7	Traverse ob S725-1070/1320	5785454							■	■	■	■						
7	Traverse ob S725-1600	5785456											■	■				
8	Kabelhalter (5x)	8 718 584 331	■	■	■	■	■	■	■	■	■	■	■	■				
9	Seitenwand li S625-230/310	5158600	■	■														
9	Seitenwand li S625-410/530	5158604			■	■												
9	Seitenwand li S625-690 S725-870	5158608					■	■										
9	Seitenwand li S725-1070/1320	5785570							■	■	■	■						
9	Seitenwand li S725-1600	5785574											■	■				
10	Seitenwand mi S625-410/530 lackiert	5158370			■	■												
10	Seitenwand mi S625-690 lackiert	5158372					■											
10	Seitenwand mi S725-870 lackiert	5785400						■										
10	Seitenwand mi S725-1070/1320 lackiert	5785402							■	■	■	■						
10	Seitenwand mi S725-1600 lackiert	5785404											■	■				
11	Seitenwand re S625-230/310	5158602	■	■														
11	Seitenwand re S625-410/530	5158606			■	■												
11	Seitenwand re S625-690 S725-870	5158610					■	■										
11	Seitenwand re S725-1070/1320	5785572							■	■	■	■						
11	Seitenwand re S725-1600	5785576											■	■				
12	Rückwand un S625-230/310	5158374	■	■														
12	Rückwand un S625-410/530	5158376			■	■												
12	Rückwand un S625-690 S725-870	5158378					■	■										
12	Rückwand un S725-1070/1320	5785406							■	■	■	■						
12	Rückwand un S725-1600	5785408											■	■				
13	Rückwand ob re S625-230/310	5158382	■	■														
13	Rückwand ob re S625-410/530	5158386			■	■												
13	Rückwand ob re S625-690 S725-870	5158390					■	■										
13	Rückwand ob re S725-1070/1320	5785410							■	■	■	■						
13	Rückwand ob re S725-1600	5785414											■	■				
14	Schnappmutter 3,9-A3K_SNU5743	8 718 585 260	■	■	■	■	■	■	■	■	■	■	■	■				
15	Rückwand ob li S625-230/310	5158380	■	■														
15	Rückwand ob li S625-410/530	5158384			■	■												
15	Rückwand ob li S625-690 S725-870	5158388					■	■										
15	Rückwand ob li S725-1070/1320	5785412							■	■	■	■						
15	Rückwand ob li S725-1600	5785416											■	■				
16	Verbindungsflasche 80x30x0,75	63001624	■	■	■	■	■	■	■	■	■	■	■	■				
SE625 / SE725									Verkleidung SE/SK 625/725 Casing SE/SK 625/725 Carénage SE/SK 625/725 Rivestimento SE/SK 625/725 Bekleding SE/SK 625/725 Revestimiento SE/SK 625/725									4

Ersatzteilliste
Spare parts list

Liste des pièces de rechange
Lista parti di ricambio

Onderdelenlijst
Lista de repuestos

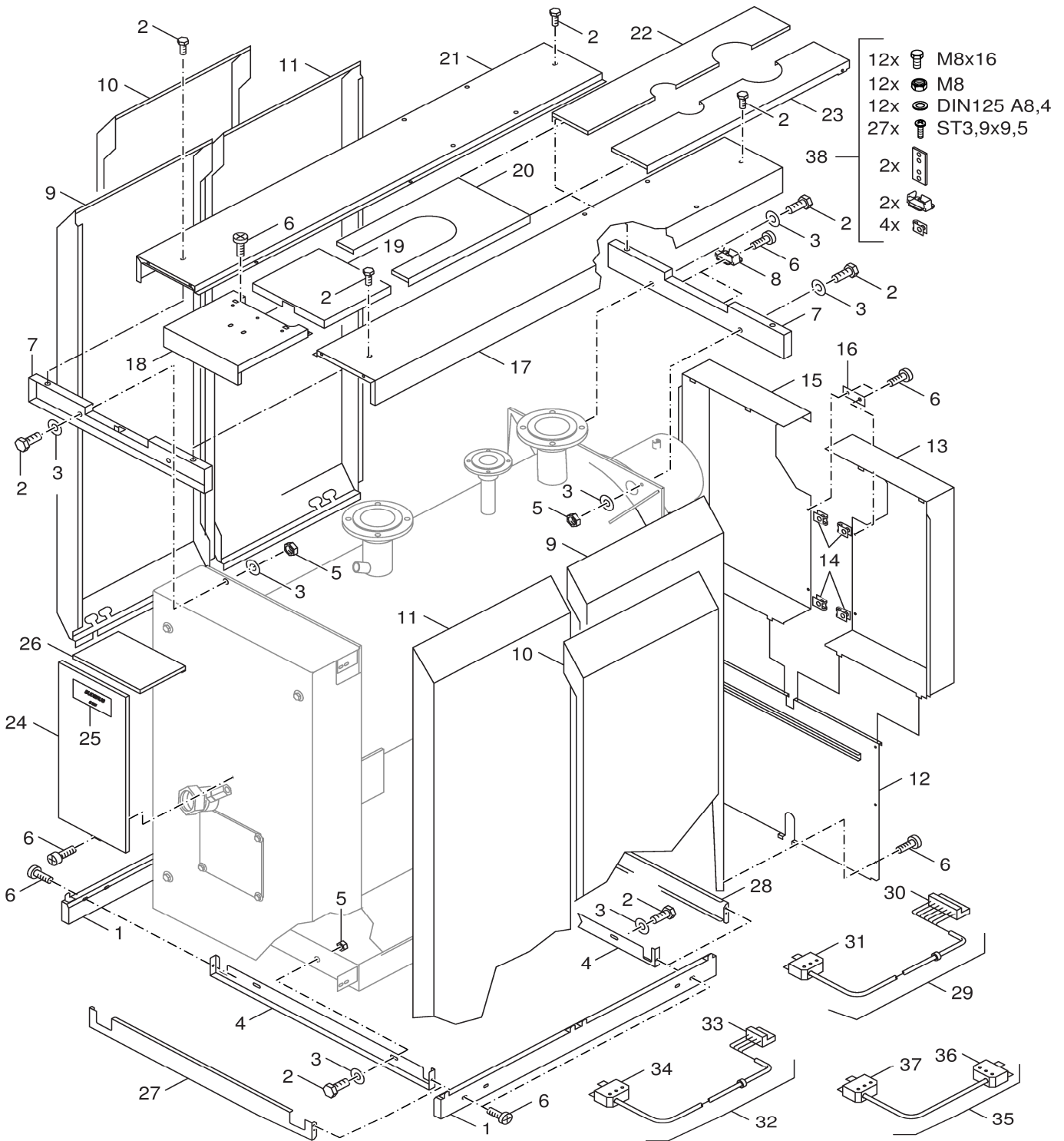

99907096.aa.RS-Verkleidung SE/SK625/725

4

Verkleidung SE/SK 625/725
Casing SE/SK 625/725
Carénage SE/SK 625/725
Rivestimento SE/SK 625/725
Bekleding SE/SK 625/725
Revestimiento SE/SK 625/725

SE625 / SE725

Pos	Bezeichnung Description Dénomination Descrizioni Benaming Descripción	Bestell-Nr. Ordering no. Numéro de commande N° d'ordine Bestelnummer Número el ordenar	SE625-230	SE625-310	SE625-410	SE625-530	SE625-690	SE725-870	SE725-1070	SE725-1070 S	SE725-1320	SE725-1320 S	SE725-1600	SE725-1600 S			Bemerkungen Remarks Remarques Osservazioni Opmerkingen Observaciones
17	Abdeckblech rechts S625 230- 310KW	5158478	■	■													
17	Abdeckblech rechts S625 410- 530KW	5158482			■	■											
17	Abdeckblech rechts S625 690kW	5158540					■										
17	Abdeckblech rechts S725 870kW	5158542						■									
17	Abdeckblech rechts S725-1070-1320kW	5158544							■	■	■	■					
17	Abdeckblech rechts S725-1600kW	5785490											■	■			
18	Haube vo S625-230/310/410/530 lackiert	5158392	■	■	■	■											
18	Haube vo S625-690 S725-870-1600lackiert	5158394					■	■	■	■	■	■	■	■			
19	Haube mitte S625 230-690kW	8 718 577 723 0	■	■	■	■	■										
19	Haube mitte S725 870-1600kW	8 718 577 727 0						■	■	■	■	■	■	■			
20	Haube hi S625-230/310 lackiert	5158410	■	■													
20	Haube hi S625-410-530 lackiert	5158412			■	■											
21	Abdeckblech links S625 230-310KW	5158476	■	■													
21	Abdeckblech links S625 410-530KW	5158480			■	■											
21	Abdeckblech links S625 690kW	5158530					■										
21	Abdeckblech links S725 870kW	5158532						■									
21	Abdeckblech links S725 1070-1320kW	5158534							■	■	■	■					
21	Abdeckblech links S725 1600kW	5785488											■	■			
22	Haube hi li S625-690/S725-870 geteilt	5158564					■	■									
22	Haube hi li S625-230/530 geteilt kpl	5158568	■	■	■	■											
22	Haube hi li S725-1070/1320 geteilt	5785542							■	■	■	■					
22	Haube hi li S725-1600 geteilt	5785544											■	■			
23	Haube hi re S625-690/S725-870 geteilt	5158566					■	■									
23	Haube hi re S625-230/530 geteilt kpl	5158570	■	■	■	■											
23	Haube hi re S725-1070/1320 geteilt	5785548							■	■	■	■					
23	Haube hi re S725-1600 geteilt	5785550											■	■			
24	Blende ob I S625-230/310/410/530 lack	5158428	■	■	■	■											FD <01.10.1996
24	Blende ob I S625-690/S725-870 lack	5158434					■	■									FD <01.10.1996
24	Blende S625 230-530KW	5158500	■	■	■	■											
24	Blende S625-690 S725-870	5158502					■	■									
24	Blende S725-1070/1320	5158504							■	■	■	■					
24	Blende S725-1600	5158506											■	■			FD <01.10.1996
24	Blende ob I S725-1070/1320 lack	5785444							■	■	■	■					FD <01.10.1996
24	Blende ob I S725-1600 lack	5785446											■	■			
25	Geräteschild Logano SE625	67902832	■	■	■	■	■										FD >01.04.1999
25	Geräteschild Logano SE725	67902833						■	■	■	■	■	■	■			FD >01.04.1999
25	Geräteschild Logano plus SE625	67902850	■	■	■	■	■										
25	Geräteschild Logano plus SE725	67902852						■	■	■	■	■	■	■			
26	Blende ob II S625-230/310/410/530 lack	5158432	■	■	■	■											FD <01.10.1996
26	Blende ob II S625-690/S725-870 lack	5158430					■	■									FD <01.10.1996
26	Blende ob II S725-920/1350 lack	5785440							■	■	■	■					FD <01.10.1996
27	Sockel vo lackiert S625-230/310	5158464	■	■													
27	Sockel vo lackiert S625-410/530	5158466			■	■											
27	Sockel vo lackiert S625-690/S725-870	5158468					■										
27	Sockel vo lackiert S725-870	5785466						■									
27	Sockel vo lackiert S725-1070/1320	5785468							■	■	■	■					
27	Sockel vo lackiert S725-1600	5785470											■	■			FD <01.10.1996
28	Sockel hi lackiert S625-230/310	5158470	■	■													
28	Sockel hi lackiert S625-410/530	5158472			■	■											
28	Sockel hi lackiert S625-690, S725-870	5158474					■										
28	Sockel hi lackiert S725-870	5785472						■									
28	Sockel hi lackiert S725-1070/1320	5785474							■	■	■	■					
SE625 / SE725									Verkleidung SE/SK 625/725 Casing SE/SK 625/725 Carénage SE/SK 625/725 Rivestimento SE/SK 625/725 Bekleding SE/SK 625/725 Revestimiento SE/SK 625/725							4	

Ersatzteilliste
Spare parts list

Liste des pièces de rechange
Lista parti di ricambio

Onderdelenlijst
Lista de repuestos

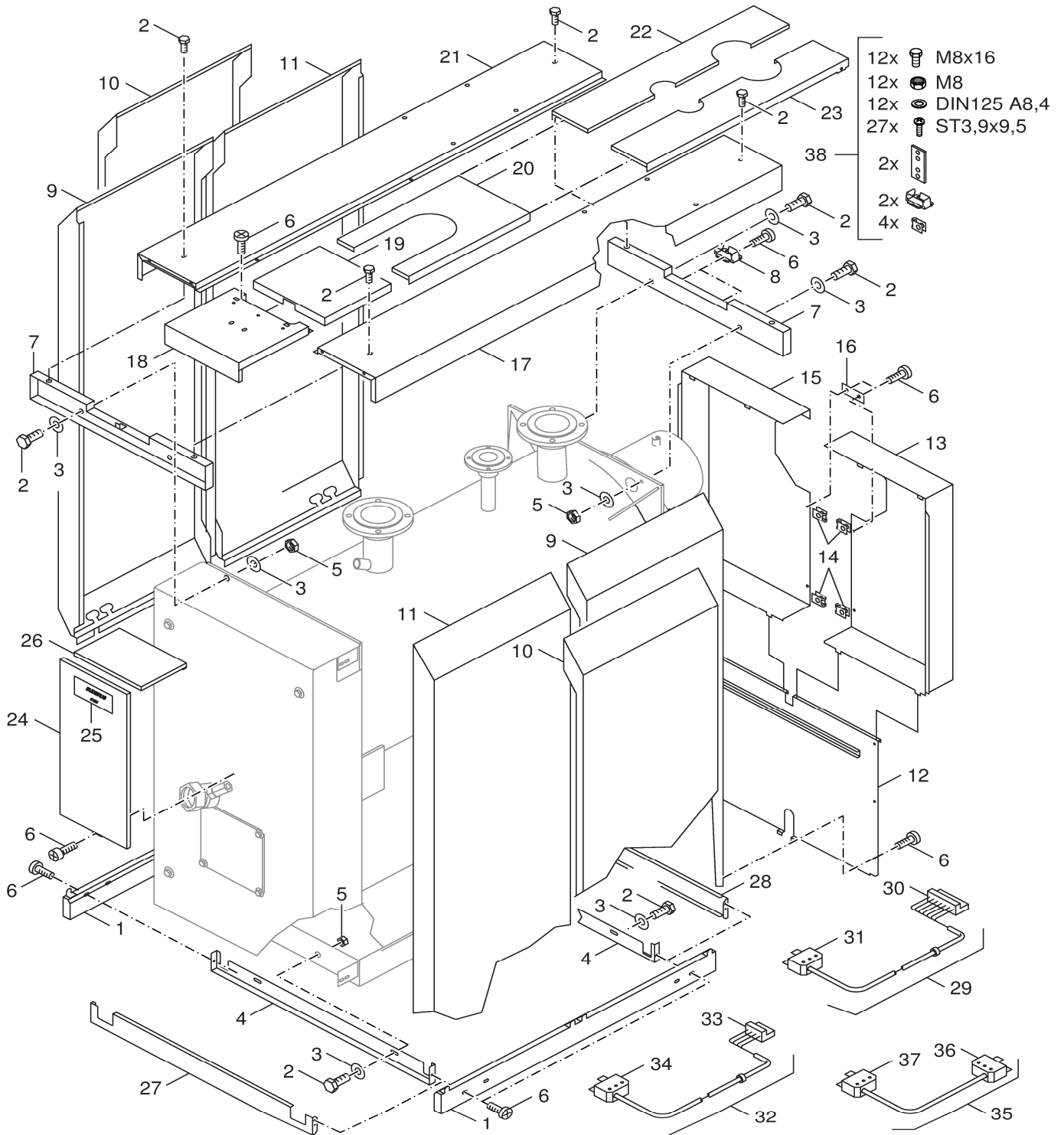

4

Verkleidung SE/SK 625/725
Casing SE/SK 625/725
Carénage SE/SK 625/725
Rivestimento SE/SK 625/725
Bekleding SE/SK 625/725
Revestimiento SE/SK 625/725

SE625 / SE725

Pos	Bezeichnung Description Dénomination Descrizioni Benaming Descripción	Bestell-Nr. Ordering no. Numéro de commande N° d'ordine Bestelnummer Número el ordenar	SE625-230	SE625-310	SE625-410	SE625-530	SE625-690	SE725-870	SE725-1070	SE725-1070 S	SE725-1320	SE725-1320 S	SE725-1600	SE725-1600 S				Bemerkungen Remarks Remarques Osservazioni Opmerkingen Observaciones
28	Socket hi lackiert S725-1600	5785476											■	■				
29	Brennerleitung 5000	7060994	■	■	■	■												230-530KW
29	Brennerleitung 8000	7060996					■	■	■	■	■	■	■	■				690-1600KW
30	Anschlussklemme 7-polig BR I grün	7 747 023 989	■	■	■	■	■	■	■	■	■	■	■	■				690-1600KW
31	Steckerteil ST18/7 versilbert	67903164	■	■	■	■	■	■	■	■	■	■	■	■				
32	Brennerleitung 4300 2-Stufe	7 747 026 231	■	■	■	■	■	■	■	■	■	■	■	■				
33	Anschlussklemme 4-pol BR II Brenner weiß	7 747 023 980	■	■	■	■	■	■	■	■	■	■	■	■				
34	Steckerteil 4pol grün Ersatz	5181488	■	■	■	■	■	■	■	■	■	■	■	■				
35	Brennerleitung 700 f 2Stufen verlänger	5181048	■	■	■	■	■	■	■	■	■	■	■	■				nur für Brennerleitung 2. Stufe
36	Buchsenteil ST 18/4 mit Zugentlastung	7079432	■	■	■	■	■	■	■	■	■	■	■	■				nur für Brennerleitung 2. Stufe
37	Steckerteil 4pol grün Ersatz	5181488	■	■	■	■	■	■	■	■	■	■	■	■				
38	Mont-Mat S625/S725	5158700	■	■	■	■	■	■	■	■	■	■	■	■				
	Lacksprühdose RAL5013 400ml (UN1950)	5852100	■	■	■	■	■	■	■	■	■	■	■	■				Kobaltblau
	Kabeldurchführung geschl himmelblau	63045226	■	■	■	■	■	■	■	■	■	■	■	■				Kobaltblau
	Lacksprühdose RAL5015 150ml (himmelblau)	8 718 576 634 0	■	■	■	■	■	■	■	■	■	■	■	■				Buderus blau
SE625 / SE725									Verkleidung SE/SK 625/725 Casing SE/SK 625/725 Carénage SE/SK 625/725 Rivestimento SE/SK 625/725 Bekleding SE/SK 625/725 Revestimiento SE/SK 625/725							4		

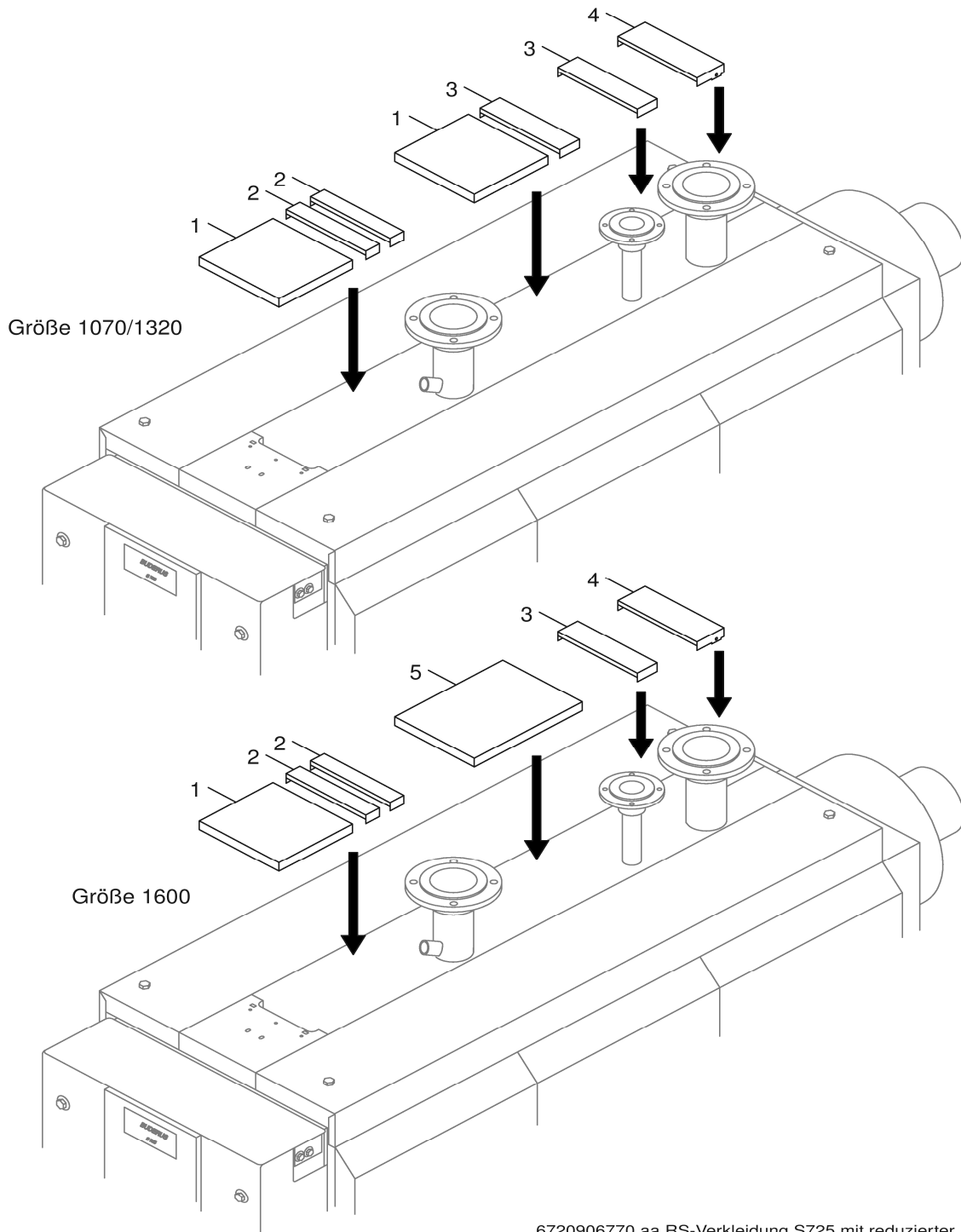

5

Verkleidung S725 S
Casing S725 S
Carénage S725 S
Rivestimento S725 S
Bekleding S725 S
Revestimiento S725 S

SE625 / SE725





Ersatzteilliste
Spare parts list

Liste des pièces de rechange
Lista parti di ricambio

Onderdelenlijst
Lista de repuestos

Hinweis!
Bei Bedarf von Pos. 15 für Verkleidungen
geliefert bis 30.04.1998 müssen Pos. 13+14
mitbestellt werden.

15 Notes for the user!
The position 13+14 must be ordered with,
when required by position 15 for casing
supplied till 30.04.1998

- 16
- 7x  ST3,9x9,5 A3T
 - 4x  ST4,8x19 A3K
 - 1x 
 - 1x 

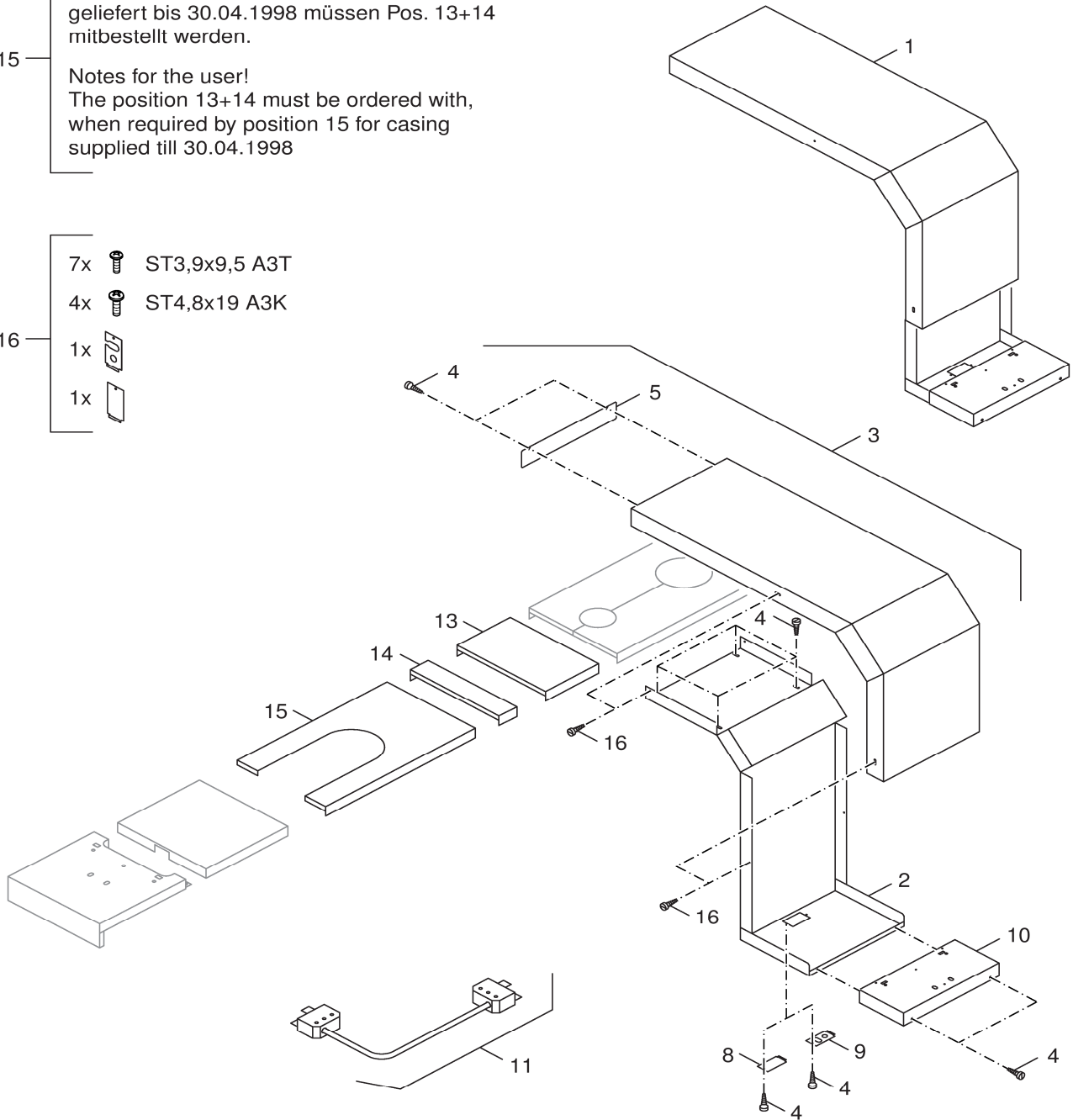

99902345.aa.RS-Träger für Regelgerät HS4311/4312/4212

6

Verkleidung Träger Regelgerät S625/725
casing fixing bracket control unit S625
Carénage Plaque de jonction S625/725
Rivestimento Supporto UnitÄ di comando
Bekleding Draaier Sturing S625/725
Revestimiento Soporte aparato de regulac

SE625 / SE725

Pos	Bezeichnung Description Dénomination Descrizioni Benaming Descripción	Bestell-Nr. Ordering no. Número de commande N° d'ordine Bestelnummer Número el ordenar	SE625-230	SE625-310	SE625-410	SE625-530	SE625-690	SE725-870	SE725-1070	SE725-1070 S	SE725-1320	SE725-1320 S	SE725-1600	SE725-1600 S				Bemerkungen Remarks Remarques Osservazioni Opmerkingen Observaciones
1	Träger f Regelgerät RAL 5015	5097580	■	■	■	■	■	■	■	■	■	■	■	■				
2	Träger für Regelgerät RAL 5015	7079670	■	■	■	■	■	■	■	■	■	■	■	■				
3	Abdeckung Träger für Regelgerät	63045232	■	■	■	■	■	■	■	■	■	■	■	■				
4	Flachkopfschraube ST3,9x9,5 A3T (10x)	7 747 026 999	■	■	■	■	■	■	■	■	■	■	■	■				
5	Deckblech Träger für Regelgerät	63045231	■	■	■	■	■	■	■	■	■	■	■	■				
8	Abdeckblech himmelblau	63045229	■	■	■	■	■	■	■	■	■	■	■	■				
9	Kabeldurchführung geschl himmelbl	63045226	■	■	■	■	■	■	■	■	■	■	■	■				
10	Haube HS 4311/4312	63045225	■	■	■	■	■	■	■	■	■	■	■	■				
11	Brennerleitung 8000 f 2-Stufe m Zugentl	7079690	■	■	■	■	■	■	■	■	■	■	■	■				
13	Haube hinten Teil B S625/S725	8 718 577 725 0						■	■	■	■	■	■	■				690-1600KW
14	Haube hinten Teil C S625/S725	8 718 577 724 0						■	■	■	■	■	■	■				690-1600KW
15	Haube hinten Teil A S625-690	5158562					■											
15	Haube hinten Teil A S725-870	5785530						■										
15	Haube hinten Teil A S725-1070/1370	5785532							■	■	■	■						
15	Haube hinten Teil A S725-1600	5785534											■	■				
16	Montagematerial Träger für Regelg	63045180	■	■	■	■	■	■	■	■	■	■	■	■				

SE625 / SE725

Verkleidung Träger Regelgerät S625/725
casing fixing bracket control unit S625
Carénage Plaque de jonction S625/725
Rivestimento Supporto UnitÃ di comando
Bekleding Draaier Sturing S625/725
Revestimiento Soporite aparato de regulac

6

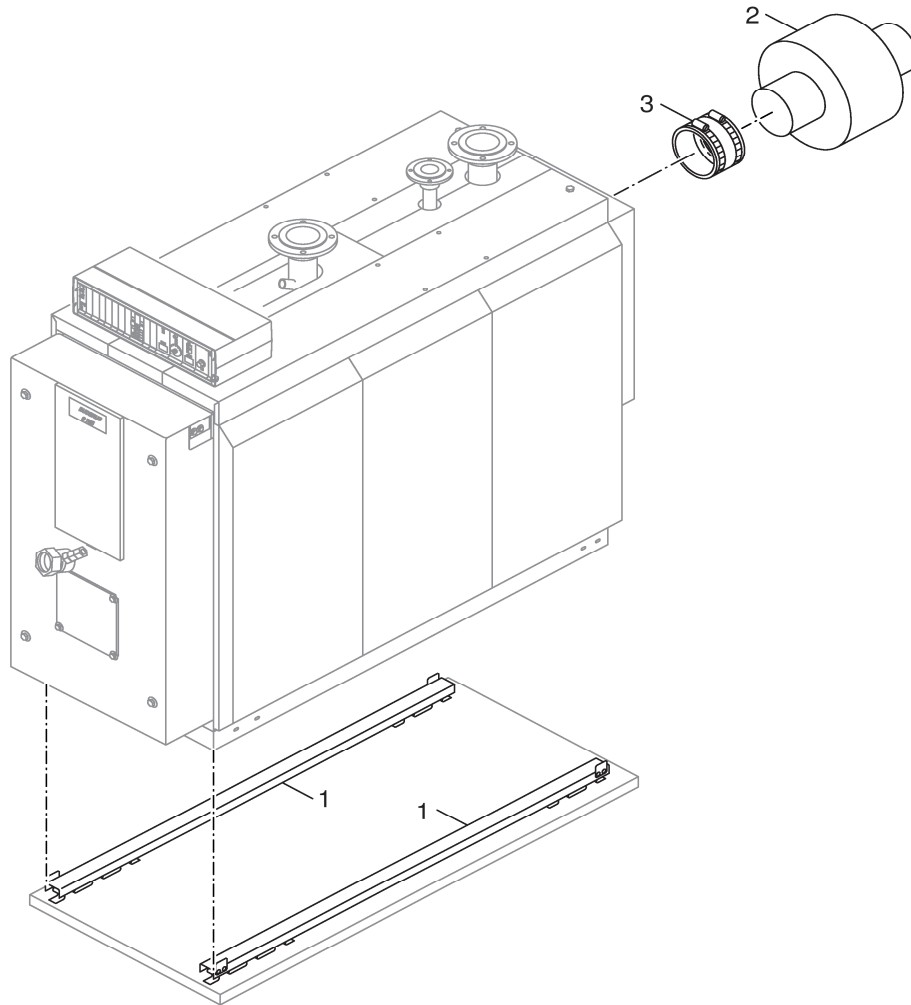

99907097.aa.RS-Schalldämmung SE/SK625/725

7

Schalldämmung SE/SK 625/725
sound absorption SE/SK 625/725
isolation acoustique SE/SK 625/725
isolamento acustico SE/SK 625/725
sound absorption SE/SK 625/725
la insonorización SE/SK 625/725

SE625 / SE725

Pos	Bezeichnung Description Dénomination Descrizioni Benaming Descripción	Bestell-Nr. Ordering no. Numéro de commande N° d'ordine Bestelnummer Número el ordenar	SE625-230	SE625-310	SE625-410	SE625-530	SE625-690	SE725-870	SE725-1070	SE725-1070 S	SE725-1320	SE725-1320 S	SE725-1600	SE725-1600 S				Bemerkungen Remarks Remarques Osservazioni Opmerkingen Observaciones
1	Kesselunterbau S625-230/310	5963850	■	■														230-310KW
1	Kesselunterbau S625-410/530	5963852			■	■												410-530KW
1	Kesselunterbau S625-690	5963854					■											690KW
1	Kesselunterbau S725-870, SK745-1200	5963860						■										690KW
1	Kesselunterbau S725-1070/1320 SK745-1400	5963862							■	■	■	■						690KW
1	Kesselunterbau S725-1600	5963864											■	■				690KW
2	Abgasschalldämpfer DN250 m Abdichtm kpl	5074550	■	■	■	■												230-530KW
2	Abgasschalldämpfer DN300 m Abdichtm kpl	5074552					■	■										690-870KW
2	Abgasschalldämpfer DN360 m Abdichtm kpl	5074554							■	■	■	■	■	■				690-870KW
3	Abgasrohrabdichtmansch DN250 kpl	5354038	■	■	■	■												230-530KW
3	Abgasrohrabdichtmansch DN300 kpl	5354040					■	■										690-870KW
3	Abgasrohrabdichtmansch DN360 kpl	5354042							■	■	■	■	■	■				690-870KW

SE625 / SE725

Schalldämmung SE/SK 625/725
 sound absorption SE/SK 625/725
 isolation acoustique SE/SK 625/725
 aislamiento acustico SE/SK 625/725
 sound absorption SE/SK 625/725
 la insonorización SE/SK 625/725

Ersatzteilliste
Spare parts list

Liste des pièces de rechange
Lista parti di ricambio

Onderdelenlijst
Lista de repuestos

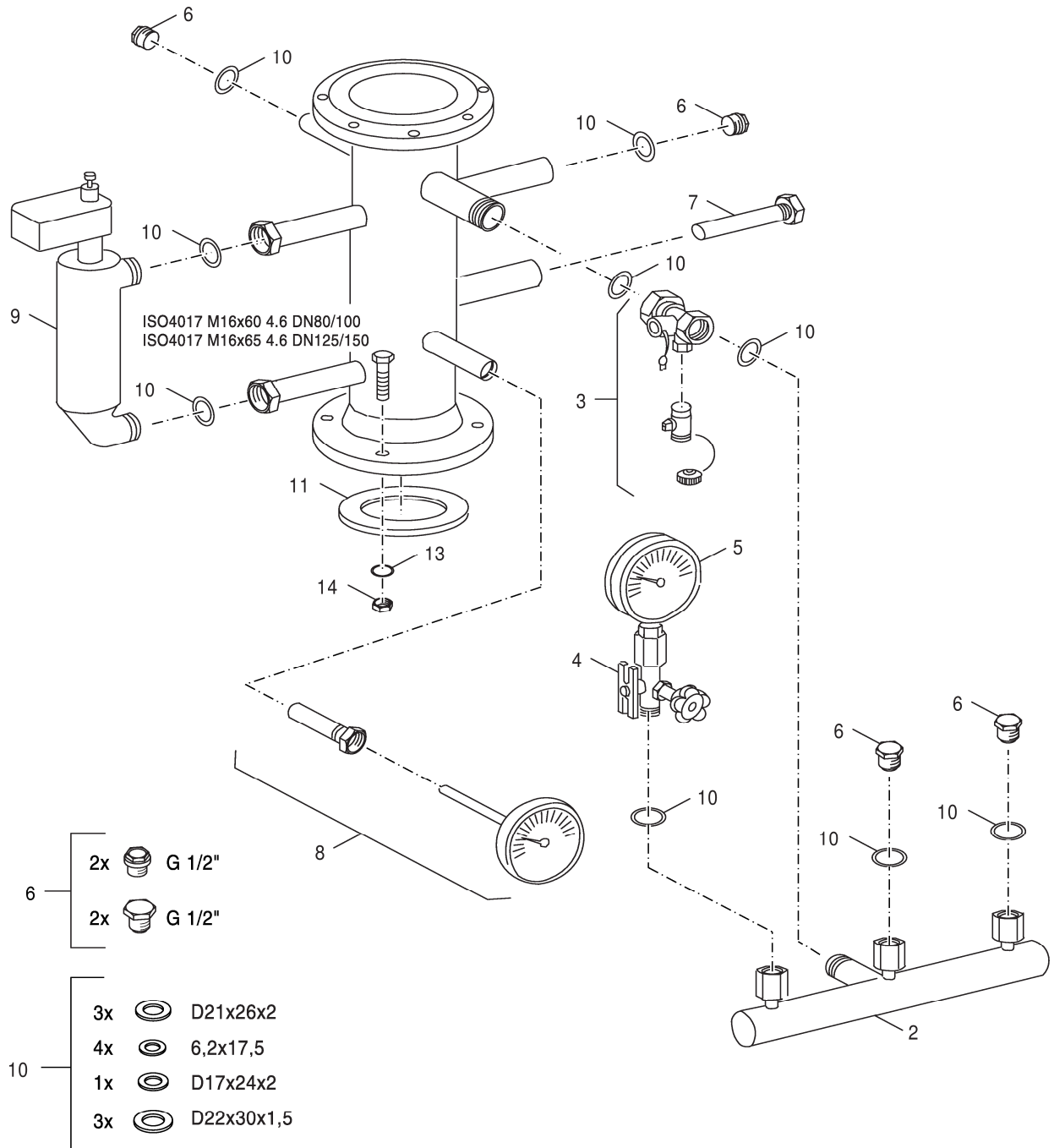

99902349.aa.RS-Sicherheitsarmaturengruppe SE/SK625/725

8

Kessel-Sicherheits-Armaturengr S625/725
Boiler safety valve set S625/725
Groupe de robinets de sécurité S625/725
Boiler safety valve set S625/725
Boiler safety valve set S625/725
Boiler safety valve set S625/725

SE625 / SE725

Ersatzteilliste
Spare parts list

Liste des pièces de rechange
Lista parti di ricambio

Onderdelenlijst
Lista de repuestos

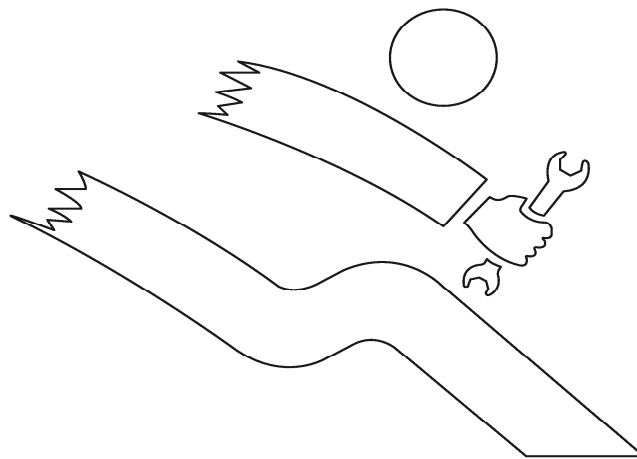

8738891230.aa.RS-Kundendienst

9

Kundendienst
Service department
Service après vente
Servizio clienti
Servicedienst
Servicio posventa

SE625 / SE725

Übersetzungsliste List of translations		Liste des traductions Traduzione delle descrizioni		Vertalinglijst Lista de traducciones	
Pos	Description	Denomination	Descrizione	Benaming	Descripción
1	Element of construction	Groupe de construction	Gruppo di costruzione	Montagegroep	Grupo de construcción
2	Packing cords 20x25x3120mm	JOINT PORTE 20X25X3120MM	Cordone di tenuta 20x25x3120mm	Afdichtkoord 20x25x3120mm	Cordon de junta 20x25x3120mm
2	Packing cords 20x25x3520mm	JOINT PORTE 20x25x3520mm	Cordone di tenuta 20x25x3520mm	Afdichtkoord 20x25x3520mm	Cordon de junta 20x25x3520mm
2	Packing cords 20x25x4050mm	JOINT PORTE 20x25x4050mm	Cordone di tenuta 20x25x4050mm	Afdichtkoord 20x25x4050mm	Cordon de junta 20x25x4050mm
2	Packing cords 20x25x5100mm long	Cordon d'étanchéité 20x25x5100mm	Cordone di tenuta 20x25x5100mm	Afdichtkoord 20x25x5100mm	Cordon de junta 20x25x5100mm
3	Sensor well R 3/4"x150mm long	Doigt de gant r3/4x150mm	Pozzetto ad immersione R 3/4"x150mm	Dompelhuls R 3/4x150 inw.19 mm	Vaina de inmersión R 3/4"x150mm long
4	Turbulator 1350/1710mm long SE625	Turbulateur 1350/1710 mm SE625	Turbolatore 1350/1710 mm SE625	Turbulator 1350/1710 mm SE625	Turbulador 1350/1710 mm SE625
4	Turbulator 1500/1890mm long SE625	Turbulateur longueur 1500/1890 mm SE625	Turbolatore 1500/1890 mm SE625	Turbulator 1500/1890 mm SE625	Turbulador 1500/1890 mm SE625
4	Turbulator 1350/1890mm long SE625	Turbulateur longueur 1350/1890 mm SE625	Turbolatore 1350/1890 mm SE625	Turbulator sk625-410/530/690	Turbulador 1350/1890 mm SE625
4	Turbulator 1650/1890mm long SE625	TURBULATEUR LONGEUR 1650/1890 mm SE625	Turbolatore 1650/1890 mm SE625	Turbulator 1650/1890 mm SE625	Turbulador 1650/1890 mm SE625
4	Turbulator 1650/2120mm long SE725	Turbulateur longueur 1650/2120 mm SE725	Turbolatore 1650/2120 mm SE725	Turbulator 1650/2120 mm SE725	Turbulador 1650/2120 mm SE725
4	Turbulator 1650/2240mm long SE725	Turbulateur longueur 1650/2240 mm SE725	Turbolatore 1650/2240 mm SE725	Turbulator 1650/2240 mm SE725	Turbulador 1650/2240 mm SE725
4	Turbulator 1650/2340mm long SE725	TURBULATEUR S725 LG 1650/2340mm	Turbolatore 1650/2340 mm SE725	Turbulator 1650/2340 mm SE725	Turbulador 1650/2340 mm SE725
5	Thermal insulation Part 2 S725 1070-1320	Isolation 2 S725 1070-1320KW	Isolamento 2 S725 1070-1320KW	Isolatie 2 S725 1070-1320KW	Aislante parte 2 S725-1070/1320kW
5	Thermal insulation Part 2 S625 230-310KW	Isolation 2 S625 230-310KW	Isolamento 2 S625 230-310KW	Isolatie 2 S625 230-310KW	Aislante parte 2 S625-230/310kW
5	Thermal insulation Part 2 S625 410-530KW	Isolation Part 2 S625 410-530KW	Isolamento 2 S625 410-530KW	Isolatie 2 S625 410-530KW	Aislante parte 2 S625-410/530kW
5	Thermal insulation Part 2 S625 690KW	Isolation 2 S625 690KW	Isolamento 2 S625 690KW	Isolatie 2 S625 690KW	Aislante parte 2 S625-690kW
5	Thermal insulation Part 2 S725 870KW	Isolation 2 S725 870KW	Isolamento 2 S725 870KW	Isolatie 2 S725 870KW	Aislante parte 2 S725-870kW
5	Thermal insulation Part 2 S725 1600KW	Isolation 2 S725 1600KW	Isolamento 2 S725 1600KW	Isolatie 2 S725 1600KW	Aislante parte 2 S725-1600kW
6	Insulation Clamp (10x)	Ressorts de retenue d 0.8 (10x)	Molla di tenuta (10x)	Borgveer (10x)	Muelle tensor para aislamientos (10x)
7	Thermal insulation Part 1 S625 690KW	Isolation 1 S625 690KW	Isolamento 1 S625 690KW	Isolatie 1 S625 690KW	Aislante parte 1 S625-690kW
7	Thermal insulation Part 1 S725 870KW	Isolation 1 S725 870KW	Isolamento 1 S725 870KW	Isolatie 1 S725 870KW	Aislante parte 1 S725-870kW
7	Thermal insulation Part 1 S725 1070-1320	Isolation 1 S725 1070-1320KW	Isolamento 1 S725 1070-1320KW	Isolatie 1 S725 1070-1320KW	Aislante parte 1 S725-1070/1320kW
7	Thermal insulation Part 1 S625 230-310KW	Isolation 1 S625 230-310KW	Isolamento 1 S625 230-310KW	Isolatie 1 S625 230-310KW	Aislante parte 1 S625-230/310kW
7	Thermal insulation Part 1 S625 410-530KW	Isolation 1 S625 410-530KW	Isolamento 1 S625 410-530KW	Isolatie 1 S625 410-530KW	Aislante parte 1 S625 410/530kW
7	Thermal insulation Part 1 S725 1600KW	Isolation 1 S725 1600KW	Isolamento 1 S725 1600KW	Isolatie 1 S725 1600KW	Aislante parte 1 S725-1600kW
8	Thermal insulation Part 5 S625 410-530KW	Isolation 5 S625 410-530KW	Isolamento 5 S625 410-530KW	Isolatie 5 S625 410-530KW	Aislante parte 5 S625-410/530kW
8	Thermal insulation Part 5 S625 690KW	Isolation 5 S625 690KW	Isolamento 5 S625 690KW	Isolatie 5 S625 690KW	Aislante parte 5 S625-690kW
8	Thermal insulation Part 5 S725 870KW	Isolation 5 S725 870KW	Isolamento 5 S725 870KW	Isolatie 5 S725 870KW	Aislante parte 5 S725-870kW
8	Thermal insulation Part 5 S725 1070-1320	Isolation 5 S725 1070-1320KW	Isolamento 5 S725 1070-1320KW	Isolatie 5 S725 1070-1320KW	Aislante parte 5 S725-1070/1320kW
8	Thermal insulation Part 5 S725 1600KW	Isolation 5 S725 1600KW	Isolamento 5 S725 1600KW	Isolatie 5 S725 1600KW	Aislante parte 5 S725-1600kW
8	Thermal insulation Part 5 S625 230-310KW	Isolation 5 S625 230-310KW	Isolamento 5 S625 230-310KW	Isolatie 5 S625 230-310KW	Aislante parte 5 S625-230/310kW
9	Thermal insulation Part 3 S625 690KW	Isolation 3 S625 690KW	Isolamento 3 S625 690KW	Isolatie 3 S625 690KW	Aislante parte 3 S625-690kW
9	Thermal insulation Part 3 S725 870KW	Isolation 3 S725 870KW	Isolamento 3 S725 870KW	Isolatie 3 S725 870KW	Aislante parte 3 S725-870kW
9	Thermal insulation Part 3 S725 1070-1320	Isolation 3 S725 1070-1320KW	Isolamento 3 S725 1070-1320KW	Isolatie 3 S725 1070-1320KW	Aislante parte 3 S725-1070/1320kW
9	Thermal insulation Part 3 S725 1600KW	Isolation 3 S725 1600KW	Isolamento 3 S725 1600KW	Isolatie 3 S725 1600KW	Aislante parte 3 S725-1600kW
9	Thermal insulation Part 3 S625 230-310KW	Isolation 3 S625 230-310KW	Isolamento 3 S625 230-310KW	Isolatie 3 S625 230-310KW	Aislante parte 3 S625-230/310kW
9	Thermal insulation Part 3 S625 410-530KW	Isolation 3 S625 410-530KW	Isolamento 3 S625 410-530KW	Isolatie 3 S625 410-530KW	Aislante parte 3 S625-410/530kW
10	Thermal insulation Part 4 S625 410-530KW	Isolation 4 S625 410-530KW	Isolamento 4 S625 410-530KW	Isolatie 4 S625 410-530KW	Aislante parte 4 S625-410/530kW
10	Thermal insulation Part 4 S625 690KW	Isolation 4 S625 690KW	Isolamento 4 S625 690KW	Isolatie 4 S625 690KW	Aislante parte 4 S625-690kW
10	Thermal insulation Part 4 S625 870KW	Isolation 4 S625 870KW	Isolamento 4 S625 870KW	Isolatie 4 S625 870KW	Aislante parte 4 S725-870kW
10	Thermal insulation Part 4 S625 1070-1320	Isolation 4 S625 1070-1320KW	Isolamento 4 S625 1070-1320KW	Isolatie 4 S625 1070-1320KW	Aislante parte 4 S725-1070/1320kW
10	Thermal insulation Part 4 S625 1600KW	Isolation 4 S625 1600KW	Isolamento 4 S625 1600KW	Isolatie 4 S625 1600KW	Aislante parte 4 S725-1600kW
10	Thermal insulation Part 4 S625 230-310KW	Isolation 4 S625 230-310KW	Isolamento 4 S625 230-310KW	Isolatie 4 S625 230-310KW	Aislante parte 4 S625-230/310kW
2	Element of construction	Groupe de construction	Gruppo di costruzione	Montagegroep	Grupo de construcción
3	G234X/334X M8 NUT FOR BASE	Ecrou 6 pans ISO4032 M8 8 A3K	Dado esagonale ISO4032 M8 8 A3K	Zeskantmoer ISO4032 M8 8 A3K	Tuerca hexagonal ISO4032 M8 8 A3K
4	Washer ISO 7089 A8,4 A3K (10x)	Rondelle plate ISO 7089 A8,4 A3K (10x)	Rondella ISO 7089 A8,4 A3K (10x)	Onderlegging ISO 7089 A8,4 A3K (10x)	Junta ISO 7089 A8,4 A3K (10x)
6	Clean-out cover D178mmm	Couvercle de trappe de ramonage D178mm	Coperchio di pulizia D178mmm	Reinigingsdeksel D178mmm	Tapa de limpieza D178mmm
7	Gasket D148x132x8mm GP	Joint D148x132x8mm GP	Guarnizione D148x132x8mm GP	Pakking D148x132x8mm GP	Junta D148x132x8mm GP
9	Flue gas header SE625 A 230kW	Buse de fumée compl. SE625 A 230kW	Collettore combust SE625 A 230kW	Rookgascollector SE625 A 230kW	Colector de gases SE625 A 230 kW
9	Flue gas header SE625 A 310kW	BOITE FUMEE SK 625 310KW	Collettore combust SE625 A 310kW	Rookgascollector SE625 A 310kW	Colector de gases SE625 A 310 kW
9	Flue gas header SE625 A 410kW	Buse de fumée compl. SE625 A 410kW	Collettore combust SE625 A 410kW	Rookgascollector SE625 A 410kW	Colector de gases SE625 A 410 kW
9	Flue gas header SE625 A 530kW	Buse de fumée compl. SE625 A 530kW	Collettore combust SE625 A 530kW	Rookgascollector SE625 A 530kW	Colector de gases SE625 A 530 kW
9	Flue gas header SE625 A 690kW	Buse de fumée compl. SE625 A 690kW	Collettore combust SE625 A 690kW	Rookgascollector SE625 A 690kW	Colector de gases SE625 A 690 kW
9	Flue gas header SE725 A 1070kW	Buse de fumée compl. SE725 A 1070kW	Collettore combust SE725 A 1070kW	Rookgascollector SE725 A 1070kW	Colector de gases SE725 A 1070 kW
9	Flue gas header SE725 A 1600kW	Buse de fumée compl. SE725 A 1600kW	Collettore combust SE725 A 1600kW	Rookgascollector SE725 A 1600kW	Colector de gases SE725 A 1600 kW
9	Flue gas header SE725 A 870kW	Buse de fumée compl. SE725 A 870kW	Collettore combust SE725 A 870kW	Rookgascollector SE725 A 870kW	Colector de gases SE725 A 870 kW

Übersetzungsliste List of translations		Liste des traductions Traduzione delle descrizioni		Vertalinglijst Lista de traducciones	
Pos	Description	Denomination	Descrizione	Benaming	Descripción
11	Packing cords 18x3300 GP	Joint etancheite gp 18x3300	Cordone ermetizzante 18x3300 GP	Afdichtingskoord 8x3300 GP	Cordón de junta 18 x 3300mm GP
12	Flue gas header SE625 A 230-310kW	Buse de fumée avant SE625 A 230-310kW	Collettore combust SE625 A 230-310kW	Rookgascollector SE625 A 230-310kW	Colector de gases SE625 A 230-310kW
12	Flue gas header SE625 A 410-530kW	Buse de fumée avant SE625 A 410-530kW	Collettore combust SE625 A 410-530kW	Rookgascollector SE625 A 410-530kW	Colector de gases SE625 A 410-530kW
12	Flue gas header SE625 A / SE725 A	Buse de fumée avant SE625 A / SE725 A	Collettore combust SE625 A / SE725 A	Rookgascollector SE625 A / SE725 A	Colector de gases SE625 A / SE725 A
12	Flue gas header SE725 A 1070-1320kW	Buse de fumée avant SE725 A 1070-1320kW	Collettore combust SE725 A 1070-1320kW	Rookgascollector SE725 A 1070-1320kW	Colector de gases SE725 A 1070-1320kW
12	Flue gas header SE725 A 1600kW	Buse de fumée avant SE725 A 1600kW	Collettore combust SE725 A 1600kW	Rookgascollector SE725 A 1600kW	Colector de gases SE725 A 1600 kW
13	Washer ISO 7089 10,5x2 (10x)	Rondelle plate ISO 7089 10,5x2 (10x)	Rondella ISO 7089 10,5x2 (10x)	Onderlegging ISO 7089 10,5x2 (10x)	Arandela ISO 7089 10,5x2 (10x)
14	Nut hex ISO4032 M10 8 A3K (4 pckd)	Écrou ISO4032 M10 8 A3K (4x)	Dado ISO4032 M10 8 A3K (4x)	Moer ISO4032 M10 8 A3K (4x)	Tuerca ISO4032 M10 8 A3K (4x)
3	Element of construction	Groupe de construction	Gruppo di costruzione	Montagegroep	Grupo de construcción
1	Burner door S625 230-310KW	Porte de br#leur S625 230-310KW	Porta del bruciatore S625 230-310KW	Branderdeur S625 230-310KW	Puerta quemador S625 230 310KW
1	Burner door S625 410-530KW	Porte de br#leur S625 410-530KW	Porta del bruciatore S625 410-530KW	Branderdeur S625 410-530KW	Puerta quemador S625 410-530KW
1	Burner door S625/S725 690-870KW	Porte de br#leur S625/S725 690-870KW	Porta del bruciatore S625/S725 690-870KW	Branderdeur S625/S725 690-870KW	Puerta quemador S625/S725 690-870KW
1	Burner door S725 1070-1320KW	Porte de br#leur S725 1070-1320KW	Porta del bruciatore S725 1070-1320KW	Branderdeur S725 1070-1320KW	Puerta quemador S725 1070-1320 kW
1	Burner door S725 1600KW	Porte de br#leur S725 1600KW	Porta del bruciatore S725 1600KW	Branderdeur S725 1600KW	Puerta quemador 1600KW S725
3	Clamp in screw joint GE 10-Ir Ermeto	VIS MALE DE CONNECTION GE 10-LR	Male_screw connection GE 10-Ir Ermeto	Kkoppeling met binnendraad	Racor para enroscar
8	Self-tapping screw DIN7516 A M5x10 A3K	ECROU DIN7516 A M5X10 A3K	Testa esagonale DIN7516 A M5x10 A3K	Self-tapping screw DIN7516 A M5x10 A3K	Tornillo de rosca corta DIN7516 A M5x10
9	Union nut B-Nr.4374 R 2"	Ecrou raccord B-Nr.4374 R 2"	Dado B-Nr.4374 R 2"	Wartelmoer B-Nr.4374 R 2"	Tuerca de racor B-Nr.4374 2
9	Union nut G1 1/2"x19 Ms packed	Écrou-raccord G1 1/2"x19 Ms	Controdado G1 1/2"x19 Ms	Wartelmoer G1 1/2"x19 Ms	Tuerca de racor G1 1/2"x19 Ms
10	Sealing ring DIN7603-a 50x57x2	JOINT VERRE VISEE CHAUD SK715 50X57	O-ring DIN7603-a 50x57x2	Afdichtring DIN7603-a 50x57x2	Junta plana DIN7603-a 50x57x2
10	Sealing ring 39x45x2mm	JOINT VERRE VISEE CHAUD SK615 39x45x2mm	Guarnizione 39x45x2mm	Afdichtring 39x45x2mm	Junta 39x45x2 mirilla SE / SK 625 / 725
11	Glass pane D55x5mm repl pack	Hublot D55x5mm	Vetrino D55x5mm	Kijkglas (los) omnimat/715	Mirilla D55x5mm
11	Glass pane 44 S=4,5-5,5 repl pack	Verre visee flamme chaud d44x4,5-5,5mm	Vetrino 44 S=4,5-5,5 (1x)	Kijkglas (los) s615/s625/s725	Mirilla 44 S=4,5-5,5 (1x)
12	Packing cords D30x3120mm	CORDON D'ETANCHEITE D30x3120mm	Cordone di tenuta D30x3120mm	Afdichtkoord D30x3120mm	Cordón de junta D30x3120mm
12	Packing cords D30x3720mm	CORDON ETANCHEITE 30x3720MM	Cordone di tenuta D30x3720mm	Afdichtkoord D30x3720mm	Cordón de junta D30x3720mm
12	Packing cords D30x4050mm	Cordon d'étanchéité D30x4050mm	Cordone di tenuta D30x4050mm	Dichtingskoord D30 x 4050mm Lang	Cordón de junta D30x4050mm
12	Packing cords D30x5100mm long	JOINT PORTE 30DX5100MM	Cordone di tenuta D30x5100mm	Afdichtkoord D30x5100mm	Cordón de junta D30x5100mm
13	Washer ISO 7089 A17 A3K (2x)	Rondelle ISO 7089 A17 A3K (2x)	Rondella ISO 7089 A17 A3K (2x)	Ring ISO 7089 A17 A3K (2x)	Arandela ISO 7089 A17 A3K (2x)
14	Screw DIN6921 M10x25 (10x)	Vis DIN6921 M10x25 (10x)	Vite DIN6921 M10x25 (10x)	Schroef DIN6921 M10x25 (10x)	Tornillo DIN6921 M10x25 (10x)
15	Hinge part left/rechts/top/bottom	Charn#re SE/SK 625-725	Cerniera SE/SK 625-725	Scharnier SE/SK 625-725	Bisagra SE/SK 625-725
16	Washer DIN7349 17 A3K (10x)	Rondelle plate DIN7349 17 A3K (10x)	Rondella DIN7349 17 A3K (10x)	Onderlegging DIN7349 17 A3K (10x)	Arandela DIN7349 17 A3K (10x)
17	Hex bolt ISO4014 M16x280mm 8.8	Vis 6 pans ISO4014 M16x280mm 8.8	Vite testa esagonale ISO4014 M16x280mm	Schroef ISO4014 M16x280mm 8.8	Tornillo de cabeza hexagonal M16x280mm
17	Hex bolt ISO4014 M16x380mm 8.8	Vis 6 pans ISO4014-M16x380-8.8	Vite testa esagonale ISO4014 M16x380mm 8	Schroef ISO4014 M16x380mm 8.8	Tornillo de cabeza hexagonal M16x380mm
17	Hex bolt ISO4014 M16x320 8.8	Vis 6 pans ISO4014 M16x320 8.8	Vite testa esagonale ISO4014 M16x320mm 8	Schroef ISO4014 M16x320mm 8.8	Tornillo de cabeza hexagonal M16x320mm
18	Gasket burner plate S725 size 1070-1600	Joint plaque br#leur S725 1070-1600KW	Guarnizione Piastra bruciatore 1070-1600	Pakking Branderplaat S725 1070-1600KW	Junta Placa del quemador S725 1070-1600
18	Gasket burner plate S625 size 230-310kW	Joint plaque br#leur S625 230-310KW	Guarnizione Piastra bruciatore 230-310KW	Pakking Branderplaat S625 230-310KW	Junta Placa del quemador S625 230-310KW
18	Gasket Burner plate 338x338x8mm	Joint plaque br#leur 338x338x8mm	Guarnizione Piastra bruciatore 338x338x8	Pakking branderplaat 338x338x8mm	Junta Placa de Quemador 338x338x8mm
19	Blank burner plate 10x338x338mm	Plaque br#leur 10x338x338mm	Piastra bruciat. cieca 10x338x338mm	Blind Branderplaat 10x338x338mm	Junta quemador ciega 10x338x338mm
19	Burner plate standard 430x430x10mm	PLAQUE BRULEUR CHAUD SE 625 /SK 725	Piastra bruciatore 430x430x10mm	Branderplaat 430mm sk/se	Placa del quemador 430x430x10mm
19	Blank burner plate 10x298x298mm	Plaque br#leur 10x298x298mm	Piastra bruciatore cieca 10x298x298mm	Branderplaat 10x298x298mm	Placa quemador ciega 10x298x298mm
21	Screw Hexagon-head ISO4017 M12x45 (10x)	Vis # t#te hexagonale M12x45 (10x)	Vite ISO4017 M12x45 (10x)	Schroef ISO4017 M12x45 (10x)	Tornillo de cabeza hexagonal ISO4017
22	Disc ISO 7089-A13-A3K (5x)	Rondelle ISO 7089-A13-A3K (5x)	Rondella ISO 7089-A13-A3K (5x)	Ring ISO 7089-A13-A3K (5x)	Arandela ISO 7089-A13-A3K (5x)
23	Insulating ring burner door S625	Bague d'isolation Porte de br#leur S625	Isolamento anulare Porta del bruciatore	Isolatie ring Branderdeur S625 230-310kW	Anillo de aislamiento puerta quemador
23	Insulating ring burner door S625/S725	Bague d'isolation Porte de br#leur	Isolamento anulare Porta del bruciatore	Isolatie ring Branderdeur S625-S725/690-1600	Anillo de aislamiento puerta quemador
	Repair substance Calde Stix14 G3, 25kg	Masse de réparation Calde Stix14 G3,25kg	Reparaturmasse Calde Stix14 G3, 25kg	Reparaturmasse Calde Stix14 G3, 25kg	Sustancia reparadora plístix 14, 25kg
	Aerosol paint RAL5015 150ml (sky blue)	PEINTURE BOMBE RAL 5015 150 ML BLEU CIEL	Bombola spray RAL5015 150ml (azzurro)	Sputibus RAL5015 150ml (hemelsblauw)	Bote de spray RAL5015 150ml azul celeste
	Filler Fibrefrax 140 pumpable 300ml	Masse de réparation Fibrefrax 140 - 300m	Reparaturmasse Fibrefrax 140 - 300ml	Reparaturmasse Fibrefrax 140 - 300ml	Sustancia reparadora Fibrefrax 140 - 300
4	Element of construction	Groupe de construction	Gruppo di costruzione	Montagegroep	Grupo de construcción
1	Cover bottom right/left S625 230-310KW	SOCLE BAS S625/230-310KW	Mascherina/Pannello sotto S625 230-310	Afdekplaat Onder S625 230-310KW	Diafragma debajo S625 230-310KW
1	Cover bottom right/left S625 410-690KW	SOCLE BAS S625/410-690	Mascherina/Pannello sotto S625 410-690	Afschermstrip onder mantel S625/530	Diafragma debajo S625 410-690KW
1	Cover bottom right/left S725 870KW	SOCLE BAS S725 870KW	Mascherina/Pannello sotto S725 870KW	Afdekplaat Onder S725 870KW	Diafragma debajo S725 870KW
1	Cover bottom right/left S725 1070-1320KW	SOCLE BAS S725 1070-1320KW	Mascherina/Pannello sotto S725 1070-132	Afdekplaat Onder S725 1070-1320KW	Diafragma debajo S725 1070-1320KW
1	Cover bottom right/left S725 1600KW	SOCLE BAS S725 1600KW	Mascherina/Pannello sotto S725 1600KW	Afdekplaat Onder S725 1600KW	Diafragma debajo S725 1600KW
2	Screw M8x16 (4x)	Vis M8x16 (4x)	Vite M8x16 (4x)	Schroef M8x16 (4x)	Tornillo M8x16 (4x)
3	Washer ISO 7089 A8,4 A3K (10x)	Rondelle plate ISO 7089 A8,4 A3K (10x)	Rondella ISO 7089 A8,4 A3K (10x)	Onderlegging ISO 7089 A8,4 A3K (10x)	Junta ISO 7089 A8,4 A3K (10x)
4	Tie-bar bottom front/rear S625 230-310kW	Traverse inférieure avant et arrière S625	Traversa sotto S625 230-310kW	Vangschaal Onder S625 230-310kW	Perfil inferior delantero/trasero
4	Tie-bar bottom front/rear S625 410-530kW	Traverse inférieure avant et arrière S625	Traversa sotto S625 410-530kW	Vangschaal Onder S625 410-530kW	Perfil inferior delantero/trasero S625
4	Tie-bar bottom front/rear S625/S725	Traverse inférieure avant et arrière	Traversa sotto S625/S725 690-870KW	Vangschaal Onder S625/S725 690-870KW	Perfil inferior delantero/trasero

Übersetzungsliste List of translations		Liste des traductions Traduzione delle descrizioni		Vertalinglijst Lista de traducciones	
Pos	Description	Denomination	Descrizione	Benaming	Descripción
4	Tie-bar bottom front/rear S725 V2	TRAVERSE DESSOUS AVANT/ARRIERE S725	Traversa sotto S725 V2 1070-1320kW	Vangschaal Onder S725 V2 1070-1320kW	Perfil inferior delantero/trasero S725
4	Tie-bar bottom front/rear S725 V2 1600	Traverse dessous avant et arri#re S725V2	Traversa sotto S725 V2 1600kW	Vangschaal Onder S725 V2 1600kW	Perfil inferior delantero/trasero S725
5	G234X/334X M8 NUT FOR BASE	Ecrou 6 pans ISO4032 M8 8 A3K	Dado esagonale ISO4032 M8 8 A3K	Zeskantmoer ISO4032 M8 8 A3K	Tuerca hexagonal ISO4032 M8 8 A3K
6	Pan-head screw ST3,9x9,5 A3T (10x)	Vis # #tte plate ST3,9 (10x)	Vite a testa piana ST3,9x9,5 (10x)	Schroef met vlakke kop ST3,9x9,5 (10x)	Tornillo avellanado ST3,9x9,5 (10x)
7	Tie-bar top front/rear S625 230-310KW	Traverse supérieur avant et arri#re	Traversa sopra S625 230-310KW	Vangschaal Boven S625 230-310KW	Perfil superior delantero/trasero
7	Tie-bar top front/rear S625 410-530KW	Traverse supérieur avant et arri#re	Traversa sopra S625 410- 530KW	Vangschaal Boven S625 410- 530KW	Perfil superior delantero/trasero S625
7	Tie-bar top front/rear S625/S725	Traverse supérieur avant et arri#re	Traversa sopra S625/S725 690-870KW	Vangschaal Boven S625/S725 690-870KW	Perfil superior delantero/trasero
7	Tie-bar top front/rear S725 1070-1320KW	Traverse supérieur avant et arri#re S725	Traversa sopra S725 1070-1320KW	Vangschaal Boven S725 1070-1320KW	Perfil superior delantero/trasero S725
7	Tie-bar top front/rear S725 1600KW	Traverse avant et arri#re S725 1600KW	Traversa sopra S725 1600KW	Vangschaal Boven S725 1600KW	Perfil superior delantero/trasero S725
8	Cable clip (5x)	ATTACHE RAPIDE (5x)	Angolare (5x)	Kabelhouder (5x)	Sujetacable (5x)
9	Side panel right/left S625 230-310kW	Paroi latérale droite gauche S625	Parete laterale destra sinistra S625	Zijwand Rechts Links S625 230-310kW	Carcasa lateral izquierda S625-230/310
9	Side panel right/left S625 410-530kW	Paroi latérale droite gauche S625 410-530	Parete laterale destra sinistra S625	Zijwand Rechts Links S625 410-530kW	Carcasa lateral izquierda S625 410-530kW
9	Side panel left S625/S725 690-870kW	Paroi latérale droite gauche S625/S725	Parete laterale destra sinistra S625/S725	Zijwand Rechts Links S625/S725 690-870kW	Carcasa lateral izquierda S625/S725
9	Side panel left S725 1070-1320kW	Paroi latérale droite gauche S725	Parete laterale destra sinistra S725	Zijwand Rechts Links S725 1070-1320kW	Carcasa lateral izquierda S725 1070-1320
9	Side panel left S725 1600kW	Paroi latérale droite gauche S725 1600kW	Parete laterale destra sinistra S725	Zijwand Rechts Links S725 1600kW	Carcasa lateral izquierda S725 1600kW
10	Side panel middle S625 410-530KW	HABIL LAT INTERM S625 410-530KW	Parete laterale intermedio S625 410-530	Zijwand midden S625 410-530KW	Carcasa lateral central S625 410-530KW
10	Side panel middle S625 690KW	Panneau latéral interm. S625 690KW	Parete laterale intermedio S625 690KW	Zijwand midden S625 690KW	Carcasa lateral central S625-690
10	Side panel middle S725 870KW	Panneau lat.intérmed. S725 870KW	Parete laterale intermedio S725 870KW	Zijwand midden S725 870KW	Carcasa lateral central S725 870KW
10	Side panel middle S725 1070-1320KW	Panneau lat.intérmed. S725 1070-1320KW	Parete laterale intermedio S725 1070-1320	Zijwand midden S725 1070-1320KW	Carcasa lateral central S725 1070-1320KW
10	Side panel middle S725 1600KW	Panneau lat.intérmed. S725 1600KW	Parete laterale intermedio S725 1600KW	Zijwand midden S725 1600KW	Carcasa lateral central S725 1600KW
11	Side panel right/left S625 230-310kW	Panneau lat. avant droit/arri#re gauche	Parete laterale destra sinistra S625	Zijwand Rechts Links S625 230-310kW	Carcasa lateral derecha S625-230/310
11	Side panel right S625 410-530kW	Panneau lat. avant droit/arri#re gauche	Parete laterale destra sinistra S625	Zijwand Rechts Links S625 410-530kW	Carcasa lateral derecha S625 410-530kW
11	Side panel right S625/S725 690-870kW	Panneau lat. avant droit/arri#re gauche	Parete laterale destra sinistra S625/S725	Zijwand Rechts Links S625/S725 690-870kW	Carcasa lateral derecha S625/S725
11	Side panel right/left S725 1070-1320kW	Panneau lat. avant droit/arri#re gauche	Parete laterale destra sinistra S725	Zijwand Rechts Links S725 1070-1320kW	Carcasa lateral derecha S725 1070-1320kW
11	Side panel right S725 1600kW	Panneau lat. avant droit/arri#re gauche	Parete laterale destra sinistra S725 1600	Zijwand Rechts Links S725 1600kW	Carcasa lateral derecha S725 1600kW
12	Rear panel bottom S625 230-310KW	Panneau arri#re inférieur S625 230-310	Parete posteriore sotto S625 230-310KW	Achterwand Onder S625 230-310KW	Carcasa trasera inferior S625-230/310
12	Rear panel bottom S625 410-530KW	Panneau arri#re inférieur S625 410-530KW	Parete posteriore sotto S625 410-530KW	Achterwand Onder S625 410-530KW	Carcasa trasera inferior S625 410-530KW
12	Rear panel bottom S625/S725 690-870KW	Panneau arri#re inférieur S625/S725	Parete posteriore sotto S625/S725	Achterwand Onder S625/S725 690-870KW	Carcasa trasera inferior S625/S725
12	Rear panel bottom S725 1070-1320KW	Panneau arri#re inférieur S725 1070-1320	Parete posteriore sotto S725 1070-1320KW	Achterwand Onder S725 1070-1320KW	Carcasa trasera S725-1070/1320 complete
12	Rear panel bottom S725 1600KW	Panneau arri#re inférieur S725 1600KW	Parete posteriore sotto S725 1600KW	Achterwand Onder S725 1600KW	Carcasa trasera inferior S725 1600KW
13	Rear panel top right S625 230-310KW	Panneau arri#re supérieur droit S625	Parete posteriore sopra destra S625	Achterwand Boven Rechts S625 230-310KW	Carcasa trasera superior derecho S625
13	Rear panel top right S625 410- 530KW	Panneau arri#re supérieur droit S625	Parete posteriore sopra destra S625	Achterwand Boven Rechts S625 410- 530KW	Carcasa trasera superior derecho S625
13	Rear panel top right S625/S725 690-870KW	Panneau arri#re supérieur droit S625	Parete posteriore sopra destra S625	Achterwand Boven Rechts S625 690-870KW	Carcasa trasera superior derecho S625
13	Rear panel top right S725 1070-1320KW	Panneau supérieur droit S625	Parete posteriore sopra destra S625	Achterwand Boven Rechts S625 1070-1320KW	Carcasa trasera superior derecho S625
13	Rear panel top right S725 1600KW	Panneau supérieur droit S725 1600KW	Parete posteriore sopra destra S725 1600	Achterwand Boven Rechts S725 1600KW	Carcasa trasera superior derecho S725
14	Nut 3,9-A3K_SNU5743 packed	Écrou	Dado	Moer	tuerca
15	Rear panel top left S625 230-310KW	HABIL ARR HAUT GAUCHE S625 230-310KW	Parete posteriore sopra sinistra S625	Achterwand Boven Links S625 230-310KW	Carcasa trasera-superior izquierda S625
15	Rear panel top left S625 410-530KW	HABIL ARR HAUT GAUCHE S625 410-530KW	Parete posteriore sopra sinistra S625	Achterwand Boven Links S625 230-310KW	Carcasa trasera-superior izquierda S625
15	Rear panel top left S625/S725 690-870KW	HABIL ARR HAUT GAUCHE S625/960 S725/870	Parete posteriore sopra sinistra	Achterwand Boven Links S625/S725 690-870	Carcasa trasera-superior izquierda
15	Rear panel top left S725 1070-1320KW	HABIL ARR HAUT GAUCHE S725 1070-1320KW	Parete posteriore sopra sinistra S725	Achterwand Boven Links S725 1070-1320KW	Carcasa trasera-superior izquierda S725
15	Rear panel top left S725 1600KW	HABIL ARR HAUT GAUCHE S725 1600KW	Parete posteriore sopra sinistra S725	Achterwand Boven Links S725 1600KW	Carcasa trasera-superior izquierda S725
16	Connection tongue 80x30x0,75mm	Barreau de jonction 80x30x0,75mm	Linguetta 80x30x0,75mm	Verbindingsclip achterpanelen S625/530	Pletina unión 80x30x0,75mm
17	Facing panel right S625 230-310KW	Tôle de protection droit S625 230-310KW	Lamiera di protezione destra S625	Afdekplaat Rechts S625 230-310KW	Chapa de recubrimiento dcha S625
17	Facing panel right S625 410- 530KW	Tôle de protection droit S625 410- 530KW	Lamiera di protezione destra S625 690kW	Afdekplaat Rechts S625 410- 530KW	Chapa de recubrimiento dcha S625 410-
17	Facing panel right S625 690kW	Tôle de protection droit S625 690kW	Lamiera di protezione destra S625 690kW	Afdekplaat Rechts S625 690kW	Chapa de recubrimiento dcha S625 690kW
17	Facing panel right S725 870kW	Tôle de protection droit S725 870kW	Lamiera di protezione destra S725 870kW	Afdekplaat Rechts S725 870kW	Chapa de recubrimiento dcha S725 870kW
17	Facing panel right S725 1070-1320kW	Tôle de protection droit S725 1070-1320	Lamiera di protezione destra S725	Afdekplaat Rechts S725-1070-1320kW	Chapa de recubrimiento dcha S725
17	Facing panel right S725 1600kW	Tôle de protection droit S725 1600kW	Lamiera di protezione destra S725 1600kW	Afdekplaat Rechts S725 1600kW	Chapa de recubrimiento dcha S725 1600kW
18	Hood front S625 230-530KW	Dessus avant S625 230-530KW	Coperchio anteriore S625 230-530KW	Afdekkap Voor S625 230-530KW	Carcasa superior delantera SE/SK625/725
18	Hood front S625/S725 690-1600KW	Dessus avant S625/S725 690-1600KW	Coperchio anteriore S625/S725 690-1600KW	Afdekkap Voor S625/S725 690-1600KW	Carcasa superior delantera SE/SK625/725
19	Hood middle S625 230-690kW	Capot milieu S625 230-690kW	Coperchio intermedio S625 230-690kW	Afdekkap midden S625 230-690kW	Carcasa superior central S625 230-690kW
19	Hood middle S725 870-1600kW	Capot milieu S725 870-1600kW	Coperchio intermedio S725 870-1600kW	Afdekkap midden S725 870-1600kW	Carcasa superior central S725 870-1600kW
20	Hood rear S625 230- 310kW	Dessus arri#re S625 230- 310kW	Coperchio posteriore S625 230- 310kW	Afdekkap Achter S625 230- 310kW	Carcasa media trasera S625-230/310
20	Hood rear S625 410-530kW	Dessus arri#re 410-530kW	Coperchio posteriore S625 410-530kW	Afdekkap Achter S625 410-530kW	Carcasa media trasera S625-410/530
21	Facing panel left S625 230-310KW	Tôle de protection gauche S625 230-310KW	Lamiera di protezione sinistra S625	Afdekplaat Links S625 230-310KW	Chapa de recubrimiento izqda S625
21	Facing panel left S625 410-530KW	Tôle de protection gauche S625 410-530KW	Lamiera di protezione sinistra S625	Afdekplaat Links S625 410-530KW	Chapa de recubrimiento izqda S625
21	Facing panel left S625 690kW	Tôle de protection gauche S625 690kW	Lamiera di protezione sinistra S625	Afdekplaat Links S625 690kW	Chapa de recubrimiento izqda S625 690kW

Übersetzungsliste List of translations		Liste des traductions Traduzione delle descrizioni		Vertalinglijst Lista de traducciones	
Pos	Description	Denomination	Descrizione	Benaming	Descripción
21	Facing panel left S725 870kW	Tôle de protection gauche S725 870kW	Lamiera di protezione sinistra S725	Afdekplaat Links S725 870KW	Chapa de recubrimiento izqda S725 870KW
21	Facing panel left S725 1070-1320kW	HABIL DESSUS GAUCHE S725/1070-1320	Lamiera di protezione sinistra S725	Afdekplaat Links S725 1070-1320KW	Chapa de recubrimiento izqda S725
21	Facing panel left S725 1600kW	Tôle de protection gauche S725 1600kW	Lamiera di protezione sinistra S725	Afdekplaat Links S725 1600KW	Chapa de recubrimiento izqda S725 1600KW
22	Hood rear left S625/S725 690-870kW	Dessus arri#re gauche S625/S725	Coperchio posteriore sinistra S625/S725	Afdekkap Achter Links S625/S725	Carcasa superior trasera izq.
22	Hood rear left S625 210-530kW	Dessus arri#re gauche S625 210-530kW	Coperchio posteriore sinistra S625	Afdekkap Achter Links S625 210-530KW	Carcasa superior trasera izq.
22	Hood rear left S725 1070-1320kW	Dessus arri#re gauche S725 1070-1320kW	Coperchio posteriore sinistra S725	Afdekkap Achter Links S725 1070-1320KW	Carcasa superior trasera izq.
22	Hood rear left S725 1600kW	Dessus arri#re gauche S725 1600kW	Coperchio posteriore sinistra S725 1600k	Afdekkap Achter Links S725 1600KW	Carcasa superior trasera izq.
23	Hood rear right S625 690kW	Dessus arri#re droit S625 690kW	Coperchio posteriore destra S625 690kW	Afdekkap Achter Rechts S625 690KW	Carcasa superior trasera dch.
23	Hood rear right S625 210-530kW	Dessus arri#re droit S625 210-530kW	Coperchio posteriore destra S625 210-530	Afdekkap Achter Rechts S625 210-530KW	Carcasa superior trasera dch.
23	Hood rear right S725 1070-1320kW	Dessus arri#re droit S725 1070-1320kW	Coperchio posteriore destra S725 1070-13	Afdekkap Achter Rechts S725 1070-1320KW	Carcasa superior trasera dch.
23	Hood rear right S725 1600kW	Dessus arri#re droit S725 1600kW	Coperchio posteriore destra S725 1600kW	Afdekkap Achter Rechts S725 1600KW	Carcasa superior trasera dch.
24	Covers burner door S625 210-480kW	Cache pte br#l.avant (livré jusqu'au	Pannello Porta del bruciatore S625 210-	Afdekplaat Branderdeur S625 210-480KW	Recubrimiento puerta del quemador S625
24	Cover burner door S625/S725 600-750kW	Cache pte br#l.avant (livré jusqu'au	Pannello Porta del bruciatore S625/S725	Afdekplaat Branderdeur S625/S725 600-750	Recubrimiento puerta del quemador
24	Covers burner door S625 230-530kW	Cache pte b#leur avant S625 230-530kW	Pannello Porta del bruciatore S625	Afdekplaat Branderdeur S625 230-530KW	Recubrimiento puerta del quemador S625
24	Cover burner door S625/S725 690-870kW	Cache pte br#leur avant S625/S725	Pannello Porta del bruciatore S625/S725	Afdekplaat Branderdeur S625/S725 690-870	Recubrimiento puerta del quemador
24	Cover burner door S725 1070-1320kW	Cache pte b#leur avant S725 1070-1320kW	Pannello Porta del bruciatore S725	Afdekplaat Branderdeur S725 1070-1320KW	Recubrimiento puerta del quemador S725
24	Cover burner door S725 1600kW	Cache pte br#l.avant S725 1600kW	Pannello Porta del bruciatore S725 1600	Afdekplaat Branderdeur S725 1600KW	Recubrimiento puerta del quemador S725
24	Cover burner door S725 920-1150kW	Cache pte br#l.avant (livré jusqu'au	Pannello Porta del bruciatore S725	Afdekplaat Branderdeur S725 920-1150KW	Recubrimiento puerta del quemador S725
24	Cover burner door S725 1350kW	Cache pte br#l.avant (livré jusqu'au	Pannello Porta del bruciatore S725 1350	Afdekplaat Branderdeur S725 1350KW	Recubrimiento puerta del quemador S725
25	Badge Logano SE625	Plaque signalétique Logano SE625	Targhetta caldaia Logano SE625	Toestelplaat Logano SE625	Placa Logotipo S 625-230
25	Badge Logano SE725	Plaque signalétique Logano SE725	Targhetta caldaia Logano SE725	Toestelplaat Logano SE725	Placa Logotipo Logano SE725
25	Badge Logano plus SE625	Plaque signalétique Logano Plus SE625	Targhetta caldaia Logano Plus SE625	Toestelplaat Logano Plus SE625	Placa Logotipo Logano Plus SE625
25	Badge Logano plus SE725	Plaque signalétique Logano Plus SE725	Targhetta caldaia Logano Plus SE725	Toestelplaat Logano Plus SE725	Placa Logotipo Logano Plus SE725
26	Cover top S625/S725 600-750kW	Cache pte br#l.supérieur (livré jusqu'au	Pannello sopra S625/S725 600-750kW	Afdekplaat Boven S625/S725 600-750KW	Recubrimiento superior S625/S725
26	Cover top S625 210-480kW	Cache pte br#l.supérieur (livré jusqu'au	Pannello sopra S625 210-480kW	Afdekplaat Boven S625 210-480KW	Recubrimiento superior S625 210-480KW
26	Cover top S725 920-1350kW	Cache pte br#l.supérieur (livré jusqu'au	Pannello sopra S725 920-1350kW	Afdekplaat Boven S725 920-1350KW	Recubrimiento superior S725 920-1350KW
27	Cover front S625 230-310kW	Cache avant S625 230-310kW	Pannello anteriore S625 230-310kW	Afdekplaat Voor S625 230-310KW	Bastidor delantero S 625-230/310
27	Cover front S625 410-530kW	Cache avant S625 410-530kW	Pannello anteriore S625 410-530kW	Afdekplaat Voor S625 410-530KW	Bastidor delantero S625 410-530KW
27	Conver front S625 690kW	Cache avant S625 690kW	Pannello anteriore S625 690kW	Afdekplaat Voor S625 690KW	Bastidor delantero S625 690KW
27	Cover front S725 870kW	Cache avant S725 870kW	Pannello anteriore S725 870kW	Afdekplaat Voor S725 870KW	Bastidor delantero S725 870KW
27	Cover front S725 1070-1320kW	Cache avant S725 1070-1320kW	Pannello anteriore S725 1070-1320kW	Afdekplaat Voor S725 1070-1320KW	Bastidor delantero S725 1070-1320KW
27	Cover front S725 1600kW	Cache avant S725 1600kW	Pannello anteriore S725 1600kW	Afdekplaat Voor S725 1600KW	Bastidor delantero S725 1600KW
28	Cover rear S625 230-310kW	Cache arri#re S625 230-310kW	Pannello posteriore S625 230-310kW	Afdekplaat achter S625 230-310KW	Bastidor trasero S625-230/310
28	Cover rear S625 410-530kW	Cache arri#re S625 410-530kW	Pannello posteriore S625 410-530kW	Afdekplaat achter S625 410-530KW	Bastidor trasero S625 410-530KW
28	Cover rear S625 690kW	Cache arri#re S625 690kW	Pannello posteriore S625 690kW	Afdekplaat achter S625 690KW	Bastidor trasero S625 690KW
28	Cover rear S725 870kW	Cache arri#re S725 870kW	Pannello posteriore S725 870kW	Afdekplaat achter S725 870KW	Bastidor trasero S725 870KW
28	Cover rear S725 1070-1320kW	Cache arri#re S725 1070-1320kW	Pannello posteriore S725 1070-1320kW	Afdekplaat achter S725 1070-1320KW	Bastidor trasero S725 1070-1320KW
28	Cover rear S725 1600kW	Cache arri#re S725 1600kW	Pannello posteriore S725 1600kW	Afdekplaat achter S725 1600KW	Bastidor trasero S725 1600KW
29	Burner connecting cable 5000mm long	Câble de raccord. 5000mm	Linea del bruciatore 5000mm	Branderleiding 5000mm	Cable Quemador 5000mm con conector
29	Burner cable 8000mm long	Cable brul 1 allure 8000mm	Linea del bruciatore 8000mm	Branderkabel 8000mm S625/725/735	Cable del quemador 8000mm
30	Connector 7-pole BR I green	Borne de connexion 7- pôles BR I vert	Morsetto collegamento bruciatore 7-poli	Afsluitklem 7- polig BR I groen	Borne de conexión 7- polos BR I verde
31	Connector part ST18/7 silver-plated	Connect st18/7 argente	Connessione a spina ST18/7 argentata	Stekker "M" 7-polig (Eurofiche)	Clavija ST18/7 plateada
32	Burner cable 4300mm 2-step	Câble bruleur 2 allu/ou modulant	Linea del bruciatore 4300mm+Fermo antir.	Branderleiding 4300mm + Trekontlasting	Cable del quemador 4300 con retenedor
33	Connector 4-pole white BR II	Borne de connexion 4- pôles BR II blanc	Morsetto di collegamento 4-bipolare BR II	Aansluitklem 4- polig BR II wit	Borne de conexión 4-polos BR II blanc
34	Burner connector 4-pole green	Connecteur 4 poles vert	Spina 4-bipolare verde	Stekker 4-polig groen	Enchufe 4-polos verde
35	Burner cable extension 700mm long	Rallonge câble br#leur long.700mm	Linea del bruciatore Prolunga 700mm	Branderleiding Verlenging 700mm	Cable del quemador Prolongación 700mm
36	Female contact ST18/4 with strain relief	Douille ST 18/4 + Sert-cable	Boccola ST 18/4 + Fermo antitrazione	Huls ST 18/4 + Trekontlasting	Contacto ST 18/4 con retenedor
37	Burner connector 4-pole green	Connecteur 4 poles vert	Spina 4-bipolare verde	Stekker 4-polig groen	Enchufe 4-polos verde
38	Installation material S625/725	MATERIEL MONTAGE HABIL S625/725	Materiale per il montaggio S625/725	Montagemateriaal S625/725	Material de montaje S625/S728
	Paint spray RAL5013 400ml cobalt blue	Peinture Bombe RAL5013 400ml	Bomboletta Spray RAL 5013 400ml	Lak RAL5013Sprühdose 400ml	Spray pintura RAL 5013 400ml azul
	Cable entry (slotted) (1x)	PASSE CABLE BLEU CIEL RAL 5015 (1x)	Passacavo (blu) (1x)	Kabeldoorvoer met sleuven (blauw) (1x)	Tapa frontal pasacables azul
	Aerosol paint RAL5015 150ml (sky blue)	PEINTURE BOMBE RAL 5015 150 ML BLEU CIEL	Bombola spray RAL5015 150ml (azzurro)	Spruitbus RAL5015 150ml (hemelsblauw)	Botte de spray RAL5015 150ml azul celeste
5	Element of construction	Grupo de construction	Gruppo di costruzione	Montagegroep	Grupo de construccion
1	Hood middle S625 230-690kW	Capot milieu S625 230-690kW	Coperchio intermedio S625 230-690kW	Afdekkap midden S625 230-690KW	Carcasa superior central S625 230-690KW
2	Hood rear part C S625/S725	Capot arri#re Partie C S625/S725	Coperchio posteriore Parte C S625/S725	Afdekkap Achter Deel C S625/S725	Carcasa superior Parte C S625/S725
3	Hood rear part B S625/S725	Capot arri#re Partie B S625/S725	Coperchio posteriore Parte B S625/S725	Afdekkap Achter Deel B S625/S725	Carcasa superior Parte B S625/S725
4	Hood rear S725 1070-1600kW	Capot arri#re S725 1070-1600kW	Coperchio posteriore S725 1070-1600kW	Afdekkap Achter S725 1070-1600KW	Carcasa superior trasera S725

Übersetzungsliste List of translations		Liste des traductions Traduzione delle descrizioni		Vertalinglijst Lista de traducciones	
Pos	Description	Denomination	Descrizione	Benaming	Descripción
5	Hood middle S725 870-1600kW	Capot milieu S725 870-1600kW	Coperchio intermedio S725 870-1600kW	Afdekkap midden S725 870-1600kW	Carcasa superior central S725 870-1600kW
6	Element of construction	Groupe de construction	Gruppo di costruzione	Montagegroep	Grupo de construcción
1	Side control unit support for Logamatic	Support lateral pour regulation 4000	Supporto Quadro comandi 4212/4311/HS4312	Schakelkasthouder 4212/4321/4322	Soporte para regulación 4311, 4312 para
2	Bearing arm for control panel RAL 5015	Plaque de jonction de base RAL 5015	Supporto sotto Apparecchio di regolazione	Draaier Onder Regel en best. app. RAL 50	Soporte debajo aparato de regulación
3	Cover fixing bracket	Couvercle Plaque de jonction	Coperchio Supporto	Afdekking Drager	Recubrimiento Soporte GE615
4	Pan-head screw ST3,9x9,5 A3T (10x)	Vis # t#te plate ST3,9 (10x)	Vite a testa piana ST3,9x9,5 (10x)	Schroef met vlakke kop ST3,9x9,5 (10x)	Tornillo avellanado ST3,9x9,5 (10x)
5	Facing plate for bracket control panel	Tôle de protection	Lamierina di protezione	Afdekkplaat	Chapa de recubrimiento
8	Facing panel cable entry (blue)	Tôle de protection Passe-câble (bleu)	Lamierina di protezione Passacavo (blu)	Afdekkplaat kabeldoorvoer (blauw)	Tapa Frontal pasacables
9	Cable entry (slotted) (1x)	PASSE CABLE BLEU CIEL RAL 5015 (1x)	Passacavo (blu) (1x)	Kabeldoorvoer met sleuven (blauw) (1x)	Tapa frontal pasacables azul
10	Hood for control panel HS 4311/4312	Capot HS 4311/4312	Coperchio HS 4311/4312	Afdekkap HS 4311/4312	Chapa para regulación HS 4311/4312
11	Burner wire 8M	Cable brul 2 allures 8m	Cavo bruciatore 8000 per 2-stadio	Branderkabel2-trap8000mm S625/725/735/50	Cable del quemador 8M -2Nivel del
13	Hood rear part B S625/S725	Capot arri#re Partie B S625/S725	Coperchio posteriore Parte B S625/S725	Afdekkap Achter Deel B S625/S725	Carcasa superior Parte B S625/S725
14	Hood rear part C S625/S725	Capot arri#re Partie C S625/S725	Coperchio posteriore Parte C S625/S725	Afdekkap Achter Deel C S625/S725	Carcasa superior Parte C S625/S725
15	Hood rear part A S625 690kW	Dessus arri#re part.A S625-690 compl.	Coperchio posteriore A S625 690kW	Afdekkap Achter A S625 690kW	Carcasa media trasera Parte A
15	Hood rear part A S725 870kW	Dessus arri#re A S725 870kW	Coperchio posteriore A S725 870kW	Afdekkap Achter A S725 870kW	Carcasa superior Parte A S725 870kW
15	Hood rear part A S725 1070-1320kW	Dessus arri#re A S725 1070-1320kW	Coperchio posteriore A S725 1070-1320kW	Afdekkap Achter A S725 1070-1320kW	Carcasa superior Parte A S725
15	Hood rear part A S725 1600kW	Dessus arri#re A S725 1600kW	Coperchio posteriore A S725 1600kW	Afdekkap Achter A S725 1600kW	Carcasa superior Parte A S725 1600kW
16	Installation material support for	Matériel de montage Plaque de jonction	Materiale per il montaggio Supporto sott	Montagemateriaal Draaier Onder Regel	Material de montaje soporte regulación
7	Element of construction	Groupe de construction	Gruppo di costruzione	Montagegroep	Grupo de construcción
1	Sound-absorbing boiler plinth S625 size	Socle de chaudi#re S625-230/310kW	Sottofondo caldaia S625-230/310kW	Ketelsokkel S625-230/310kW	Railes insonorización S625-230/313
1	Sound-absorbing boiler plinth	RAIL INSONORISATION SB 735/790KW	BASAM.CALDAIA FONOAASSORBENTE790KW	Ketelframe sb735-790/s725-870	Railes insonorización S725-870,
1	Boiler plinth S725-1070/1320kW,	RAIL INSONORISATION SB735 970 KW	BASAM.CALDAIA FONOAASSORBENTE	Ketelframe s7x5/970-1070-1320	Railes insonorización S725-1070/1320
1	Sound-absorbing boiler plinth S725 size	Socle de chaudi#re POUR SE 725 1600 KW	Sottofondo caldaia S725-1600kW	Ketelfram s725-1600	Railes insonorización S725-1603
2	Exhaust silencer DN250 Steel	PIEGE SON DN250 ACIER	SILENZIATORE DN 250	Schouwgeluiddemper DN250 voor G515	Silenciador chimenea DN250 GE515
2	Flue gas silencer of steel, DN 300	PIEGE SON DN300 ACIER	SILENZIATORE DN300	Rookgasgeluiddemper, DN 300	Silenciador chimenea, DN 300
2	Flue Gas Silencer	PIEGE SON DN360 ACIER	SILENZIATORE DN360	Schouwgeluiddemper DN360 voor	Silenciador chimenea DN360 para GE 615
3	Flue pipe sealing collars DN250	MANCHET ETANCHE DN250	Guarnizione a flangia DN250	Rookgasafdichtingsmof diam.250	Manguito estanqueidad silenciador DN 250
3	Flue pipe sealing collars DN300	Manchette d'étanchéité DN300 compl.	Guarnizione a flangia DN300	Afdichtmanchet voor de rookgasafvoerbu	Manguito estanqueidad silenciador DN 300
3	Flue pipe sealing collars DN360	Manchette d'étanchéité DN360	Guarnizione a flangia DN360	Afdichtmanchet voor de rookgasafvoerbu	Manguito estanqueidad GE615. DN360
8	Element of construction	Groupe de construction	Gruppo di costruzione	Montagegroep	Grupo de construcción
2	Fitting assembly, triple, cap valve 3/4"	Tuyau distributeur 3/4"	Collet.3 sic.Pressione bloccoValvola 3/4	Armaturen balk 3/4"	Colector de conexiones triple con valv
3	Cap valve with KFE-Valve	Robinet	Valvola	Ventiel	Válvula
4	Pressure gauge valve MS 1/2", PN250 with	Soupape de manom#tre MS 1/2", PN250	Manometro-Valvola Ms 1/2", PN250	Manometer-Ventiel Ms 1/2", PN250	Válvula para manómetro 1/2", PN250
5	Pressure gauge 100mm D1/2" 0-10bar	Manometre d:100 mm, 0-10bar 1/2"	Manometro davanti d:100mm, 0-10bar 1/2"	Manometer vooraan d:100mm, 0-10bar 1/2"	Manómetro delante d:100mm, 0-10bar 1/2"
6	Kit Plug for safety armatures groupe	JEU DE BOUCHONS PR GROUPE DE SECURITE	Tappo Set	Doorvoertule Set	Tapón set
7	Sensor well G1/2" 100mm long	Doigt de gant G 1/2" 100mm de long.	Pozzetto ad immersione G 1/2" 100mm	Dompelhuls G 1/2" 100mm	Vaina de inmersión G 1/2" 100mm
8	Thermometer D100 G1/2 0 - 120° C 100mm	Thermom#tre D100 G1/2 0-120°C long.100mm	Termometro D100 G1/2 0 - 120° C 100mm	Thermometer D100 G1/2 0 - 120° C 100mm	Termómetro D100 G1/2 0 - 120° C 100mm
9	Limiter water level SYR 933,20,11	Régleur de débit eau SYR 933,20,11	Regolatore portata SYR 933,20,11	Waterdebietregelaar SYR 933,20,11	Limitador nivel de agua SYR 933,20,11
10	Gasket kit KSG	JEU DE JOINTS KSG	Set guarnizioni KSG	Set afdichting KSG	Juego de juntas KSG
11	Gasket Klingersil C4400 PN6 DN80	Joint contre bride pn6 DN80	Guarnizione PN6 DN80 2mm, 90/132D	Pakking PN6 DN80 2mm, 90/132D	Junta plana C4400 PN6 DN80
11	Gasket Klingersil C4400 PN6 DN100	Joint contre bride pn6 DN100	Guarnizione PN6 DN100 2mm, 115/152D	Pakking PN6 DN100 2mm, 115/152D	Junta plana C4400 PN6 DN100, 115/152D
11	Gasket Klingersil C4400 PN6 DN125	Joint contre bride pn6 DN125	Guarnizione KLINGERSil C4400 PN6 DN125	Pakking KLINGERSil C4400 PN6 DN125	Junta plana C4400 PN6 DN125, 141/182D
11	Gasket DIN2690 DN150 PN6	Joint contre bride c4400 pn6 DN150	Guarnizione KLINGERSil C4400 PN6 DN150	Pakking KLINGERSil C4400 PN6 DN150	Junta plana DIN2690 DN150 PN6
13	Washer ISO 7089 A17 A3K (2x)	Rondelle ISO 7089 A17 A3K (2x)	Rondella ISO 7089 A17 A3K (2x)	Ring ISO 7089 A17 A3K (2x)	Arandela ISO 7089 A17 A3K (2x)
14	Nut ISO4032 M16 8 A3K (2x)	Écrou ISO4032 M16 8 A3K (2x)	Dado ISO4032 M16 8 A3K (2x)	Moer ISO4032 M16 8 A3K (2x)	Tuerca ISO4032 M16 8 A3K (2x)
9	Element of construction	Groupe de construction	Gruppo di costruzione	Montagegroep	Grupo de construcción
	Composit-pipe SE625-230/310KW	Composit-Tube S/SE625 230-310kW	Composit-Tubo S/SE625 230-310kW	Composit-Pijp S/SE625 230-310kW	Tubo S/SE625 230-310kW
	Composit-pipe SE625-410/530/690	Composit-Tube S/SE625 410-690kW	Composit-Tubo S/SE625 410-690kW	Composit-Pijp S/SE625 410-690kW	Tubo S/SE625 410-690kW
	Composit-pipe SE725-870KW	Composit-Tube S/SE725 870kW	Composit-Tubo S/SE725 870kW	Composit-Pijp S/SE725 870kW	Tubo S/SE725 870kW
	Composit-pipe SE725-1070/1320KW	Composit-Tube S/SE725 1070-1320kW	Composit-Tubo S/SE725 1070-1320kW	Composit-Pijp S/SE725 1070-1320kW	Tubo S/SE725 1070-1320kW
	Composit-pipe SE725-1600KW	Composit-Tube S/SE725 1600kW	Composit-Tubo S/SE725 1600kW	Composit-Pijp S/SE725 1600kW	Tubo S/SE725 1600kW
	Repair substance Calde Stix14 G3, 25kg	Masse de réparation Calde Stix14 G3, 25kg	Reparaturmasse Calde Stix14 G3, 25kg	Reparaturmasse Calde Stix14 G3, 25kg	Sustancia reparadora plistix 14, 25kg
	Rep-set angle sheet S625-230/310	Reparation-Set Equerre Tôle S625-230/310	Riparazione-Set Angolo Lamierino 230/310	Repair-Set Hoeksteun Blik S625-230/310	Set de reparación ángulo chapa 230/310
	Rep-set angle sheet S625-410/530	Reparation-Set Equerre Tôle S625-410/530	Riparazione-Set Angolo Lamierino 410/530	Repair-Set Hoeksteun Blik S625-410/530	Set de reparación ángulo chapa 410/530
	Rep-set angle sheet S625-690/725-870	Reparation-Set Equerre Tôle 690/870	Riparazione-Set Angolo Lamierino 690/870	Repair-Set Hoeksteun Blik 690/870	Set de reparación ángulo chapa 690/870
	Rep-set angle sheet S725-1070/1320	Reparation-Set Equerre Tôle 1070/1320	Riparazione-Set Angolo Lamierino	Repair-Set Hoeksteun Blik S725-1070/1320	Set de reparación ángulo chapa 1070/1320
	Rep-set angle sheet S725-1600	Reparation-Set Equerre Tôle S725-1600	Riparazione-Set Angolo Lamierino 1600	Repair-Set Hoeksteun Blik S725-1600	Set de reparación ángulo chapa 1600

Gerätetypen Types of appliances	Types de chaudières Tipo apparecchi		Toesteltypes Tipos de aplicaciones	
Gerät Appliance Chaudière Apparecchio Toestel Aparato	Bestell-Nr. Ordering no. Numéro de commande N° d'ordine Bestellnummer Número el ordenar	Land Country Pays Paese Land Paese	S-Nr. S-Nr. S-Nr. S-Nr. S-Nr. S-Nr.	Bemerkungen Remarks Remarques Osservazioni Opmerkingen Observaciones
SE625-230	7 747 302 809	Deutschland		
SE625-230	5791605	Deutschland		
SE625-310	7 747 303 428	Deutschland		
SE625-310	7 747 302 810	Deutschland		
SE625-310	5791615	Deutschland		
SE625-410	7 747 303 429	Deutschland		
SE625-410	7 747 302 811	Deutschland		
SE625-410	5791625	Deutschland		
SE625-530	5791635	Deutschland		
SE625-530	7 747 302 812	Deutschland		
SE625-530	7 747 303 430	Deutschland		
SE625-690	7 747 303 431	Deutschland		
SE625-690	7 747 302 813	Deutschland		
SE625-690	5791645	Deutschland		
SE725-870	7 747 302 814	Deutschland		
SE725-870	5785305	Deutschland		
SE725-870	7 747 303 437	Deutschland		
SE725-1070	7 747 303 438	Deutschland		
SE725-1070	7 747 302 815	Deutschland		
SE725-1070	5785315	Deutschland		
SE725-1070 S	63007004	Deutschland		
SE725-1320	5785325	Deutschland		
SE725-1320	7 747 302 816	Deutschland		
SE725-1320	7 747 303 439	Deutschland		
SE725-1320 S	7023155	Deutschland		
SE725-1320 S	63007005	Deutschland		
SE725-1600	7 747 303 440	Deutschland		
SE725-1600	7 747 302 817	Deutschland		
SE725-1600	5785335	Deutschland		
SE725-1600 S	63135002	Deutschland		
SE625-230	30004792	England		
SE625-230	30008703	England		
SE625-310	30008704	England		

Gerätetypen Types of appliances	Types de chaudières Tipo apparecchi		Toesteltypes Tipos de aplicaciones	
Gerät Appliance Chaudière Apparecchio Toestel Aparato	Bestell-Nr. Ordering no. Numéro de commande N° d'ordine Bestelnummer Número el ordenar	Land Country Pays Paese Land Paese	S-Nr. S-Nr. S-Nr. S-Nr. S-Nr. S-Nr.	Bemerkungen Remarks Remarques Osservazioni Opmerkingen Observaciones
SE625-310	30004793	England		
SE625-410	30008705	England		
SE625-410	30004794	England		
SE625-530	30004795	England		
SE625-530	30008706	England		
SE625-690	30004796	England		
SE625-690	30008707	England		
SE725-870	30004801	England		
SE725-870	30008708	England		
SE725-1070	30008709	England		
SE725-1070	30004802	England		
SE725-1320	30004803	England		
SE725-1320	30008710	England		
SE725-1600	30008711	England		
SE725-1600	30004804	England		
SE625-310	30004168	Frankreich		
SE625-410	30004169	Frankreich		
SE625-530	30004170	Frankreich		
SE625-690	30004171	Frankreich		
SE725-870	30004172	Frankreich		
SE725-1070	30004173	Frankreich		
SE725-1320	30004174	Frankreich		
SE725-1600	30004175	Frankreich		
SE625-230	30005420	Italien		
SE625-310	30005421	Italien		
SE625-410	30005422	Italien		
SE625-530	30005423	Italien		
SE625-690	30005424	Italien		
SE725-870	30005425	Italien		
SE725-1070	30005426	Italien		
SE725-1320	30005427	Italien		
SE725-1600	30005428	Italien		

Gerätetypen Types of appliances	Types de chaudières Tipo apparecchi		Toesteltypes Tipos de aplicaciones	
Gerät Appliance Chaudière Apparecchio Toestel Aparato	Bestell-Nr. Ordering no. Numéro de commande N° d'ordine Bestelnummer Número el ordenar	Land Country Pays Paese Land Paese	S-Nr. S-Nr. S-Nr. S-Nr. S-Nr. S-Nr.	Bemerkungen Remarks Remarques Osservazioni Opmerkingen Observaciones
SE625-230	30008690	Litauen		
SE625-310	30008691	Litauen		
SE625-410	30008692	Litauen		
SE625-530	30008693	Litauen		
SE625-690	30008694	Litauen		
SE725-870	30005558	Niederlande		
SE725-1070	30005559	Niederlande		
SE725-1320	30005560	Niederlande		
SE725-1600	30005561	Niederlande		
SE625-310	30006691	Rumänien		
SE625-410	30006692	Rumänien		
SE625-690	30006694	Rumänien		
SE725-870	30006695	Rumänien		
SE725-1070	30006696	Rumänien		
SE725-1070 S	30006699	Rumänien		
SE725-1320	30006697	Rumänien		
SE725-1320 S	30006700	Rumänien		
SE725-1600	30006698	Rumänien		
SE725-1600 S	30006701	Rumänien		
SE625-310	30002650	Slowakei		
SE625-410	30002651	Slowakei		
SE625-530	30002652	Slowakei		
SE625-690	30002653	Slowakei		
SE725-870	30002658	Slowakei		
SE725-1070	30002659	Slowakei		
SE725-1320	30002660	Slowakei		
SE725-1600	30002661	Slowakei		
SE625-310	30006343	Spanien		
SE625-410	30006344	Spanien		

Gerätetypen Types of appliances	Types de chaudieres Tipo apparecchi	Toesteltypes Tipos de aplicaciones		
Gerät Appliance Chaudière Apparecchio Toestel Aparato	Bestell-Nr. Ordering no. Numéro de commande N° d'ordine Bestelnummer Número el ordenar	Land Country Pays Paese Land Paese	S-Nr. S-Nr. S-Nr. S-Nr. S-Nr. S-Nr.	Bemerkungen Remarks Remarques Osservazioni Opmerkingen Observaciones
SE625-530	30006345	Spanien		
SE625-690	30006346	Spanien		
SE725-870	30006347	Spanien		
SE725-1070	30006348	Spanien		
SE725-1320	30006349	Spanien		
SE725-1600	30006350	Spanien		
SE625-410	30002646	Tschechische Republik		
SE625-530	30002647	Tschechische Republik		
SE625-690	30002648	Tschechische Republik		
SE725-870	30002654	Tschechische Republik		
SE725-1070	30002655	Tschechische Republik		
SE725-1320	30002656	Tschechische Republik		
SE725-1600	30002657	Tschechische Republik		
SE625-310	30006828	Türkei		
SE625-410	30006829	Türkei		
SE625-530	30006830	Türkei		
SE625-690	30006831	Türkei		
SE725-870	30006837	Türkei		
SE725-1070	30006838	Türkei		
SE725-1320	30006839	Türkei		
SE725-1600	30006840	Türkei		

Bosch Thermotechnik GmbH
Sophienstr. 30-32
D-35576 Wetzlar / Germany

Buderus