

GB172i.2 15-24 W W H

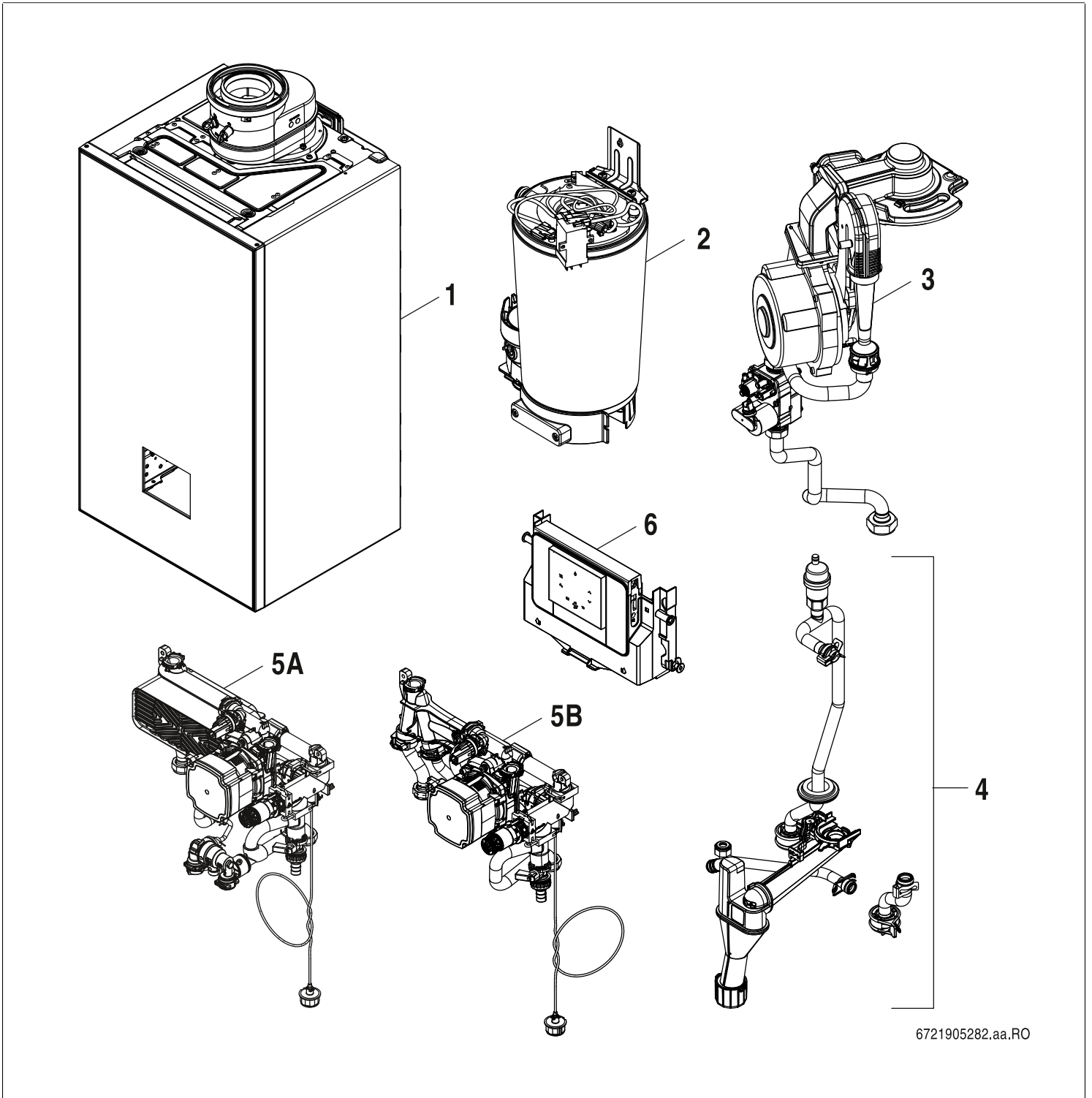

6721905282.aa.RO

[de] Wichtige Hinweise zur Installation/Montage

Die Installation/Montage muss durch eine für die Arbeiten zugelassene Fachkraft unter Beachtung der geltenden Vorschriften erfolgen.

[en] Important notes on installation/assembly

The installation/assembly must be carried out by a qualified contractor, following these instructions and in compliance with the applicable regulations.

[fr] Instructions importantes pour l'installation/le montage

L'installation/le montage doit être effectué(e) par un spécialiste qualifié pour les opérations concernées et dans le respect de la présente notice et des prescriptions applicables.

[bg] Важни указания във връзка с инсталацията/монтажа

Инсталацията/монтажът трябва да се извършва от лицензиран за работите специалист в съответствие с настоящото ръководство и с приложимите разпоредби.

[cs] Důležité pokyny k instalaci/montáži

Instalaci/montáž musí při dodržení pokynů uvedených v tomto návodu a platných předpisů provést odborný pracovník s příslušným oprávněním pro tyto práce.

[da] Vigtige anvisninger til installationen/monteringen

Installationen/monteringen skal foretages af en godkendt installatør under overholdelse af denne vejledning og de gældende forskrifter.

[el] Σημαντικές υποδείξεις για την εγκατάσταση/συναρμολόγηση

Η εγκατάσταση/τοποθέτηση πρέπει να ανατίθεται σε εκπαιδευμένο για τις συγκεκριμένες εργασίες τεχνικό προσωπικό με τήρηση αυτών των οδηγιών καθώς και των σχετικών προδιαγραφών.

[es] Indicaciones importantes para instalación/montaje

La instalación/el montaje debe realizarla personal especializado que esté autorizado para realizar estos trabajos y que tenga en cuenta estas instrucciones y la normativa vigente.

[et] Olulised juhised paigaldamiseks/montaažiks

Paigaldamist/montaaži tohib läbi viia vaid selleks volitusi omav spetsialist, arvestades kehtivaid nõudeid.

[nl-BE] Belangrijke aanwijzingen betreffende de installatie/montage

De installatie/montage moet worden uitgevoerd door een voor de werkzaamheden geautoriseerde installateur rekening houdend met deze handleiding en de geldende voorschriften.

[fi] Tärkeitä asennus- ja kokoonpano-ohjeita

Näihin töihin hyväksytyin ammattiasentajan pitää suorittaa asennus- ja kokoonpanotyöt voimassa olevien määräysten mukaisesti.

[hu] Fontos tudnivalók az installáláshoz/szereléshez

A telepítést/szerelést egy, a munkálatokra felhatalmazott szakembernek kell végeznie, jelen utasítás és az érvényes előírások figyelembevételével.

[it] Avvertenze importanti per l'installazione/il montaggio

L'installazione/il montaggio deve aver luogo ad opera di una ditta specializzata ed autorizzata in osservanza di queste istruzioni e delle direttive vigenti.

[ka] მნიშვნელოვანი მითითებები ინსტალაციისთვის/მონტაჟისთვის

ინსტალაცია/მონტაჟი უნდა განხორციელდეს საშუალებისთვის დამკვეთი კვალიფიციური პერსონალის მიერ, მოქმედი განაწესის დაცვით.

[lt] Svarbios instaliavimo ir (arba) montavimo nuorodos

Instaliavimo / montavimo darbus, laikydamiesi šios instrukcijos reikalavimų ir galiojančių taisyklių, privalo atlikti šioms darbams įgalioti specialistai.

[lv] Svarīgi norādījumi par iekārtas uzstādīšanu / montāžu

Uzstādīšanu/montāžu jāveic atbilstošajiem darbiem sertificētam speciālistam, ievērojot šo instrukciju un spēkā esošos noteikumus.

[nl] Belangrijke aanwijzingen betreffende de installatie/montage

De installatie/montage moet door een erkend installateur volgens de geldende voorschriften worden uitgevoerd.

[no] Viktig informasjon om installasjon/montering

Installasjonen/monteringen skal gjennomføres av autoriserte installatører, og installasjonsanvisningen samt gjeldende forskrifter skal følges.

[pl] Ważne wskazówki dotyczące instalacji/montażu

Instalację/montaż powinien wykonać specjalista uprawniony do tego typu prac z uwzględnieniem informacji podanych w niniejszej instrukcji oraz aktualnie obowiązujących przepisów.

[pt] Indicações importantes relativas à instalação/montagem

A instalação/montagem deve ser efectuada por um técnico autorizado para os trabalhos, respeitando este manual e as prescrições válidas.

[ro] Indicații importante privind instalarea/montajul

Instalarea/montajul trebuie realizate de către un specialist autorizat pentru lucrările respective, respectându-se prezentele instrucțiuni și prescripțiile valabile.

[ru] Важные указания по подключению/монтажу

Подключение/монтаж должны выполнять только специалисты, имеющие допуск к выполнению таких работ, при соблюдении требований этой инструкции и действующих норм и правил.

[sk] Dôležité pokyny týkajúce sa inštalácie/montáže

Inštaláciu/montáž musí vykonať odborný personál, ktorý má oprávnenie pre výkon týchto prác, pričom musí dodržiavať pokyny uvedené v tomto návode a platné predpisy.

[sl] Pomembni napotki za namestitvev/montažo

Inštalacijo/montažo lahko izvede samo pooblaščen strokovnjak ob upoštevanju teh navodil in veljavnih predpisov.

[sr] Važna uputstva za ugradnju i montažu

Ovu instalaciju/montažu moraju da obave stručna lica koja su ovlašćena za obavljanje takvih radova u skladu sa ovim uputstvom i važećim propisima.

[sv] Viktiga anvisningar för installation/montering

Installationen/monteringen måste utföras av en behörig och tekniskt utbildad person enligt denna anvisning samt gällande föreskrifter.

[tr] Kurulum/Montaj ile ilgili önemli uyarılar

Kurulum/montaj, bu çalışmalarını yapmasına müsaade edilen uzman kişiler tarafından işbu kılavuz ve geçerli yönetmelikler dikkate alınarak yapılmalıdır.

[uk] Важливі вказівки щодо установки/монтажу

Встановлення/монтаж повинні виконувати фахівці, що допущені до виконання таких робіт, із дотриманням цієї інструкції та діючих приписів.

[zh] 安装方面的重要提示

安装和组装工作必须由经过许可的专业人员进行, 同时必须遵守本说明书和现行法规的相关要求

[ar] ملاحظات هامة للتركيب/التجميع
يجب أن يتم التركيب/التجميع من قبل متخصص مصرح له بالعمل، مع مراعاة اللوائح السارية.

[fa] تذکرات مهم درباره نصب/مونتاژ
نصب/مونتاژ باید توسط فردی حرفه ای که مجاز به انجام این کار است، و همچنین با توجه کامل به مقررات مربوطه انجام شود.

[az] Quraşdırılma

Quraşdırılma işinin yerinə yetirilməsi səlahiyyətli bir mütəxəssis tərəfindən və müvafiq qaydalara uyğun olaraq aparılmalıdır.

Spare parts list
Ersatzteilliste

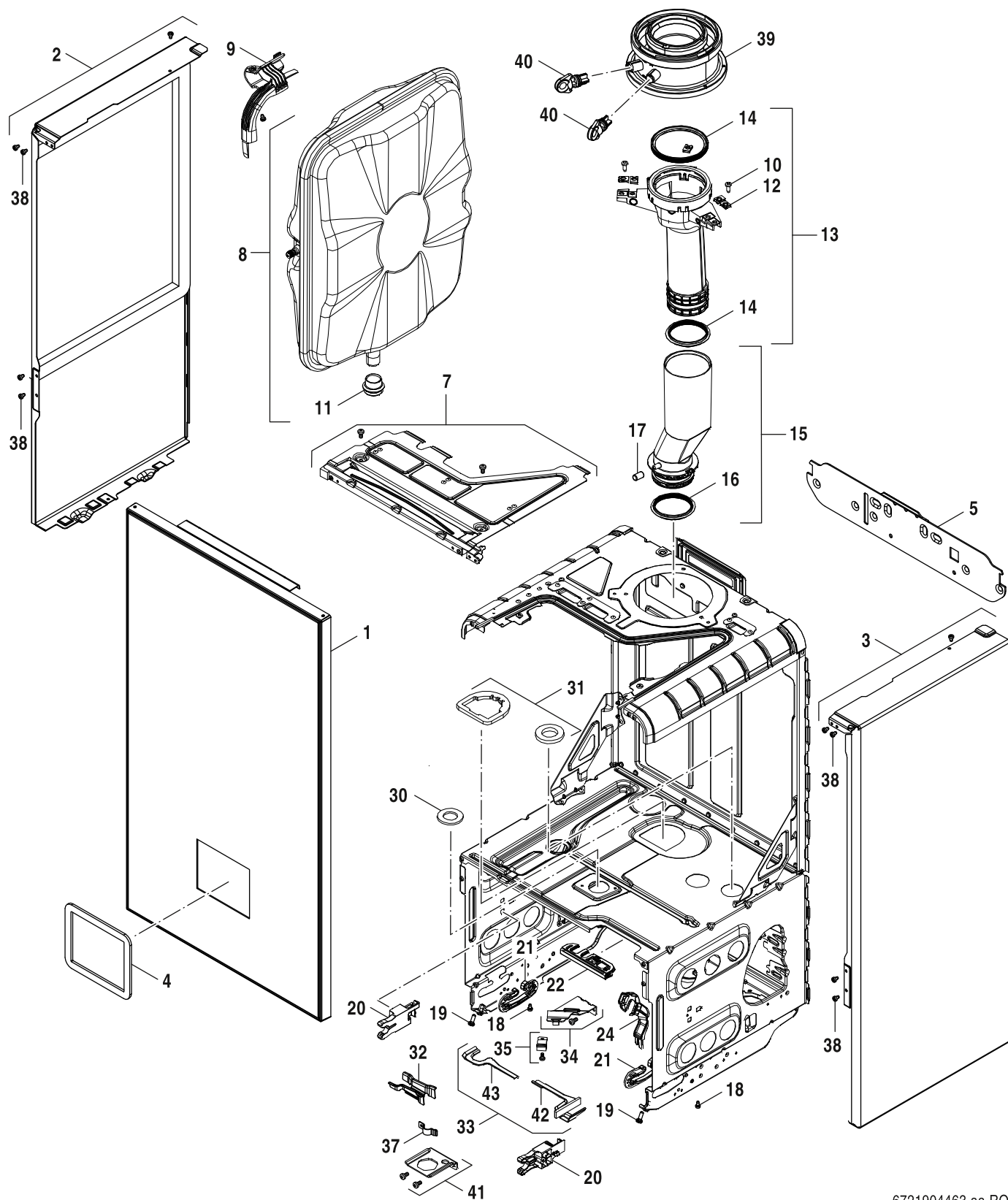

6721904463.aa.RO

Sheet metal
Blechteile

GB172i.2 15-24 W W H

1

Spare parts list
Ersatzteilliste

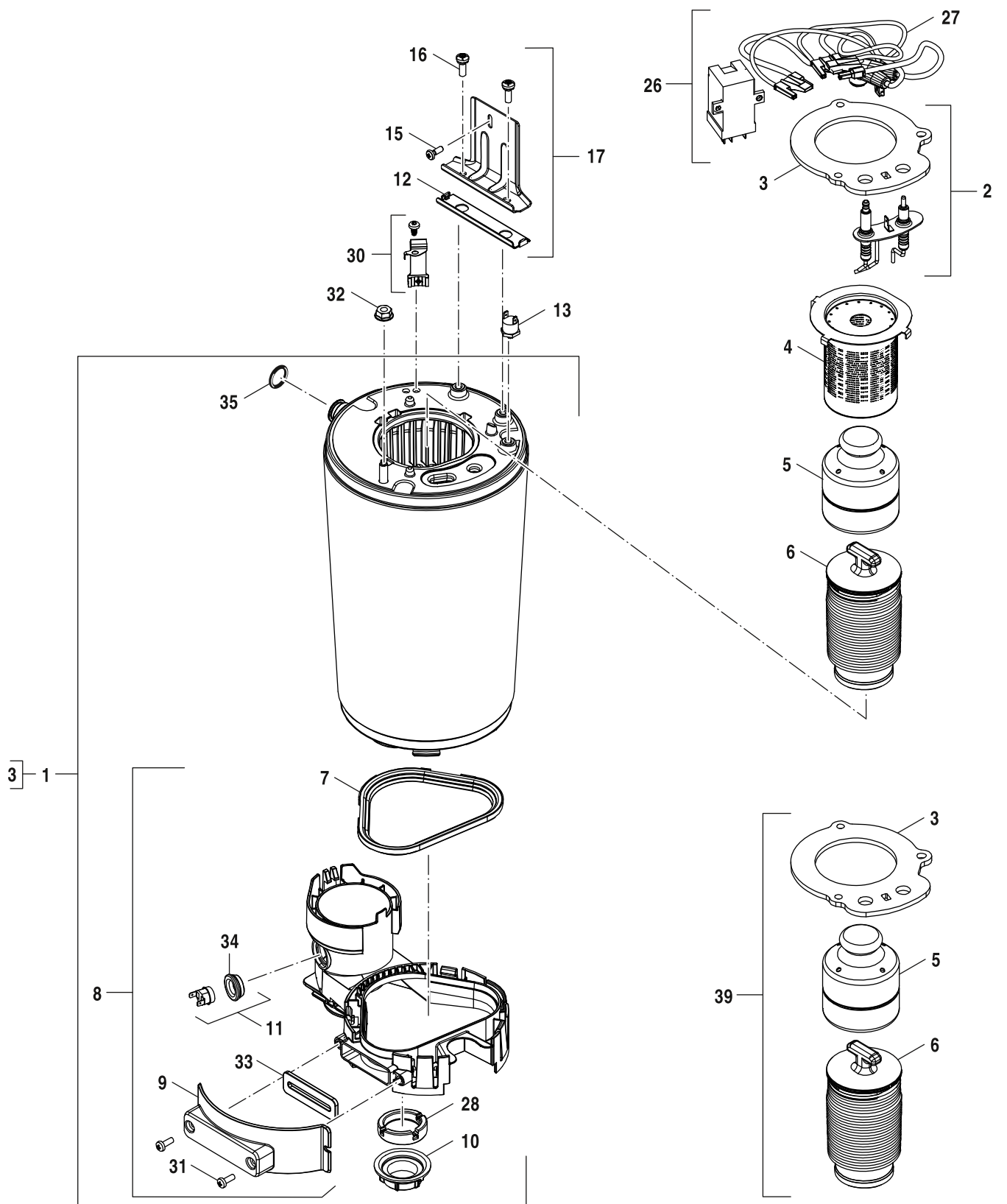

6721904465.ab.RO

Heat exchanger
Wärmeübertrager

GB172i.2 15-24 W W H

2

Pos	Description Bezeichnung	Ordering no. Bestell-Nr.																	Remarks Bemerkungen
			7-736-902-489	7-736-902-490	7-736-902-491														
1	Heat exchanger C6-13 (coated)	8 737 604 784	■	■	■														
2	Electrode set	8 737 903 536 0	■	■	■														
3	Seal burner	8 718 650 789 0	■	■	■														
4	Burner 15 kW	8 718 650 983 0	■	■															
4	Burner 30 kW	8 718 650 984 0	■	■	■														
5	Displacement body	8 715 405 197 0	■	■	■														
6	Lower baffle	8 737 602 342	■	■	■														
7	Seal	8 718 651 071 0	■	■	■														
8	Assembly Condensate Tray Bosch	8 716 121 187	■	■	■														
9	Cover (Installer access)	8 718 651 585 0	■	■	■														
10	Nut	8 713 301 196 0	■	■	■														
11	Temperature limiter	8 710 506 267 0	■	■	■														
12	Plate	8 716 121 838	■	■	■														
13	Temperature limiter	8 737 903 399 0	■	■	■														
15	Screw M5x8 (10x)	8 737 602 552	■	■	■														
16	Screw M6x18 (10x)	8 737 602 143	■	■	■														
17	Bracket	8 737 711 804	■	■	■														
26	Ignition transformer	7 736 700 599	■	■	■														
27	Ignition Cable	8 737 902 999 0	■	■	■														
28	Seal Condensate Tray	8 716 117 038	■	■	■														
30	Temperature sensor NTC	8 737 602 343	■	■	■														
31	Screw M5x14 (10x)	8 716 012 033 0	■	■	■														
32	Nut M8 with flange	8 718 682 332 0	■	■	■														
33	Seal	8 737 902 502 0	■	■	■														
34	Grommet	8 737 902 638 0	■	■	■														
35	O-ring 17x4 (10x)	8 716 771 154 0	■	■	■														
39	Baffle Set	8 716 121 956	■	■	■														
	Cleaning set C6	7 738 113 218	■	■	■														
	Service-Kit C6-13	8 737 711 853	■	■	■														

GB172i.2 15-24 W W H	Heat exchanger Wärmeübertrager	2
-----------------------------	-----------------------------------	----------

Spare parts list
Ersatzteilliste

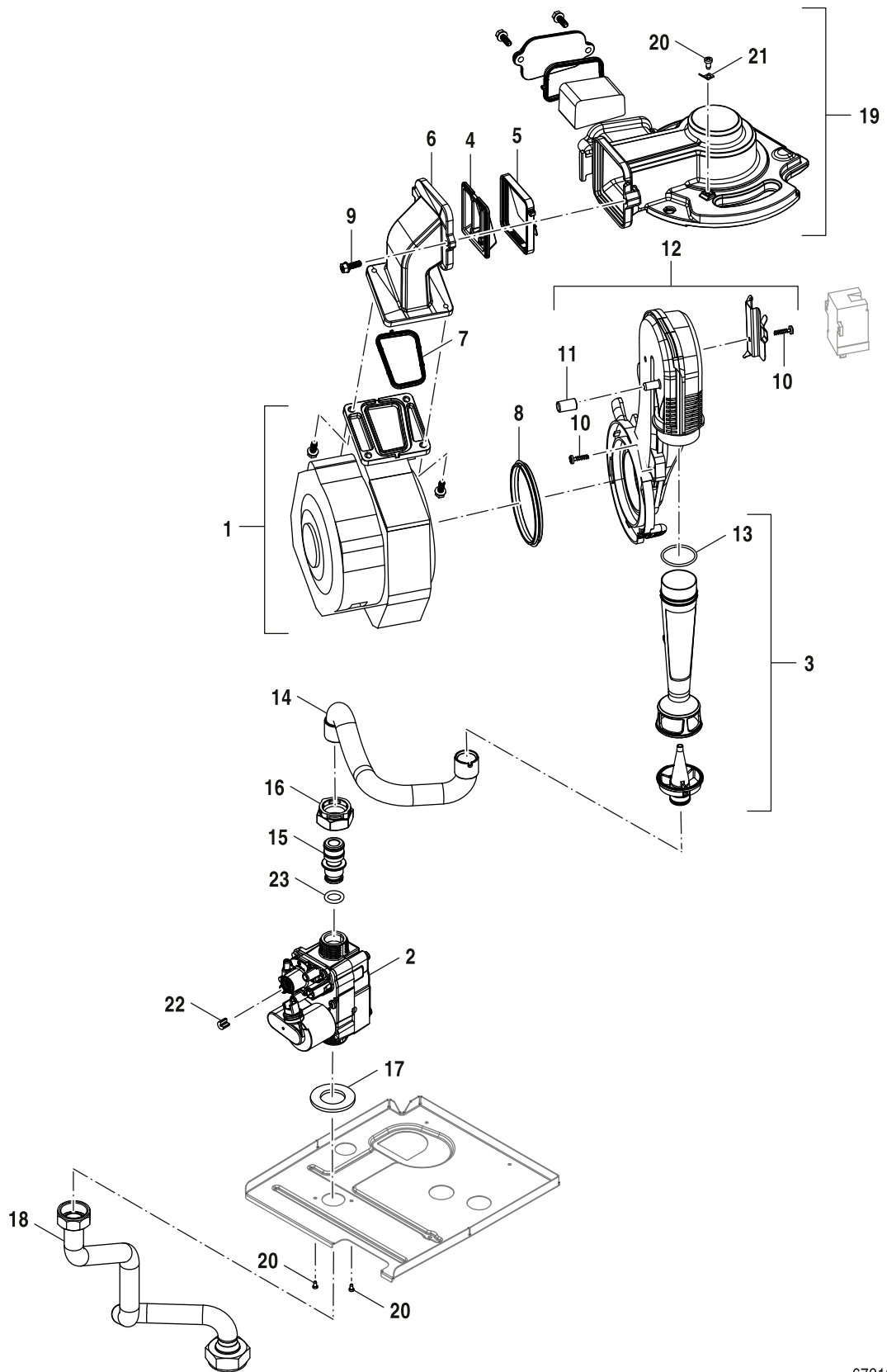

6721904467.aa.RO

Gas valve
Gasarmatur

GB172i.2 15-24 W W H

3

Spare parts list
Ersatzteilliste

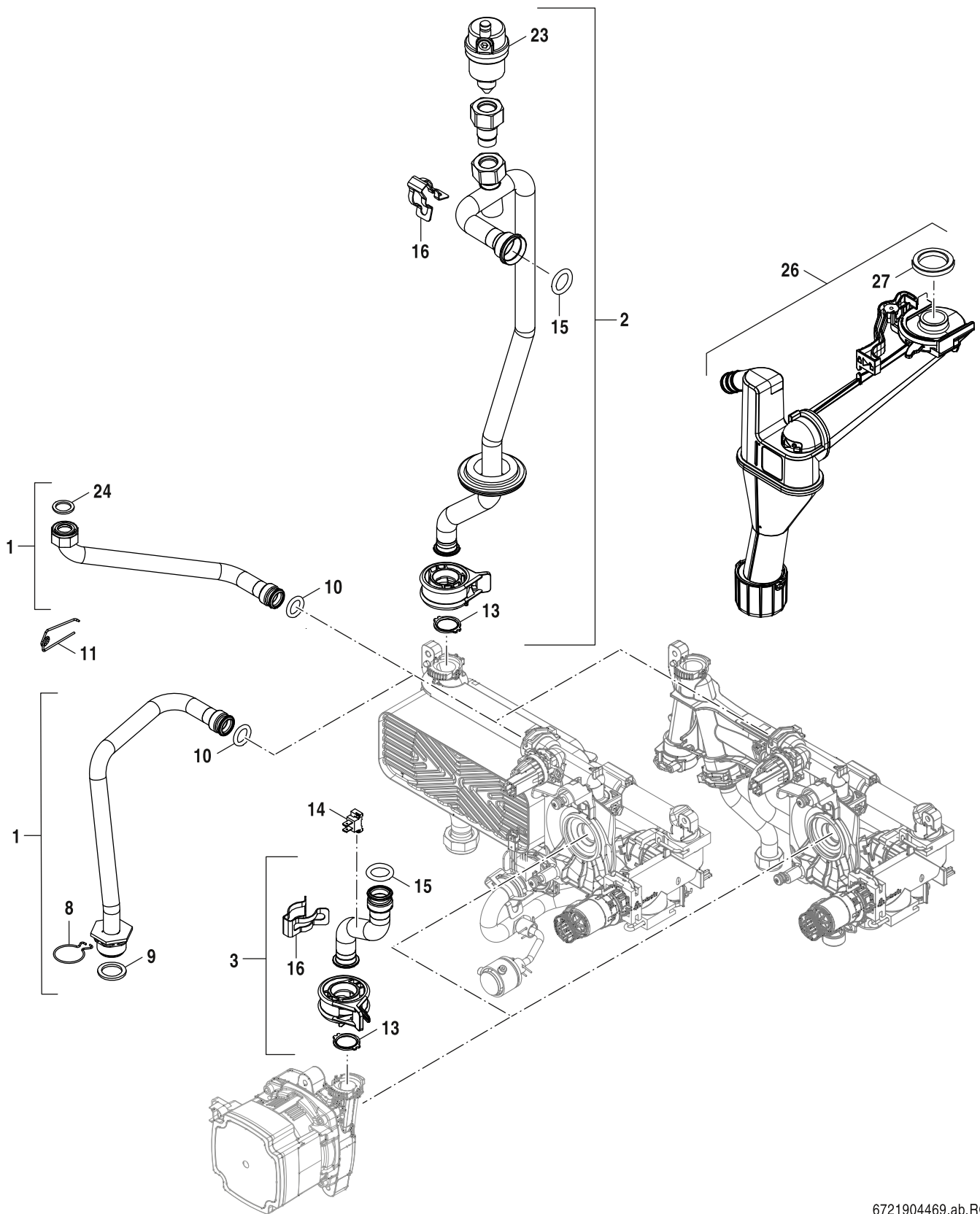

6721904469.ab.RO

Tubes
Rohre

GB172i.2 15-24 W W H

4

Spare parts list
Ersatzteilliste

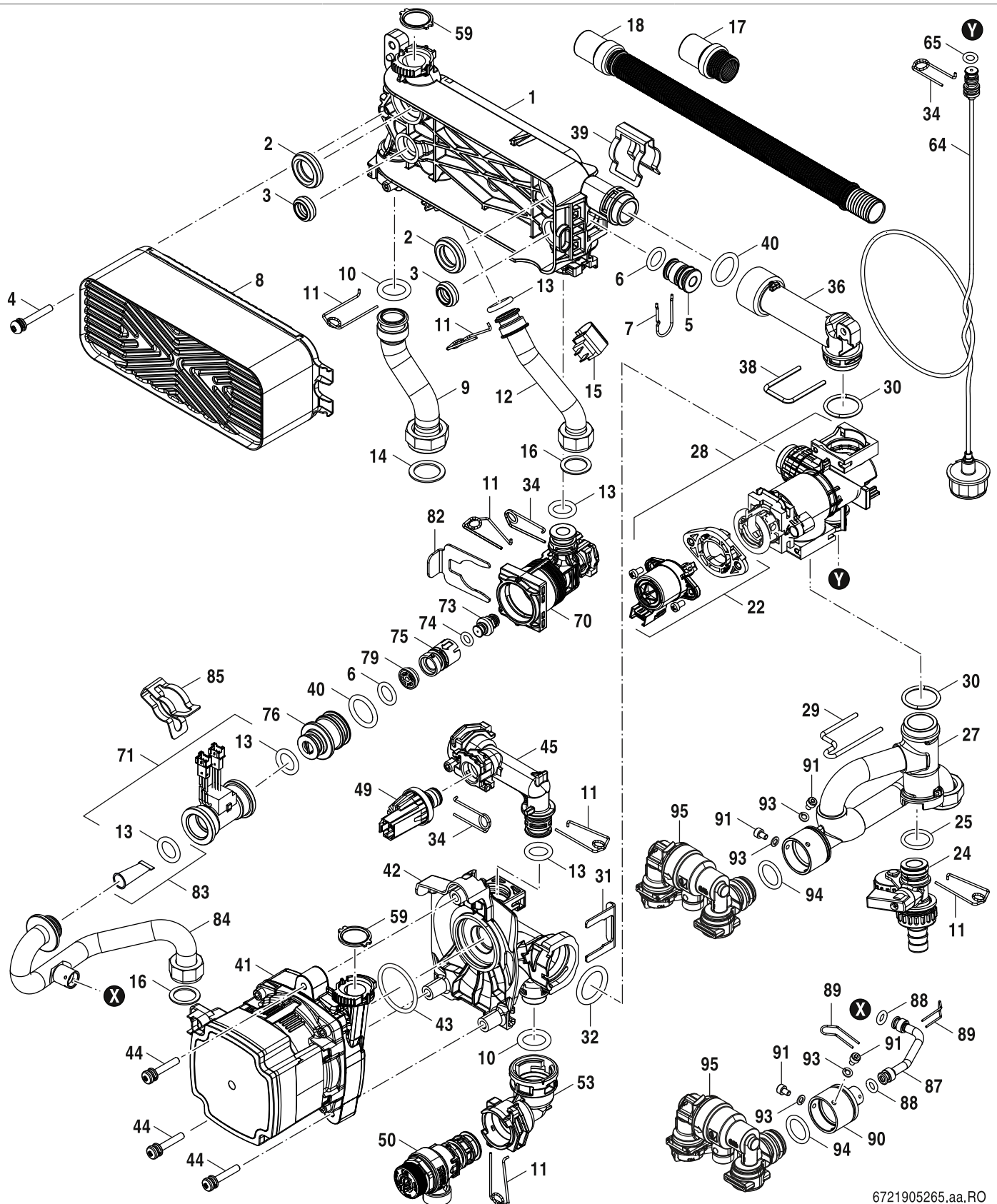

6721905265.aa.RO

Hydraulic block
Hydraulikblock

GB172i.2 15-24 W W H

5A

Pos	Description Bezeichnung	Ordering no. Bestell-Nr.																			Remarks Bemerkungen
			7-736-902-489																		
			7-736-902-490																		
			7-736-902-491																		
1	Manifold plate	8 718 684 471 0	■																		
2	Seal 28,4x8 (10x)	8 716 771 003 0	■																		
3	Seal 19,4x8 (10x)	8 716 771 325 0	■																		
4	Screw M5x35 (10x)	8 718 684 954 0	■																		
5	Plug (5x)	8 718 222 478 0	■																		
6	O-ring 12,5x3 (10x)	8 716 118 019	■																		
7	Clip 13mm	8 716 106 549 0	■																		
8	Plate heat exchanger C-PHE 26	8 718 642 949 0	■																		
9	Supply pipe (CH)	8 737 603 008	■																		
10	O-ring 17x4 (10x)	8 716 771 154 0	■																		
11	Clip 18mm (10x)	8 718 684 699 0	■																		
12	Pipe DHW	8 737 603 009	■																		
13	O-ring 13,87x3,53 (10x)	8 716 771 155 0	■																		
14	Gasket 23,9x17,2x1,5 (10x)	8 710 103 043 0	■																		
15	Temperature sensor NTC	8 716 010 809 0	■																		
16	Gasket 18,6x13,5x1,5 (10x)	8 710 103 045 0	■																		
17	Hose	8 737 712 737	■																		
18	Corrugated pipe	8 737 710 963	■																		
22	Motor (3-way valve)	8 737 602 357	■																		
24	Fill and drain cock	8 737 713 753	■																		
25	O-ring 18,7x2,7 (10x)	8 718 640 414 0	■																		
27	Return pipe (CH)	8 737 603 911	■																		
28	3-way valve	8 737 602 350	■																		
29	Clip (10x)	8 737 602 355	■																		
30	O-ring 23,47x2,62 (10x)	8 737 602 349	■																		
31	Clip (10x)	8 718 681 920 0	■																		
32	O-ring 23x4 (10x)	8 716 771 353 0	■																		
34	Clip 10mm (10x)	8 716 771 167 0	■																		
36	Connecting pipe	8 737 602 348	■																		
38	Clip (10x)	8 737 602 356	■																		
39	Clip (10x)	8 716 113 918 0	■																		
40	O-ring 20,22x3,53 EPDM (10x)	8 718 685 490 0	■																		
41	Pump ErP SpE HU2-10	8 737 602 344	■																		
42	Manifold plate	8 737 602 345	■																		
43	O-ring 34x3 (10x)	8 737 602 346	■																		
44	Screw M5x30 + Washer	8 716 106 452 0	■																		
45	Manifold (Expansion vessel)	8 718 648 973 0	■																		
49	Pressure sensor	8 718 651 042 0	■																		
50	Pressure relief valve	8 718 643 989 0	■																		
53	Connecting pipe (Pressure relief valve)	8 737 602 347	■																		
59	Seal 18,5x24,3 (10x)	8 716 771 259 0	■																		
64	Pressure gauge	8 737 712 661	■																		
65	O-ring 2,62x6,02 WRAS / KTW (10x)	8 716 140 810 0	■																		
70	Adapter (Flow sensor)	8 737 712 177	■																		
71	Flow sensor	8 738 901 168	■																		
73	Pressure relief valve DHW	8 717 401 029 0	■																		
74	O-ring 6,60x2,4 EPDM-70 WRAS / KTW	8 718 617 79A 0	■																		
75	Silencer Body	8 718 617 45A 0	■																		
76	Adapter (Flow limiter)	8 718 644 496 0	■																		
77	O-ring 20,22x3,53 EPDM (10x)	8 718 685 490 0	■																		
79	Flow regulator type E-W 10 l/min	8 716 141 057 0	■																		
82	Clip (10x)	8 716 113 917 0	■																		
GB172i.2 15-24 W W H															Hydraulic block Hydraulikblock					5A	

Spare parts list
Ersatzteilliste

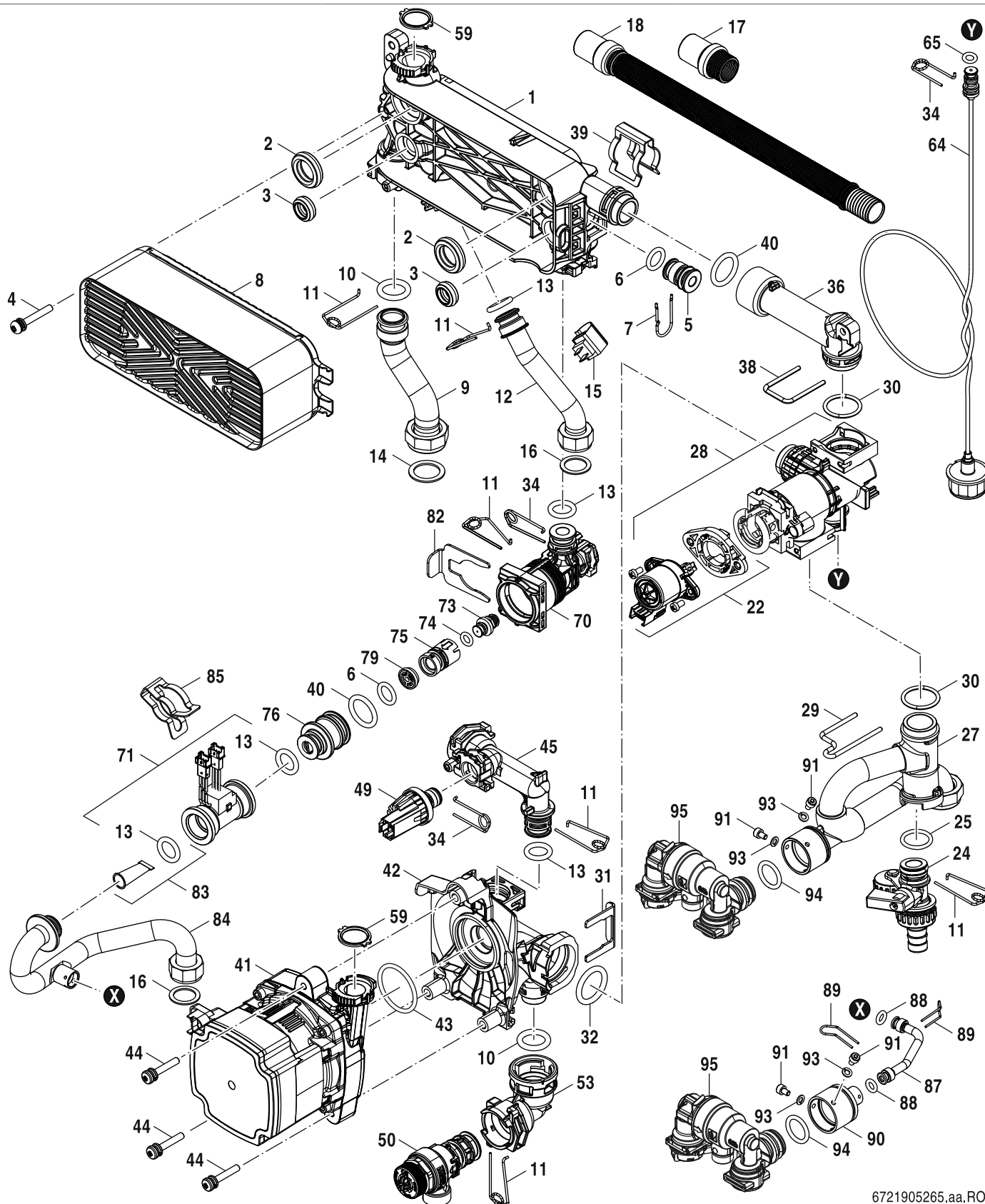

6721905265.aa.RO

Hydraulic block
Hydraulikblock

GB172i.2 15-24 W W H

5A

Pos	Description Bezeichnung	Ordering no. Bestell-Nr.																				Remarks Bemerkungen
				7-736-902-489																		
				7-736-902-490																		
				7-736-902-491																		
83	DHW Filter insert	8 716 106 486 0	■																			
84	Pipe	8 737 603 014	■																			
85	Clip (10x)	8 711 200 024 0	■																			
87	Filling loop	8 737 602 375	■																			
88	O-ring 6x2,5 (10x)	8 718 641 190 0	■																			
89	Wireform Spring (10X)	8 716 148 354 0	■																			
90	Adapter (Flow limiter)	8 737 602 376	■																			
91	Screw socket head cap m4x6mm	2 910 141 116 0	■																			
93	Washer	8 716 121 867	■																			
94	O-ring 17.0 x 3.0 EPDM	8 718 684 044 0	■																			
95	Charging link keyless	8 718 689 275 0	■																			

GB172i.2 15-24 W W H

Hydraulic block
Hydraulikblock

5A

Spare parts list
Ersatzteilliste

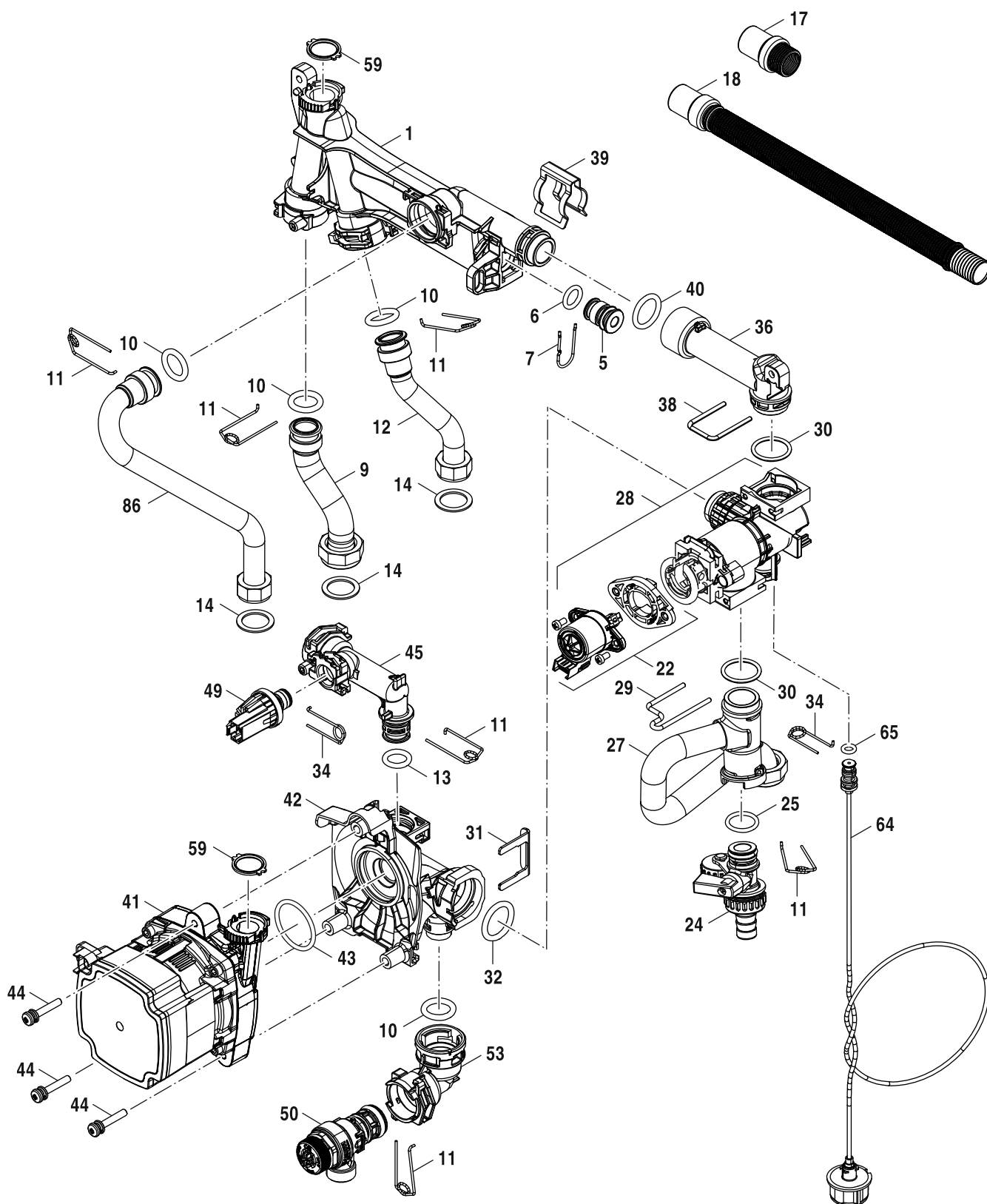

6721904472.aa.RO

Hydraulic block
Hydraulikblock

GB172i.2 15-24 W W H

5B

Pos	Description Bezeichnung	Ordering no. Bestell-Nr.																				Remarks Bemerkungen
			7-736-902-489																			
			7-736-902-490																			
			7-736-902-491																			
1	Manifold	8 718 680 824 0	■	■																		
5	Plug (5x)	8 718 222 478 0	■	■																		
6	O-ring 12,5x3 WRAS / KTW (1x)	8 716 106 748 0	■	■																		
7	Clip 13mm	8 716 106 549 0	■	■																		
9	Supply pipe (CH)	8 737 603 008	■	■																		
10	O-ring 17x4 (10x)	8 716 771 154 0	■	■																		
11	Clip 18mm (10x)	8 718 684 699 0	■	■																		
12	Pipe DHW	8 737 603 011	■	■																		
13	O-ring 13,87x3,53 (10x)	8 716 771 155 0	■	■																		
14	Gasket 23,9x17,2x1,5 (10x)	8 710 103 043 0	■	■																		
17	Hose	8 737 712 737	■	■																		
18	Corrugated pipe	8 737 710 963	■	■																		
22	Motor (3-way valve)	8 737 602 357	■	■																		
24	Fill and drain cock	8 737 713 753	■	■																		
25	O-ring 18,7x2,7 (10x)	8 718 640 414 0	■	■																		
27	Return pipe (CH)	8 737 603 910	■	■																		
28	3-way valve	8 737 602 350	■	■																		
29	Clip (10x)	8 737 602 355	■	■																		
30	O-ring 23,47x2,62 (10x)	8 737 602 349	■	■																		
31	Clip (10x)	8 718 681 920 0	■	■																		
32	O-ring 23x4 (10x)	8 716 771 353 0	■	■																		
34	Clip 10mm (10x)	8 716 771 167 0	■	■																		
36	Connecting pipe	8 737 602 348	■	■																		
38	Clip (10x)	8 737 602 356	■	■																		
39	Clip (10x)	8 716 113 918 0	■	■																		
40	O-ring 20,22x3,53 EPDM (10x)	8 718 685 490 0	■	■																		
41	Pump ErP SpE HU2-10	8 737 602 344	■	■																		
42	Manifold plate	8 737 602 345	■	■																		
43	O-ring 34x3 (10x)	8 737 602 346	■	■																		
44	Screw M5x30 + Washer	8 716 106 452 0	■	■																		
45	Manifold (Expansion vessel)	8 718 648 973 0	■	■																		
49	Pressure sensor	8 718 651 042 0	■	■																		
50	Pressure relief valve	8 718 643 989 0	■	■																		
53	Connecting pipe (Pressure relief valve)	8 737 602 347	■	■																		
59	Seal 18,5x24,3 (10x)	8 716 771 259 0	■	■																		
64	Pressure gauge	8 737 712 661	■	■																		
65	O-ring 2,62x6,02 WRAS / KTW (10x)	8 716 140 810 0	■	■																		
86	Pipe DCW	8 737 603 015	■	■																		

GB172i.2 15-24 W W H

Hydraulic block
Hydraulikblock

5B

Spare parts list
Ersatzteilliste

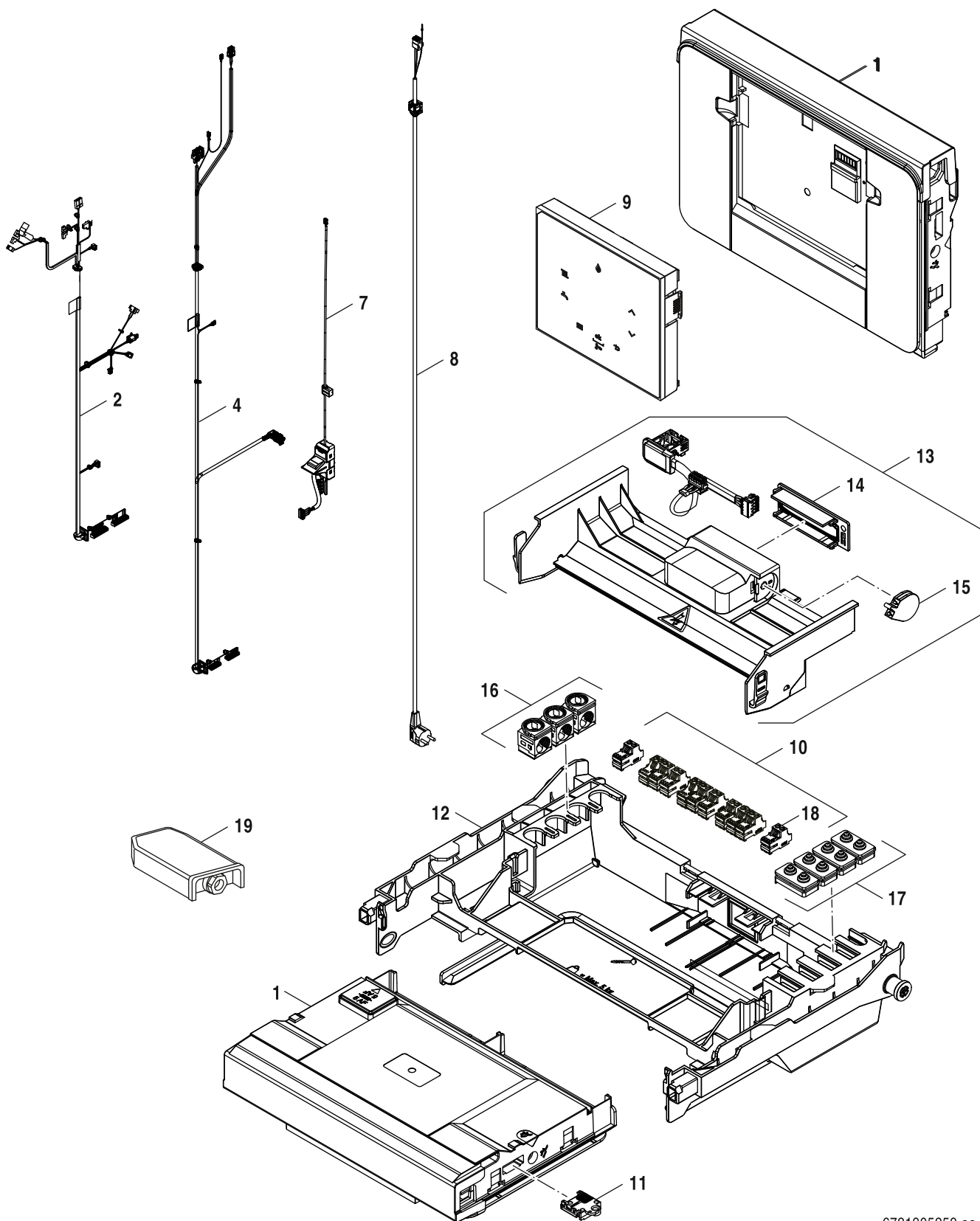

6721905259.aa.RO

Control box
Schaltkasten

GB172i.2 15-24 W W H

6

Pos	Description Bezeichnung	Ordering no. Bestell-Nr.																				Remarks Bemerkungen
				7-736-902-489																		
				7-736-902-490																		
				7-736-902-491																		
1	Control unit ACU MHP-20	8 737 714 735	■	■	■																	
2	Cable harness LV	8 737 603 871	■	■	■																	
4	Cable harness HV	8 737 603 872	■	■	■																	
7	Cable + Switch ON/OFF	8 737 711 282	■	■	■																	
8	Mains cable	8 737 712 655	■	■	■																	
9	Control panel HMI 700	8 737 714 030	■	■	■																	
10	Connector set	8 737 604 210	■	■	■																	
11	Code plug 20492 (NG)	8 737 605 304	■																			
11	Code plug 20501 (NG)	8 737 605 313		■																		
11	Code plug 20503 (NG)	8 737 605 315			■																	
11	Code plug 20573 (LPG)	8 737 605 654	■																			
11	Code plug 20582 (LPG)	8 737 605 663		■																		
11	Code plug 20584 (LPG)	8 737 605 665			■																	
12	Bracket (Control panel)	8 737 604 179	■	■	■																	
13	Cover (Installer access)	8 737 709 196	■	■	■																	
14	Cover (Ip PluX)	8 737 709 148	■	■	■																	
15	Lock (PluX)	8 737 709 149	■	■	■																	
16	Strain relief	8 712 201 007 0	■	■	■																	
17	Grommet feed 2-pole	8 737 704 495 0	■	■	■																	
18	Connector 2-pole (orange brown) RAL8023	8 738 903 694	■	■	■																	
	Gas conversion set LPG-->NG	7 736 902 700	■																			
	Gas conversion set LPG-->NG	7 736 902 709		■																		
	Gas conversion set LPG-->NG	7 736 902 711			■																	
	Gas conversion set NG-->LPG	7 736 902 716	■																			
	Gas conversion set NG-->LPG	7 736 902 725		■																		
	Gas conversion set NG-->LPG	7 736 902 727			■																	

GB172i.2 15-24 W W H

Control box
Schaltkasten

6

List of translations
Übersetzungsliste

Pos	Beschreibung				
1	Baugruppe				
1	Abdeckung Buderus				
2	Seitenteil links				
3	Seitenteil rechts				
4	Blende				
5	Wandhalter				
7	Abdeckung oben				
8	Ausdehnungsgefäß 12L				
9	Halterung (Ausdehnungsgefäß)				
10	Schraube No.10x20 Hex Flansch (3x)				
11	Stopfen				
12	Schnappmutter 4,8mm (10x)				
13	Abgasstutzen				
14	Dichtung Ø80mm				
15	Abgasrohr				
16	Dichtung Ø70mm				
17	Kappe (1x)				
18	Schraube M4x8 (10x)				
19	Schraube M5x15 (10x)				
20	Halterung (Steuereinheit)				
21	Scharnier				
22	Tülle (Kabelführung)				
24	Halterung (Manometer)				
30	Dichtung Gasarmatur 41x3 (10x)				
31	Dichtungs-Set				
33	Halterung (Rohr)				
34	Halterung (Gasrohr)				
35	Schelle				
38	Schraube M4x6 (10x)				
39	Adapter DN80/125				
40	Stopfen				
42	Halterung (Rohr) (rechts)				

List of translations
Übersetzungsliste

Pos	Beschreibung				
43	Halterung (Rohr) (links)				
2	Baugruppe				
1	Wärmetauscher C6-13 (beschichtet)				
2	Elektroden-Set				
3	Dichtung Brenner				
4	Brenner 15 kW				
4	Brenner 30 kW				
5	Verdrängungskörper				
6	Körper unten				
7	Dichtung				
8	Montagegruppe				
9	Abdeckung (Zugang Installateur)				
10	Mutter				
11	Temperaturbegrenzer				
12	Platte				
13	Temperaturbegrenzer				
15	Schraube M5x8 (10x)				
16	Schraube M6x18 (10x)				
17	Halterung				
26	Zündtrafo				
27	Zündkabel				
28	Seal Kondensatwanne				
30	Temperaturfühler NTC				
31	Schraube M5x14 (10x)				
32	Mutter M8 mit Flansch				
33	Dichtung				
34	Tülle				
35	O-Ring 17x4 (10x)				
39	Verdrängungskörper-Set				
	Reinigungsset C6				
	Service-Kit C6-13				
3	Baugruppe				

List of translations
Übersetzungsliste

Pos	Beschreibung				
1	Gebläse				
2	Gasarmatur				
3	Venturi 30 kW G20/G31				
3	Venturi 15 kW G20/G31				
3	Venturi 30 kW G25/GZ35A				
3	Venturi 15 kW G25/GZ35A				
4	Klappenschutz				
5	Rückströmsicherung				
6	Gebläse Kanal				
7	Dichtung (Gebläse)				
8	Dichtung				
9	Schraube M5x15 (3x)				
10	Schraube 4x15 (10x)				
11	Kappe (1x)				
12	Luftansaugrohr				
13	O-Ring NBR 29x2 (10x)				
14	Gasschlauch				
15	Drosselblende 15kW G20/G25				
15	Gasdüse 15 kW G31				
15	Gasdüse 30 kW G31				
15	Gasdüse 30 kW G20 / G25				
16	Mutter				
17	Dichtung Gasarmatur 41x3 (10x)				
18	Gasrohr				
19	Brennerdeckel				
20	Schraube M4x8 (10x)				
21	Steckeranschlussockel 6.3				
23	O-Ring 12x3 (10x)				
4	Baugruppe				
1	Rohr (Ausdehnungsgefäß)				
2	Vorlaufrohr (Wärmetauscher)				
3	Rücklaufrohr				

List of translations
Übersetzungsliste

Pos	Beschreibung				
10	O-Ring 13,87x3,53 (10x)				
11	Haltefeder 18mm (10x)				
13	Dichtung 18,5x24,3 (10x)				
14	Temperaturfühler 18mm				
15	O-Ring 17x4 (10x)				
16	Klammer (10x)				
23	Entlüfter				
24	Dichtung 18,6x11,5x1,5 (10x)				
26	Siphon D03-30				
27	Dichtung				
5A	Baugruppe				
1	Sammler				
2	Dichtung 28,4x8 (10x)				
3	Dichtung 19,4x8 (10x)				
4	Schraube M5x35 (10x)				
5	Stopfen (5x)				
6	O-Ring 12,5x3 (10x)				
7	Haltefeder 13mm				
8	Plattenwärmetauscher C-PHE 26				
9	Vorlaufrohr				
10	O-Ring 17x4 (10x)				
11	Haltefeder 18mm (10x)				
12	Rohr DHW				
13	O-Ring 13,87x3,53 (10x)				
14	Dichtung 23,9x17,2x1,5 (10x)				
15	Temperaturfühler NTC				
16	Dichtung 18,6x13,5x1,5 (10x)				
17	Schlauch Kondensatschlauch				
18	Wellrohr				
22	Antrieb (3-Wege-Ventil)				
24	Füll- und Entleerhahn				
25	O-Ring 18,7x2,7 (10x)				

List of translations
Übersetzungsliste

Pos	Beschreibung				
27	Rücklaufrohr				
28	3-Wege-Ventil				
29	Haltefeder (10x)				
30	O-Ring 23,47x2,62 (10x)				
31	Sicherungsklammer (10x)				
32	O-Ring 23x4 (10x)				
34	Haltefeder 10mm (10x)				
36	Verbindungsrohr				
38	Haltefeder (10x)				
39	Klammer (10x)				
40	O-Ring 20,22x3,53 EPDM (10x)				
41	Pumpe ErP SpE HU2-10				
42	Rohr				
43	O-Ring 34x3 (10x)				
44	Schraube M5x30 + Unterlegscheibe				
45	Anschlussstück (Außdehnungsgefäß)				
49	Druckfühler				
50	Sicherheitsventil				
53	Verbindungsrohr (Sicherheitsventil)				
59	Dichtung 18,5x24,3 (10x)				
64	Manometer				
65	O-Ring 2,62x6,02 WRAS / KTW (10x)				
70	Adapter (Strömungsfühler)				
71	Strömungsfühler				
73	Sicherheitsventil				
74	O-ring 6,60x2,4 EPDM-70 WRAS / KTW				
75	Schalldämpfer Body				
76	Adapter (Durchflussbegrenzer)				
77	O-Ring 20,22x3,53 EPDM (10x)				
79	Durchflussbegrenzer 10 l/min				
82	Sicherungsklammer (10x)				
83	Filter KW				

List of translations
Übersetzungsliste

Pos	Beschreibung				
84	Rohr WW				
85	Klammer (10x)				
87	Fülleinrichtung				
88	O-Ring 6x2,5 (10x)				
89	Haltefeder (10X)				
90	Adapter (Durchflussbegrenzer)				
91	Schraube Innensechskant M4x6mm				
93	Unterlegscheibe				
94	O-Ring (10x)				
95	Fülleinrichtung				
5B	Baugruppe				
1	Sammler				
5	Stopfen (5x)				
6	O-Ring 12,5x3 WRAS / KTW (1x)				
7	Haltefeder 13mm				
9	Vorlaufrohr				
10	O-Ring 17x4 (10x)				
11	Haltefeder 18mm (10x)				
12	Rohr DHW				
13	O-Ring 13,87x3,53 (10x)				
14	Dichtung 23,9x17,2x1,5 (10x)				
17	Schlauch Kondensatschlauch				
18	Wellrohr				
22	Antrieb (3-Wege-Ventil)				
24	Füll- und Entleerhahn				
25	O-Ring 18,7x2,7 (10x)				
27	Rücklaufrohr				
28	3-Wege-Ventil				
29	Haltefeder (10x)				
30	O-Ring 23,47x2,62 (10x)				
31	Sicherungsklammer (10x)				
32	O-Ring 23x4 (10x)				

List of translations
Übersetzungsliste

Pos	Beschreibung				
34	Haltefeder 10mm (10x)				
36	Verbindungsrohr				
38	Haltefeder (10x)				
39	Klammer (10x)				
40	O-Ring 20,22x3,53 EPDM (10x)				
41	Pumpe ErP SpE HU2-10				
42	Rohr				
43	O-Ring 34x3 (10x)				
44	Schraube M5x30 + Unterlegscheibe				
45	Anschlussstück (Außdehnungsgefäß)				
49	Druckfühler				
50	Sicherheitsventil				
53	Verbindungsrohr (Sicherheitsventil)				
59	Dichtung 18,5x24,3 (10x)				
64	Manometer				
65	O-Ring 2,62x6,02 WRAS / KTW (10x)				
86	Rohr DCW				
6	Baugruppe				
1	Steuereinheit ACU MHP-20				
2	Kabelbaum 24V				
4	Kabelbaum 230V				
7	Leitung + Schalter ON/OFF				
8	Netzleitung				
9	Bedienelement HMI 700				
10	Anschlussklemmen-Set				
11	HCM 20492 (NG)				
11	HCM 20501 (NG)				
11	HCM 20503 (NG)				
11	HCM 20573 (LPG)				
11	HCM 20582 (LPG)				
11	HCM 20584 (LPG)				
12	Halterung (Bedienelement)				

List of translations
Übersetzungsliste

Pos	Beschreibung				
13	Abdeckung (Zugang Installateur)				
14	Abdeckung (Ip PluX)				
15	Verriegelung (PluX)				
16	Zugentlastung				
17	Kabeldurchführung 2-polig				
18	Anschlusskl. 2-polig (orangebraun) RAL80				
	Flüssigg.-Umbau LPG-->NG				
	Flüssigg.-Umbau NG-->LPG				

Types of appliances
Gerätetypen

Appliance Gerät	Ordering no. Bestell-Nr.	Country Land	Remarks Bemerkungen
GB172i.2-15 W H	7 736 902 490	Czechia	
GB172i.2-24 KDW H	7 736 902 489	Czechia	
GB172i.2-24 W H	7 736 902 491	Czechia	

Bosch Thermotechnik GmbH
Sophienstr. 30-32
D-35576 Wetzlar / Germany

Buderus